

Massachusetts Department of Environmental Protection  
Bureau of Resource Protection - Wetlands

**WPA Form 3 – Notice of Intent**

Massachusetts Wetlands Protection Act M.G.L. c. 131, §40

Provided by MassDEP:
MassDEP File Number
Document Transaction Number
Boston
City/Town

**Important:**  
When filling out forms on the computer, use only the tab key to move your cursor - do not use the return key.



**Note:**  
Before completing this form consult your local Conservation Commission regarding any municipal bylaw or ordinance.

**A. General Information**

1. Project Location (**Note:** electronic filers will click on button to locate project site):

64-66 Gove St	East Boston	02128
a. Street Address	b. City/Town	c. Zip Code
Latitude and Longitude:	42.371011	-71.036554
ward 1	d. Latitude	e. Longitude
f. Assessors Map/Plat Number	3815	
	g. Parcel /Lot Number	

2. Applicant:

Chan Sing	Ming
a. First Name	b. Last Name
c. Organization	
615 E 7 <sup>th</sup> St	
d. Street Address	
South Boston	MA
e. City/Town	f. State
860-985-0379	02127
h. Phone Number	g. Zip Code
i. Fax Number	j. Email Address

3. Property owner (required if different from applicant):  Check if more than one owner

a. First Name	b. Last Name
c. Organization	
d. Street Address	
e. City/Town	f. State
	g. Zip Code
h. Phone Number	i. Fax Number
	j. Email address

4. Representative (if any):

Kenneth	Bouffard
a. First Name	b. Last Name
Civil Environmental Consultants LLC	
c. Company	
8 Oak St	
d. Street Address	
Peabody	ma
e. City/Town	f. State
978-531-1191	01960
h. Phone Number	g. Zip Code
978-531-5501	ceclandsurvey@comcast.net
i. Fax Number	j. Email address

5. Total WPA Fee Paid (from NOI Wetland Fee Transmittal Form):

1050	512.50	537.50
a. Total Fee Paid	b. State Fee Paid	c. City/Town Fee Paid

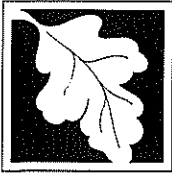

Massachusetts Department of Environmental Protection  
Bureau of Resource Protection - Wetlands

**WPA Form 3 – Notice of Intent**

Massachusetts Wetlands Protection Act M.G.L. c. 131, §40

Provided by MassDEP:
MassDEP File Number
Document Transaction Number
Boston
City/Town

**A. General Information (continued)**

6. General Project Description:

Construction of a 6 Unit Dwelling In a Flood Hazard Zone -AE 10. Site is Approx 1600' from Coastal Bank of Boston Harbor

7a. Project Type Checklist: (Limited Project Types see Section A. 7b.)

- 1.  Single Family Home
- 2.  Residential Subdivision
- 3.  Commercial/Industrial
- 4.  Dock/Pier
- 5.  Utilities
- 6.  Coastal engineering Structure
- 7.  Agriculture (e.g., cranberries, forestry)
- 8.  Transportation
- 9.  Other

7b. Is any portion of the proposed activity eligible to be treated as a limited project (including Ecological Restoration Limited Project) subject to 310 CMR 10.24 (coastal) or 310 CMR 10.53 (inland)?

- 1.  Yes  No If yes, describe which limited project applies to this project. (See 310 CMR 10.24 and 10.53 for a complete list and description of limited project types)

2. Limited Project Type

If the proposed activity is eligible to be treated as an Ecological Restoration Limited Project (310 CMR10.24(8), 310 CMR 10.53(4)), complete and attach Appendix A: Ecological Restoration Limited Project Checklist and Signed Certification.

8. Property recorded at the Registry of Deeds for:

Suffolk

a. County

54973

c. Book

b. Certificate # (if registered land)

158

d. Page Number

**B. Buffer Zone & Resource Area Impacts (temporary & permanent)**

- 1.  Buffer Zone Only – Check if the project is located only in the Buffer Zone of a Bordering Vegetated Wetland, Inland Bank, or Coastal Resource Area.
- 2.  Inland Resource Areas (see 310 CMR 10.54-10.58; if not applicable, go to Section B.3, Coastal Resource Areas).

Check all that apply below. Attach narrative and any supporting documentation describing how the project will meet all performance standards for each of the resource areas altered, including standards requiring consideration of alternative project design or location.

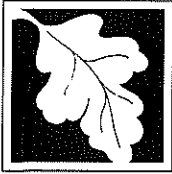

Massachusetts Department of Environmental Protection  
Bureau of Resource Protection - Wetlands

**WPA Form 3 – Notice of Intent**

Massachusetts Wetlands Protection Act M.G.L. c. 131, §40

Provided by MassDEP:

MassDEP File Number

Document Transaction Number

Boston

City/Town

**B. Buffer Zone & Resource Area Impacts (temporary & permanent) (cont'd)**

For all projects affecting other Resource Areas, please attach a narrative explaining how the resource area was delineated.

Resource Area	Size of Proposed Alteration	Proposed Replacement (if any)
a. <input type="checkbox"/> Bank	1. linear feet	2. linear feet
b. <input type="checkbox"/> Bordering Vegetated Wetland	1. square feet	2. square feet
c. <input type="checkbox"/> Land Under Waterbodies and Waterways	1. square feet	2. square feet
	3. cubic yards dredged	

Resource Area	Size of Proposed Alteration	Proposed Replacement (if any)
d. <input type="checkbox"/> Bordering Land Subject to Flooding	1. square feet	2. square feet
	3. cubic feet of flood storage lost	4. cubic feet replaced
e. <input type="checkbox"/> Isolated Land Subject to Flooding	1. square feet	
	2. cubic feet of flood storage lost	3. cubic feet replaced
f. <input type="checkbox"/> Riverfront Area	1. Name of Waterway (if available) - specify coastal or inland	

2. Width of Riverfront Area (check one):

- 25 ft. - Designated Densely Developed Areas only
- 100 ft. - New agricultural projects only
- 200 ft. - All other projects

3. Total area of Riverfront Area on the site of the proposed project: \_\_\_\_\_ square feet

4. Proposed alteration of the Riverfront Area:

- a. total square feet
- b. square feet within 100 ft.
- c. square feet between 100 ft. and 200 ft.

5. Has an alternatives analysis been done and is it attached to this NOI?  Yes  No

6. Was the lot where the activity is proposed created prior to August 1, 1996?  Yes  No

3.  Coastal Resource Areas: (See 310 CMR 10.25-10.35)

**Note:** for coastal riverfront areas, please complete **Section B.2.f.** above.



Massachusetts Department of Environmental Protection  
Bureau of Resource Protection - Wetlands

**WPA Form 3 – Notice of Intent**

Massachusetts Wetlands Protection Act M.G.L. c. 131, §40

Provided by MassDEP:
MassDEP File Number
Document Transaction Number
Boston
City/Town

**B. Buffer Zone & Resource Area Impacts (temporary & permanent) (cont'd)**

Check all that apply below. Attach narrative and supporting documentation describing how the project will meet all performance standards for each of the resource areas altered, including standards requiring consideration of alternative project design or location.

Online Users:  
Include your document transaction number (provided on your receipt page) with all supplementary information you submit to the Department.

Resource Area	Size of Proposed Alteration	Proposed Replacement (if any)
a. <input type="checkbox"/> Designated Port Areas	Indicate size under Land Under the Ocean, below	
b. <input type="checkbox"/> Land Under the Ocean	1. square feet	
	2. cubic yards dredged	
c. <input type="checkbox"/> Barrier Beach	Indicate size under Coastal Beaches and/or Coastal Dunes below	
d. <input type="checkbox"/> Coastal Beaches	1. square feet	2. cubic yards beach nourishment
e. <input type="checkbox"/> Coastal Dunes	1. square feet	2. cubic yards dune nourishment
	Size of Proposed Alteration	Proposed Replacement (if any)
f. <input type="checkbox"/> Coastal Banks	1. linear feet	
g. <input type="checkbox"/> Rocky Intertidal Shores	1. square feet	
h. <input type="checkbox"/> Salt Marshes	1. square feet	2. sq ft restoration, rehab., creation
i. <input type="checkbox"/> Land Under Salt Ponds	1. square feet	
	2. cubic yards dredged	
j. <input type="checkbox"/> Land Containing Shellfish	1. square feet	
k. <input type="checkbox"/> Fish Runs	Indicate size under Coastal Banks, inland Bank, Land Under the Ocean, and/or inland Land Under Waterbodies and Waterways, above	
	1. cubic yards dredged	
	2280	
	1. square feet	
4. <input type="checkbox"/> Restoration/Enhancement	If the project is for the purpose of restoring or enhancing a wetland resource area in addition to the square footage that has been entered in Section B.2.b or B.3.h above, please enter the additional amount here.	
	a. square feet of BWV	b. square feet of Salt Marsh
5. <input type="checkbox"/> Project Involves Stream Crossings		
	a. number of new stream crossings	b. number of replacement stream crossings



Massachusetts Department of Environmental Protection  
Bureau of Resource Protection - Wetlands

**WPA Form 3 – Notice of Intent**

Massachusetts Wetlands Protection Act M.G.L. c. 131, §40

Provided by MassDEP:
MassDEP File Number
Document Transaction Number
Boston
City/Town

**C. Other Applicable Standards and Requirements**

- This is a proposal for an Ecological Restoration Limited Project. Skip Section C and complete Appendix A: Ecological Restoration Limited Project Checklists – Required Actions (310 CMR 10.11).

**Streamlined Massachusetts Endangered Species Act/Wetlands Protection Act Review**

- Is any portion of the proposed project located in **Estimated Habitat of Rare Wildlife** as indicated on the most recent Estimated Habitat Map of State-Listed Rare Wetland Wildlife published by the Natural Heritage and Endangered Species Program (NHESP)? To view habitat maps, see the *Massachusetts Natural Heritage Atlas* or go to [http://maps.massgis.state.ma.us/PRI\\_EST\\_HAB/viewer.htm](http://maps.massgis.state.ma.us/PRI_EST_HAB/viewer.htm).

a.  Yes  No **If yes, include proof of mailing or hand delivery of NOI to:**

Natural Heritage and Endangered Species Program  
Division of Fisheries and Wildlife  
1 Rabbit Hill Road  
Westborough, MA 01581

b. Date of map

If yes, the project is also subject to Massachusetts Endangered Species Act (MESA) review (321 CMR 10.18). To qualify for a streamlined, 30-day, MESA/Wetlands Protection Act review, please complete Section C.1.c, and include requested materials with this Notice of Intent (NOI); OR complete Section C.2.f, if applicable. *If MESA supplemental information is not included with the NOI, by completing Section 1 of this form, the NHESP will require a separate MESA filing which may take up to 90 days to review (unless noted exceptions in Section 2 apply, see below).*

c. Submit Supplemental Information for Endangered Species Review\*

- Percentage/acreage of property to be altered:

(a) within wetland Resource Area \_\_\_\_\_  
percentage/acreage

(b) outside Resource Area \_\_\_\_\_  
percentage/acreage

- Assessor's Map or right-of-way plan of site

- Project plans for entire project site, including wetland resource areas and areas outside of wetlands jurisdiction, showing existing and proposed conditions, existing and proposed tree/vegetation clearing line, and clearly demarcated limits of work \*\*

(a)  Project description (including description of impacts outside of wetland resource area & buffer zone)

Some projects **not** in Estimated Habitat may be located in Priority Habitat, and require NHESP review (see <http://www.mass.gov/eea/agencies/dfg/dfw/natural-heritage/regulatory-review/>). Priority Habitat includes habitat for state-listed plants and strictly upland species not protected by the Wetlands Protection Act.

\*\* MESA projects may not be segmented (321 CMR 10.16). The applicant must disclose full development plans even if such plans are not required as part of the Notice of Intent process.



Massachusetts Department of Environmental Protection  
Bureau of Resource Protection - Wetlands

**WPA Form 3 – Notice of Intent**

Massachusetts Wetlands Protection Act M.G.L. c. 131, §40

Provided by MassDEP:
MassDEP File Number
Document Transaction Number
Boston
City/Town

(b)  Photographs representative of the site

**C. Other Applicable Standards and Requirements (cont'd)**

(c)  MESA filing fee (fee information available at [http://www.mass.gov/dfwele/dfw/nhosp/regulatory\\_review/ mesa/ mesa\\_fee\\_schedule.htm](http://www.mass.gov/dfwele/dfw/nhosp/regulatory_review/ mesa/ mesa_fee_schedule.htm)). Make check payable to "Commonwealth of Massachusetts - NHESP" and **mail to NHESP** at above address

*Projects altering 10 or more acres of land, also submit:*

(d)  Vegetation cover type map of site

(e)  Project plans showing Priority & Estimated Habitat boundaries

(f) OR Check One of the Following

1.  Project is exempt from MESA review. Attach applicant letter indicating which MESA exemption applies. (See 321 CMR 10.14, [http://www.mass.gov/dfwele/dfw/nhosp/regulatory\\_review/ mesa/ mesa\\_exemptions.htm](http://www.mass.gov/dfwele/dfw/nhosp/regulatory_review/ mesa/ mesa_exemptions.htm); the NOI must still be sent to NHESP if the project is within estimated habitat pursuant to 310 CMR 10.37 and 10.59.)

2.  Separate MESA review ongoing. a. NHESP Tracking # \_\_\_\_\_ b. Date submitted to NHESP \_\_\_\_\_

3.  Separate MESA review completed. Include copy of NHESP "no Take" determination or valid Conservation & Management Permit with approved plan.

3. For coastal projects only, is any portion of the proposed project located below the mean high water line or in a fish run?

a.  Not applicable – project is in inland resource area only      b.  Yes     No

If yes, include proof of mailing, hand delivery, or electronic delivery of NOI to either:

South Shore - Cohasset to Rhode Island border, and the Cape & Islands:

Division of Marine Fisheries -  
Southeast Marine Fisheries Station  
Attn: Environmental Reviewer  
836 South Rodney French Blvd.  
New Bedford, MA 02744  
Email: [DMF.EnvReview-South@state.ma.us](mailto:DMF.EnvReview-South@state.ma.us)

North Shore - Hull to New Hampshire border:

Division of Marine Fisheries -  
North Shore Office  
Attn: Environmental Reviewer  
30 Emerson Avenue  
Gloucester, MA 01930  
Email: [DMF.EnvReview-North@state.ma.us](mailto:DMF.EnvReview-North@state.ma.us)

Also if yes, the project may require a Chapter 91 license. For coastal towns in the Northeast Region, please contact MassDEP's Boston Office. For coastal towns in the Southeast Region, please contact MassDEP's Southeast Regional Office.

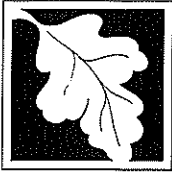

Massachusetts Department of Environmental Protection  
Bureau of Resource Protection - Wetlands

**WPA Form 3 – Notice of Intent**

Massachusetts Wetlands Protection Act M.G.L. c. 131, §40

Provided by MassDEP:

MassDEP File Number

Document Transaction Number

Boston

City/Town

**C. Other Applicable Standards and Requirements (cont'd)**

**Online Users:**  
Include your document transaction number (provided on your receipt page) with all supplementary information you submit to the Department.

4. Is any portion of the proposed project within an Area of Critical Environmental Concern (ACEC)?
- a.  Yes  No If yes, provide name of ACEC (see instructions to WPA Form 3 or MassDEP Website for ACEC locations). **Note:** electronic filers click on Website.
- b. ACEC
5. Is any portion of the proposed project within an area designated as an Outstanding Resource Water (ORW) as designated in the Massachusetts Surface Water Quality Standards, 314 CMR 4.00?
- a.  Yes  No
6. Is any portion of the site subject to a Wetlands Restriction Order under the Inland Wetlands Restriction Act (M.G.L. c. 131, § 40A) or the Coastal Wetlands Restriction Act (M.G.L. c. 130, § 105)?
- a.  Yes  No
7. Is this project subject to provisions of the MassDEP Stormwater Management Standards?
- a.  Yes. Attach a copy of the Stormwater Report as required by the Stormwater Management Standards per 310 CMR 10.05(6)(k)-(q) and check if:
1.  Applying for Low Impact Development (LID) site design credits (as described in Stormwater Management Handbook Vol. 2, Chapter 3)
  2.  A portion of the site constitutes redevelopment
  3.  Proprietary BMPs are included in the Stormwater Management System.
- b.  No. Check why the project is exempt:
1.  Single-family house
  2.  Emergency road repair
  3.  Small Residential Subdivision (less than or equal to 4 single-family houses or less than equal to 4 units in multi-family housing project) with no discharge to Critical Areas.

**D. Additional Information**

- This is a proposal for an Ecological Restoration Limited Project. Skip Section D and complete Appendix A: Ecological Restoration Notice of Intent – Minimum Required Documents (310 CMR 10.12).

Applicants must include the following with this Notice of Intent (NOI). See instructions for details.

**Online Users:** Attach the document transaction number (provided on your receipt page) for any of the following information you submit to the Department.

1.  USGS or other map of the area (along with a narrative description, if necessary) containing sufficient information for the Conservation Commission and the Department to locate the site. (Electronic filers may omit this item.)

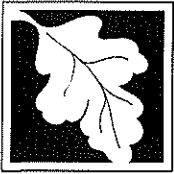

Massachusetts Department of Environmental Protection  
Bureau of Resource Protection - Wetlands

**WPA Form 3 – Notice of Intent**

Massachusetts Wetlands Protection Act M.G.L. c. 131, §40

Provided by MassDEP:
MassDEP File Number
Document Transaction Number
Boston
City/Town

- Plans identifying the location of proposed activities (including activities proposed to serve as

**D. Additional Information (cont'd)**

- Identify the method for BVW and other resource area boundary delineations (MassDEP BVW Field Data Form(s), Determination of Applicability, Order of Resource Area Delineation, etc.), and attach documentation of the methodology.

- List the titles and dates for all plans and other materials submitted with this NOI.

Conservation Plan

a. Plan Title	Civil Environmental Consultants LLC	Frederick J. Geisel
b. Prepared By	2/26/18	c. Signed and Stamped by 1"=10'
d. Final Revision Date	Site Plan #15-446	e. Scale
f. Additional Plan or Document Title		g. Date 11/30/15

- If there is more than one property owner, please attach a list of these property owners not listed on this form.
- Attach proof of mailing for Natural Heritage and Endangered Species Program, if needed.
- Attach proof of mailing for Massachusetts Division of Marine Fisheries, if needed.
- Attach NOI Wetland Fee Transmittal Form
- Attach Stormwater Report, if needed.

**E. Fees**

- Fee Exempt: No filing fee shall be assessed for projects of any city, town, county, or district of the Commonwealth, federally recognized Indian tribe housing authority, municipal housing authority, or the Massachusetts Bay Transportation Authority.

Applicants must submit the following information (in addition to pages 1 and 2 of the NOI Wetland Fee Transmittal Form) to confirm fee payment:

31313	2/20/18
2. Municipal Check Number	3. Check date
31312	2/220/18
4. State Check Number	5. Check date
Carol	Bouffard
6. Payor name on check: First Name	7. Payor name on check: Last Name



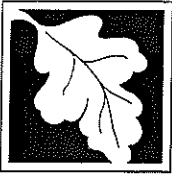

Massachusetts Department of Environmental Protection  
Bureau of Resource Protection - Wetlands

# WPA Form 3 – Notice of Intent

Massachusetts Wetlands Protection Act M.G.L. c. 131, §40

Provided by MassDEP:
MassDEP File Number
Document Transaction Number
Boston
City/Town

## F. Signatures and Submittal Requirements

I hereby certify under the penalties of perjury that the foregoing Notice of Intent and accompanying plans, documents, and supporting data are true and complete to the best of my knowledge. I understand that the Conservation Commission will place notification of this Notice in a local newspaper at the expense of the applicant in accordance with the wetlands regulations, 310 CMR 10.05(5)(a).

I further certify under penalties of perjury that all abutters were notified of this application, pursuant to the requirements of M.G.L. c. 131, § 40. Notice must be made by Certificate of Mailing or in writing by hand delivery or certified mail (return receipt requested) to all abutters within 100 feet of the property line of the project location.

1. Signature of Applicant <i>* [Signature]</i>	2. Date 2/9/18
3. Signature of Property Owner (if different) <i>[Signature]</i>	4. Date 2/9/18
5. Signature of Representative (if any) <i>[Signature]</i>	6. Date

### For Conservation Commission:

Two copies of the completed Notice of Intent (Form 3), including supporting plans and documents, two copies of the NOI Wetland Fee Transmittal Form, and the city/town fee payment, to the Conservation Commission by certified mail or hand delivery.

### For MassDEP:

One copy of the completed Notice of Intent (Form 3), including supporting plans and documents, one copy of the NOI Wetland Fee Transmittal Form, and a **copy** of the state fee payment to the MassDEP Regional Office (see Instructions) by certified mail or hand delivery.

### Other:

If the applicant has checked the "yes" box in any part of Section C, Item 3, above, refer to that section and the Instructions for additional submittal requirements.

The original and copies must be sent simultaneously. Failure by the applicant to send copies in a timely manner may result in dismissal of the Notice of Intent.

## **NARRATIVE – FEB 25, 2018**

### **64/66 GOVE STREET, E. BOSTON, MA**

#### **Background:**

The property is located at 64-66 Gove Street in E. Boston, MA. This is a redevelopment site. The total area of property to be redeveloped consists of 2280 sq. ft. of land. The site was previously two separate lots, each containing a multi-family house. The two houses together occupied 1937 sq. ft. of the site. The project proponent proposes to construct a six unit dwelling in a single structure. The project is a full redevelopment of the site.

#### **Soil Conditions**

The soils are classified as Udorthents -sandy and Urban land. Two test borings were conducted. The soils are classified as Class B soils, for drainage purposes.

#### **Flood Plain**

The project site is within the Special Flood Hazard Areas designated by FEMA, for the 100-yr storm, with a flood elevation of AE-10.

#### **Wetlands**

There are no wetland resource areas within 500 feet of the site.

#### **Stormwater Management**

As a redevelopment site, the project is required to meet Stormwater Standards to the maximum Extent Practicable. Roof runoff is infiltrated by two Stormtech SC-740 Infiltrators, which hold and infiltrate a 1-inch storm. Based on our analysis and design, the post-development flow rates and volume will be reduced from the pre-development flows for the analyzed frequency storms – 2-yr, 10-yr and 25-yr. Flooding will not be increased for the 100-yr storm. All storm events will be infiltrated by the roof infiltrator systems. All Stormwater Management Standards will be met for the site.

All peak flows from the proposed roof areas will be attenuated by storage and infiltration through infiltration chambers that will store and infiltrate stormwater. These chambers will be as shown on the proposed site plan with the galleries for the building located in adjacent lawn/landscape areas.

Land in the rear will be landscaped with loam and grass, mulch, shrubs, and trees that will all serve to improve the soil conditions to adsorb more rainfall and reduce runoff.

Frederick J. Geisel, PE

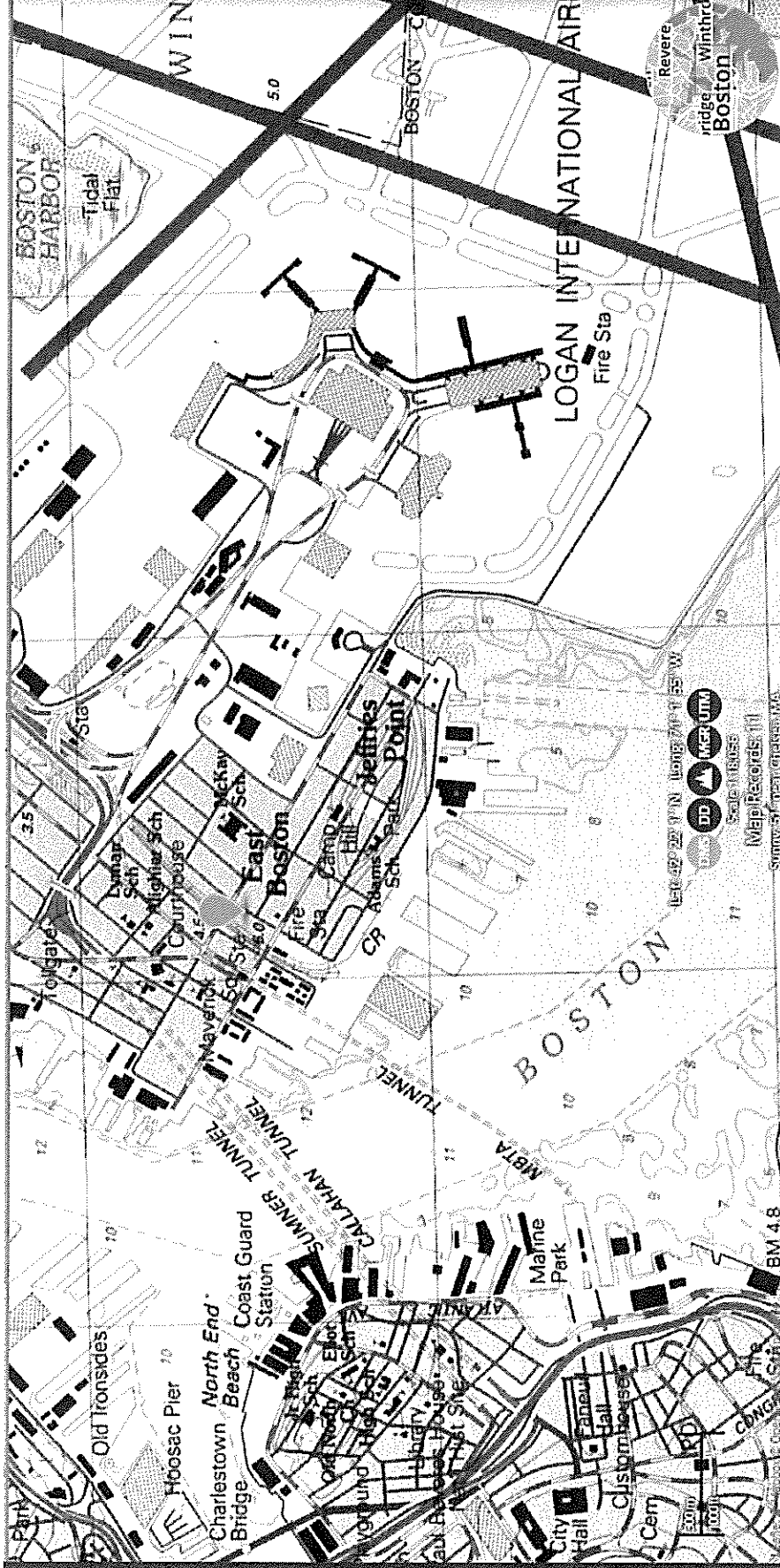

- Boston South, MA 1970 (1973 ed.)
- JREG (4.MB)
- KMZ (3.MB)
- SHOW KEY
- Boston South, MA 1970 (1979 ed.)
- Boston South, MA 1977 (1980 ed.)
- Boston South, MA 1987 (1987 ed.)
- Boston South, MA 1987 (1987 ed.)

42° 22' 41" N 71° 05' 55" W  
Scale: 1:18,555  
MapRecords: 11  
Sunny: 57 near Grasses, MA

Reverse  
Winthra  
ridges  
Boston

CIVIL ENVIRONMENTAL CONSULTANTS LLC  
ENGINEERS AND LAND SURVEYORS

---

8 Oak Street  
Peabody, MA 01960  
Phone (978) 531-1191  
Fax (978) 531-5501  
ceclandsurvey@comcast.net

June 6, 2018

Boston Conservation Commission

RE: 64-66 Gove Street East Boston, MA Project Narrative

The Locus address lies within the Fema ae 10 zone, and lies approximately 1,700 feet from the nearest resource area.

The Proposed Work at the above referenced address is to construct a 40x44'6" 3 story 6 unit dwelling with a basement on a parcel that contains 2280 square feet.

To mitigate any potential impacts to the adjacent areas, straw wattle will be staked in place around the site perimeter to inhibit any impacts off site. The site is fairly flat and any erosion caused by weather events, will be impeded and contained on site by the placement of the straw wattle at the perimeter. Stormwater will be hindered by the straw wattle from flowing offsite during construction. Also during construction the catch basin in norwood street adjacent to the property will have a silt sack installed to prevent soil erosion into the city drainage system, also, straw wattle will be placed around the catch basin to further prevent infiltration of material to the city drainage system.

Post construction,

A stormwater infiltration basin will have been installed, sized in accordance to the City of Boston Water and Sewer Commission requirements.

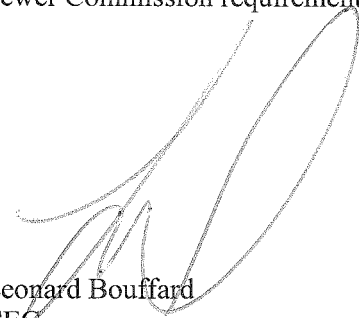

Leonard Bouffard  
CEC

# National Flood Hazard Layer FIRMMette



42°22'29.01"N

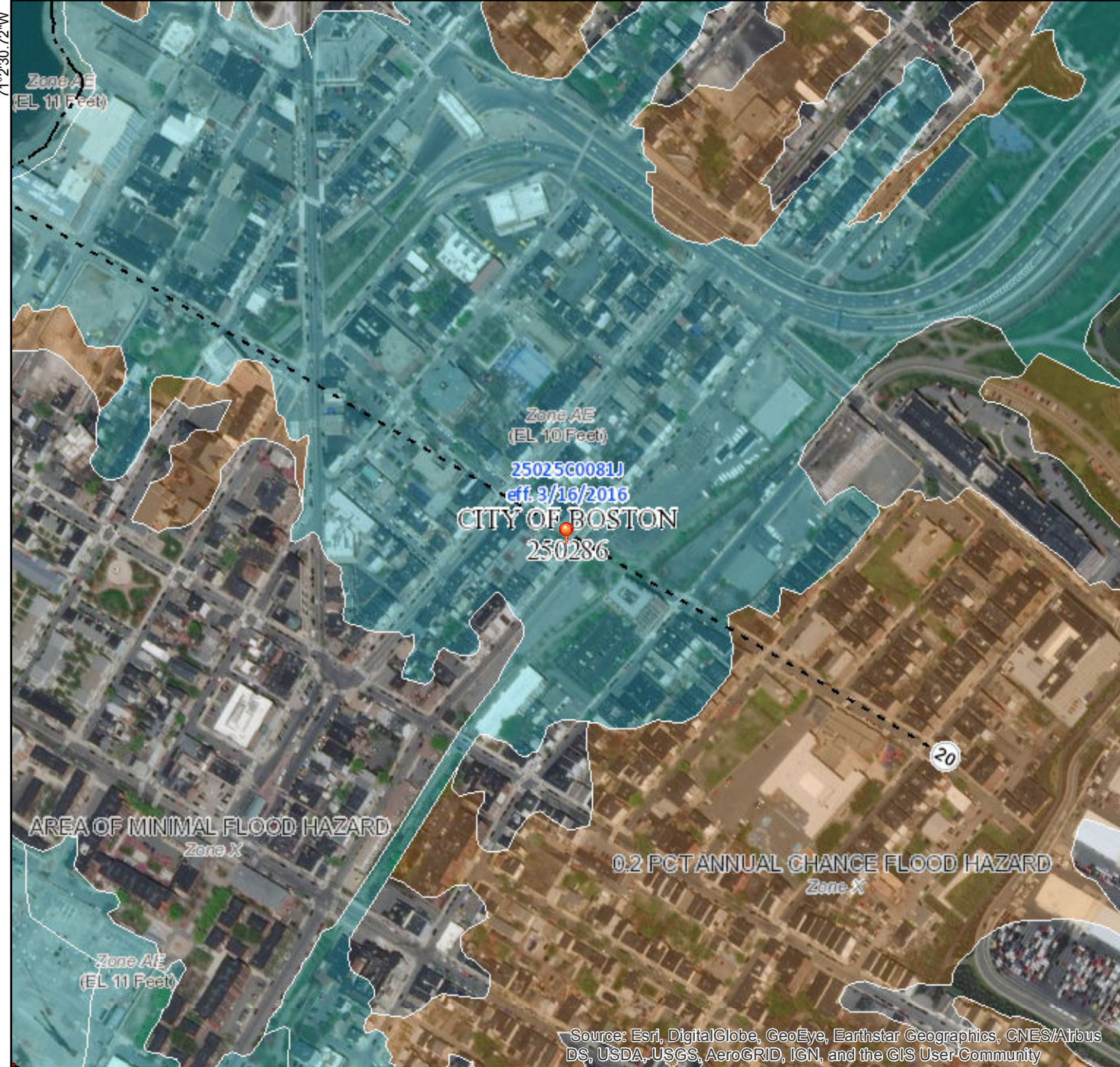

0 250 500 1,000 1,500 2,000 Feet 1:6,000 42°22'2.43"N

## Legend

SEE FIS REPORT FOR DETAILED LEGEND AND INDEX MAP FOR FIRM PANEL LAYOUT

SPECIAL FLOOD HAZARD AREAS		Without Base Flood Elevation (BFE) Zone A, V, A99
		With BFE or Depth
		Regulatory Floodway Zone AE, AO, AH, VE, AR
OTHER AREAS OF FLOOD HAZARD		0.2% Annual Chance Flood Hazard, Areas of 1% annual chance flood with average depth less than one foot or with drainage areas of less than one square mile Zone X
		Future Conditions 1% Annual Chance Flood Hazard Zone X
		Area with Reduced Flood Risk due to Levee. See Notes. Zone X
		Area with Flood Risk due to Levee Zone D
OTHER AREAS		Area of Minimal Flood Hazard Zone X
		Effective LOMRs
		Area of Undetermined Flood Hazard Zone D
GENERAL STRUCTURES		Channel, Culvert, or Storm Sewer
		Levee, Dike, or Floodwall
OTHER FEATURES		Cross Sections with 1% Annual Chance Water Surface Elevation
		Coastal Transect
		Base Flood Elevation Line (BFE)
		Limit of Study
		Jurisdiction Boundary
		Coastal Transect Baseline
MAP PANELS		Digital Data Available
		No Digital Data Available
		Unmapped

This map complies with FEMA's standards for the use of digital flood maps if it is not void as described below. The base map shown complies with FEMA's base map accuracy standards

The flood hazard information is derived directly from the authoritative NFHL web services provided by FEMA. This map was exported on 6/6/2018 at 9:30:07 AM and does not reflect changes or amendments subsequent to this date and time. The NFHL and effective information may change or become superseded by new data over time.

This map image is void if the one or more of the following map elements do not appear: base map imagery, flood zone labels, legend, scale bar, map creation date, community identifiers, FIRM panel number, and FIRM effective date. Map images for unmapped and unmodernized areas cannot be used for regulatory purposes.

71°15'32.27"W

Source: Esri, DigitalGlobe, GeoEye, Earthstar Geographics, CNES/Airbus DS, USDA, USGS, AeroGRID, IGN, and the GIS User Community

# **STORMWATER MANAGEMENT REPORT**

**FOR**

**64-66 GOVE STREET**

**IN**

**E. BOSTON , MASS**

**BY**

**CIVIL ENVIRONMENTAL CONSULTANTS**

**FEBRUARY 27, 2018**

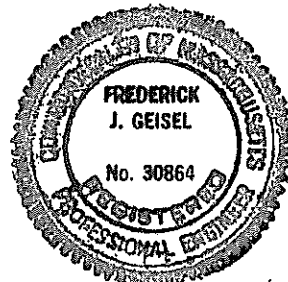

**FREDERICK J. GEISEL, PE**

## **STORMWATER MANAGEMENT REPORT – FEB 25, 2018**

### **64/66 GOVE STREET, E. BOSTON, MA**

#### **Background:**

The property is located at 64-66 Gove Street in E. Boston, MA. This is a redevelopment site. The total area of property to be redeveloped consists of 2280 sq. ft. of land. The site was previously two separate lots, each containing a multi-family house. The two houses together occupied 1937 sq. ft. of the site. The project proponent proposes to construct a six unit dwelling in a single structure. The project is a full redevelopment of the site.

#### **Soil Conditions**

The soils are classified as Udorthents -sandy and Urban land. Two test borings were conducted. The soils are classified as Class B soils, for drainage purposes.

#### **Flood Plain**

The project site is within the Special Flood Hazard Areas designated by FEMA, for the 100-yr storm, with a flood elevation of AE-10.

#### **Wetlands**

There are no wetland resource areas within 500 feet of the site.

#### **Stormwater Management**

As a redevelopment site, the project is required to meet Stormwater Standards to the maximum Extent Practicable. Roof runoff is infiltrated by two Stormtech SC-740 Infiltrators, which hold and infiltrate a 1-inch storm. Based on our analysis and design, the post-development flow rates and volume will be reduced from the pre-development flows for the analyzed frequency storms – 2-yr, 10-yr and 25-yr. Flooding will not be increased for the 100-yr storm. All storm events will be infiltrated by the roof infiltrator systems. All Stormwater Management Standards will be met for the site.

All peak flows from the proposed roof areas will be attenuated by storage and infiltration through infiltration chambers that will store and infiltrate stormwater. These chambers will be as shown on the proposed site plan with the galleries for the building located in adjacent lawn/landscape areas.

Land in the rear will be landscaped with loam and grass, mulch, shrubs, and trees that will all serve to improve the soil conditions to adsorb more rainfall and reduce runoff.



# Checklist for Stormwater Report

## A. Introduction

**Important:** When filling out forms on the computer, use only the tab key to move your cursor - do not use the return key.



A Stormwater Report must be submitted with the Notice of Intent permit application to document compliance with the Stormwater Management Standards. The following checklist is NOT a substitute for the Stormwater Report (which should provide more substantive and detailed information) but is offered here as a tool to help the applicant organize their Stormwater Management documentation for their Report and for the reviewer to assess this information in a consistent format. As noted in the Checklist, the Stormwater Report must contain the engineering computations and supporting information set forth in Volume 3 of the [Massachusetts Stormwater Handbook](#). The Stormwater Report must be prepared and certified by a Registered Professional Engineer (RPE) licensed in the Commonwealth.

The Stormwater Report must include:

- The Stormwater Checklist completed and stamped by a Registered Professional Engineer (see page 2) that certifies that the Stormwater Report contains all required submittals.<sup>1</sup> This Checklist is to be used as the cover for the completed Stormwater Report.
- Applicant/Project Name
- Project Address
- Name of Firm and Registered Professional Engineer that prepared the Report
- Long-Term Pollution Prevention Plan required by Standards 4-6
- Construction Period Pollution Prevention and Erosion and Sedimentation Control Plan required by Standard 8<sup>2</sup>
- Operation and Maintenance Plan required by Standard 9

In addition to all plans and supporting information, the Stormwater Report must include a brief narrative describing stormwater management practices, including environmentally sensitive site design and LID techniques, along with a diagram depicting runoff through the proposed BMP treatment train. Plans are required to show existing and proposed conditions, identify all wetland resource areas, NRCS soil types, critical areas, Land Uses with Higher Potential Pollutant Loads (LUHPPL), and any areas on the site where infiltration rate is greater than 2.4 inches per hour. The Plans shall identify the drainage areas for both existing and proposed conditions at a scale that enables verification of supporting calculations.

As noted in the Checklist, the Stormwater Management Report shall document compliance with each of the Stormwater Management Standards as provided in the Massachusetts Stormwater Handbook. The soils evaluation and calculations shall be done using the methodologies set forth in Volume 3 of the Massachusetts Stormwater Handbook.

To ensure that the Stormwater Report is complete, applicants are required to fill in the Stormwater Report Checklist by checking the box to indicate that the specified information has been included in the Stormwater Report. If any of the information specified in the checklist has not been submitted, the applicant must provide an explanation. The completed Stormwater Report Checklist and Certification must be submitted with the Stormwater Report.

<sup>1</sup> The Stormwater Report may also include the Illicit Discharge Compliance Statement required by Standard 10. If not included in the Stormwater Report, the Illicit Discharge Compliance Statement must be submitted prior to the discharge of stormwater runoff to the post-construction best management practices.

<sup>2</sup> For some complex projects, it may not be possible to include the Construction Period Erosion and Sedimentation Control Plan in the Stormwater Report. In that event, the issuing authority has the discretion to issue an Order of Conditions that approves the project and includes a condition requiring the proponent to submit the Construction Period Erosion and Sedimentation Control Plan before commencing any land disturbance activity on the site.





# Checklist for Stormwater Report

## B. Stormwater Checklist and Certification

The following checklist is intended to serve as a guide for applicants as to the elements that ordinarily need to be addressed in a complete Stormwater Report. The checklist is also intended to provide conservation commissions and other reviewing authorities with a summary of the components necessary for a comprehensive Stormwater Report that addresses the ten Stormwater Standards.

*Note:* Because stormwater requirements vary from project to project, it is possible that a complete Stormwater Report may not include information on some of the subjects specified in the Checklist. If it is determined that a specific item does not apply to the project under review, please note that the item is not applicable (N.A.) and provide the reasons for that determination.

A complete checklist must include the Certification set forth below signed by the Registered Professional Engineer who prepared the Stormwater Report.

### Registered Professional Engineer's Certification

I have reviewed the Stormwater Report, including the soil evaluation, computations, Long-term Pollution Prevention Plan, the Construction Period Erosion and Sedimentation Control Plan (if included), the Long-term Post-Construction Operation and Maintenance Plan, the Illicit Discharge Compliance Statement (if included) and the plans showing the stormwater management system, and have determined that they have been prepared in accordance with the requirements of the Stormwater Management Standards as further elaborated by the Massachusetts Stormwater Handbook. I have also determined that the information presented in the Stormwater Checklist is accurate and that the information presented in the Stormwater Report accurately reflects conditions at the site as of the date of this permit application.

Registered Professional Engineer Block and Signature

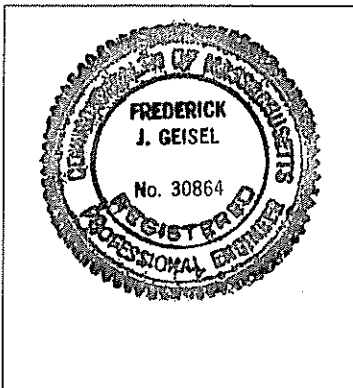

*[Handwritten Signature]* 7/27/18  
Signature and Date

### Checklist

**Project Type:** Is the application for new development, redevelopment, or a mix of new and redevelopment?

- New development
- Redevelopment
- Mix of New Development and Redevelopment



# Checklist for Stormwater Report

---

## Checklist (continued)

**LID Measures:** Stormwater Standards require LID measures to be considered. Document what environmentally sensitive design and LID Techniques were considered during the planning and design of the project:

- No disturbance to any Wetland Resource Areas
- Site Design Practices (e.g. clustered development, reduced frontage setbacks)
- Reduced Impervious Area (Redevelopment Only)
- Minimizing disturbance to existing trees and shrubs
- LID Site Design Credit Requested:
  - Credit 1
  - Credit 2
  - Credit 3
- Use of "country drainage" versus curb and gutter conveyance and pipe
- Bioretention Cells (includes Rain Gardens)
- Constructed Stormwater Wetlands (includes Gravel Wetlands designs)
- Treebox Filter
- Water Quality Swale
- Grass Channel
- Green Roof
- Other (describe): \_\_\_\_\_

### Standard 1: No New Untreated Discharges

- No new untreated discharges
- Outlets have been designed so there is no erosion or scour to wetlands and waters of the Commonwealth
- Supporting calculations specified in Volume 3 of the Massachusetts Stormwater Handbook included.



# Checklist for Stormwater Report

## Checklist (continued)

### Standard 2: Peak Rate Attenuation

- Standard 2 waiver requested because the project is located in land subject to coastal storm flowage and stormwater discharge is to a wetland subject to coastal flooding.
- Evaluation provided to determine whether off-site flooding increases during the 100-year 24-hour storm.
- Calculations provided to show that post-development peak discharge rates do not exceed pre-development rates for the 2-year and 10-year 24-hour storms. If evaluation shows that off-site flooding increases during the 100-year 24-hour storm, calculations are also provided to show that post-development peak discharge rates do not exceed pre-development rates for the 100-year 24-hour storm.

### Standard 3: Recharge

- Soil Analysis provided.
- Required Recharge Volume calculation provided.
- Required Recharge volume reduced through use of the LID site Design Credits.
- Sizing the infiltration, BMPs is based on the following method: Check the method used.
  - Static
  - Simple Dynamic
  - Dynamic Field<sup>1</sup>
- Runoff from all impervious areas at the site discharging to the infiltration BMP.
- Runoff from all impervious areas at the site is *not* discharging to the infiltration BMP and calculations are provided showing that the drainage area contributing runoff to the infiltration BMPs is sufficient to generate the required recharge volume.
- Recharge BMPs have been sized to infiltrate the Required Recharge Volume.
- Recharge BMPs have been sized to infiltrate the Required Recharge Volume *only* to the maximum extent practicable for the following reason:
  - Site is comprised solely of C and D soils and/or bedrock at the land surface
  - M.G.L. c. 21E sites pursuant to 310 CMR 40.0000
  - Solid Waste Landfill pursuant to 310 CMR 19.000
  - Project is otherwise subject to Stormwater Management Standards only to the maximum extent practicable.
- Calculations showing that the infiltration BMPs will drain in 72 hours are provided.
- Property includes a M.G.L. c. 21E site or a solid waste landfill and a mounding analysis is included.

<sup>1</sup> 80% TSS removal is required prior to discharge to infiltration BMP if Dynamic Field method is used.



# Checklist for Stormwater Report

---

## Checklist (continued)

### Standard 3: Recharge (continued)

- The infiltration BMP is used to attenuate peak flows during storms greater than or equal to the 10-year 24-hour storm and separation to seasonal high groundwater is less than 4 feet and a mounding analysis is provided.
- Documentation is provided showing that infiltration BMPs do not adversely impact nearby wetland resource areas.

### Standard 4: Water Quality

The Long-Term Pollution Prevention Plan typically includes the following:

- Good housekeeping practices;
  - Provisions for storing materials and waste products inside or under cover;
  - Vehicle washing controls;
  - Requirements for routine inspections and maintenance of stormwater BMPs;
  - Spill prevention and response plans;
  - Provisions for maintenance of lawns, gardens, and other landscaped areas;
  - Requirements for storage and use of fertilizers, herbicides, and pesticides;
  - Pet waste management provisions;
  - Provisions for operation and management of septic systems;
  - Provisions for solid waste management;
  - Snow disposal and plowing plans relative to Wetland Resource Areas;
  - Winter Road Salt and/or Sand Use and Storage restrictions;
  - Street sweeping schedules;
  - Provisions for prevention of illicit discharges to the stormwater management system;
  - Documentation that Stormwater BMPs are designed to provide for shutdown and containment in the event of a spill or discharges to or near critical areas or from LUHPPL;
  - Training for staff or personnel involved with implementing Long-Term Pollution Prevention Plan;
  - List of Emergency contacts for implementing Long-Term Pollution Prevention Plan.
- A Long-Term Pollution Prevention Plan is attached to Stormwater Report and is included as an attachment to the Wetlands Notice of Intent.
  - Treatment BMPs subject to the 44% TSS removal pretreatment requirement and the one inch rule for calculating the water quality volume are included, and discharge:
    - is within the Zone II or Interim Wellhead Protection Area
    - is near or to other critical areas
    - is within soils with a rapid infiltration rate (greater than 2.4 inches per hour)
    - involves runoff from land uses with higher potential pollutant loads.
  - The Required Water Quality Volume is reduced through use of the LID site Design Credits.
  - Calculations documenting that the treatment train meets the 80% TSS removal requirement and, if applicable, the 44% TSS removal pretreatment requirement, are provided.



# Checklist for Stormwater Report

## Checklist (continued)

### Standard 4: Water Quality (continued)

- The BMP is sized (and calculations provided) based on:
  - The ½" or 1" Water Quality Volume or
  - The equivalent flow rate associated with the Water Quality Volume and documentation is provided showing that the BMP treats the required water quality volume.
- The applicant proposes to use proprietary BMPs, and documentation supporting use of proprietary BMP and proposed TSS removal rate is provided. This documentation may be in the form of the propriety BMP checklist found in Volume 2, Chapter 4 of the Massachusetts Stormwater Handbook and submitting copies of the TARP Report, STEP Report, and/or other third party studies verifying performance of the proprietary BMPs.
- A TMDL exists that indicates a need to reduce pollutants other than TSS and documentation showing that the BMPs selected are consistent with the TMDL is provided.

### Standard 5: Land Uses With Higher Potential Pollutant Loads (LUHPPLs)

- The NPDES Multi-Sector General Permit covers the land use and the Stormwater Pollution Prevention Plan (SWPPP) has been included with the Stormwater Report.
- The NPDES Multi-Sector General Permit covers the land use and the SWPPP will be submitted *prior to* the discharge of stormwater to the post-construction stormwater BMPs.
- The NPDES Multi-Sector General Permit does *not* cover the land use.
- LUHPPLs are located at the site and industry specific source control and pollution prevention measures have been proposed to reduce or eliminate the exposure of LUHPPLs to rain, snow, snow melt and runoff, and been included in the long term Pollution Prevention Plan.
- All exposure has been eliminated.
- All exposure has *not* been eliminated and all BMPs selected are on MassDEP LUHPPL list.
- The LUHPPL has the potential to generate runoff with moderate to higher concentrations of oil and grease (e.g. all parking lots with >1000 vehicle trips per day) and the treatment train includes an oil grit separator, a filtering bioretention area, a sand filter or equivalent.

### Standard 6: Critical Areas

- The discharge is near or to a critical area and the treatment train includes only BMPs that MassDEP has approved for stormwater discharges to or near that particular class of critical area.
- Critical areas and BMPs are identified in the Stormwater Report.



# Checklist for Stormwater Report

## Checklist (continued)

### Standard 7: Redevelopments and Other Projects Subject to the Standards only to the maximum extent practicable

- The project is subject to the Stormwater Management Standards only to the maximum Extent Practicable as a:
- Limited Project
  - Small Residential Projects: 5-9 single family houses or 5-9 units in a multi-family development provided there is no discharge that may potentially affect a critical area.
  - Small Residential Projects: 2-4 single family houses or 2-4 units in a multi-family development with a discharge to a critical area
  - Marina and/or boatyard provided the hull painting, service and maintenance areas are protected from exposure to rain, snow, snow melt and runoff
  - Bike Path and/or Foot Path
  - Redevelopment Project
  - Redevelopment portion of mix of new and redevelopment.
- Certain standards are not fully met (Standard No. 1, 8, 9, and 10 must always be fully met) and an explanation of why these standards are not met is contained in the Stormwater Report.
- The project involves redevelopment and a description of all measures that have been taken to improve existing conditions is provided in the Stormwater Report. The redevelopment checklist found in Volume 2 Chapter 3 of the Massachusetts Stormwater Handbook may be used to document that the proposed stormwater management system (a) complies with Standards 2, 3 and the pretreatment and structural BMP requirements of Standards 4-6 to the maximum extent practicable and (b) improves existing conditions.

### Standard 8: Construction Period Pollution Prevention and Erosion and Sedimentation Control

A Construction Period Pollution Prevention and Erosion and Sedimentation Control Plan must include the following information:

- Narrative;
  - Construction Period Operation and Maintenance Plan;
  - Names of Persons or Entity Responsible for Plan Compliance;
  - Construction Period Pollution Prevention Measures;
  - Erosion and Sedimentation Control Plan Drawings;
  - Detail drawings and specifications for erosion control BMPs, including sizing calculations;
  - Vegetation Planning;
  - Site Development Plan;
  - Construction Sequencing Plan;
  - Sequencing of Erosion and Sedimentation Controls;
  - Operation and Maintenance of Erosion and Sedimentation Controls;
  - Inspection Schedule;
  - Maintenance Schedule;
  - Inspection and Maintenance Log Form.
- A Construction Period Pollution Prevention and Erosion and Sedimentation Control Plan containing the information set forth above has been included in the Stormwater Report.



# Checklist for Stormwater Report

## Checklist (continued)

### Standard 8: Construction Period Pollution Prevention and Erosion and Sedimentation Control (continued)

- The project is highly complex and information is included in the Stormwater Report that explains why it is not possible to submit the Construction Period Pollution Prevention and Erosion and Sedimentation Control Plan with the application. A Construction Period Pollution Prevention and Erosion and Sedimentation Control has **not** been included in the Stormwater Report but will be submitted **before** land disturbance begins.
- The project is **not** covered by a NPDES Construction General Permit.
- The project is covered by a NPDES Construction General Permit and a copy of the SWPPP is in the Stormwater Report.
- The project is covered by a NPDES Construction General Permit but no SWPPP been submitted. The SWPPP will be submitted BEFORE land disturbance begins.

### Standard 9: Operation and Maintenance Plan

- The Post Construction Operation and Maintenance Plan is included in the Stormwater Report and includes the following information:
  - Name of the stormwater management system owners;
  - Party responsible for operation and maintenance;
  - Schedule for implementation of routine and non-routine maintenance tasks;
  - Plan showing the location of all stormwater BMPs maintenance access areas;
  - Description and delineation of public safety features;
  - Estimated operation and maintenance budget; and
  - Operation and Maintenance Log Form.
- The responsible party is **not** the owner of the parcel where the BMP is located and the Stormwater Report includes the following submissions:
  - A copy of the legal instrument (deed, homeowner's association, utility trust or other legal entity) that establishes the terms of and legal responsibility for the operation and maintenance of the project site stormwater BMPs;
  - A plan and easement deed that allows site access for the legal entity to operate and maintain BMP functions.

### Standard 10: Prohibition of Illicit Discharges

- The Long-Term Pollution Prevention Plan includes measures to prevent illicit discharges;
- An Illicit Discharge Compliance Statement is attached;
- NO Illicit Discharge Compliance Statement is attached but will be submitted **prior to** the discharge of any stormwater to post-construction BMPs.

## STORMWATER MANAGEMENT STANDARDS

- 1. No new stormwater conveyances (e.g. outfalls) may discharge untreated stormwater directly to or cause erosion in wetlands or waters of the Commonwealth.**

There are no discharges to any waters of the Commonwealth. The project will have overflow to land of clean roof runoff.

- 2. Stormwater management systems shall be designed so that the post-development peak discharge rates do not exceed pre-development peak discharge rates.**

The runoff from the 2, 10, 25, and 100-year storms will be less than the pre-existing conditions.

- 3. Loss of annual recharge to groundwater shall be eliminated or minimized through the use of infiltration measures. A recharge rate of 0.6 inches for all impervious surfaces is required.**

All roof runoff will be recharged to the ground, at the rear of the site.

Total roof areas = 1,780 SF

$1,780 \text{ SF} \times 0.6 \text{ in} / 12 \text{ in/ft} = 89 \text{ CF}$  required recharge volume

Recharge volume provided: Roof Infiltrators = 175 CF > 89 CF.

- 4. Stormwater management systems shall be designed to remove 80% of the average annual post-construction load of Total Suspended Solids (TSS).**

Standard 4 is not applicable.

- 5. For land uses with higher potential pollutant loads, source control and pollution prevention shall be implemented.**

Standard 5 is not applicable.

- 6. Stormwater discharges within the Zone II or Interim Wellhead Protection Area of a public water supply, and stormwater discharges near or to any other critical area, require the use of the specific source control and pollution prevention measures...**

Standard 6 is not applicable.

- 7. A redevelopment project is required to meet certain Stormwater Management Standards to the maximum extent practicable.**



This project meets the Stormwater management Standards to the maximum extent practicable.

- 8. A plan to control construction related impacts including erosion, sedimentation and other pollutant sources during construction and land disturbance activities (construction period erosion, sedimentation, and pollution prevention plan) shall be developed and implemented.**

A full scale sedimentation and pollution prevention plan is not required for a site of this size, more than 100 feet from any resource area. Standard sediment control will be implemented including sediment fencing, construction fencing, and siltation cloth in catch basins adjacent to the site.

- 9. A long-term operation and maintenance plan shall be developed and implemented to ensure that stormwater management systems function as designed.**

Required maintenance practices for all stormwater facilities are included in this document. Owners documents (Condominium Association etc.) will include schedule, responsibilities, and funding for maintenance, repair and replacement as necessary).

- 10. All illicit discharges to the stormwater management system are prohibited.**

Signs prohibiting any dumping will be posted on site, prohibiting any dumping.

**PRE & POST DEVELOPMENT STORMWATER FLOWS**

**64-66 GOVE ST**

**E. BOSTON, MA**

**PROPOSED  
FLOWS**

<b><u>FREQ. STORM (YR)</u></b>	<b><u>PRE DEVEL. EXIST FLOWS (CFS)</u></b>	<b><u>ROOF INFILT. (CFS)</u></b>
2YR	0.15	0.13
10YR	0.23	0.22
25 YR	0.30	0.29
100 YR	0.44	0.42

**EXISTING CONDITIONS- HYDROCAD**

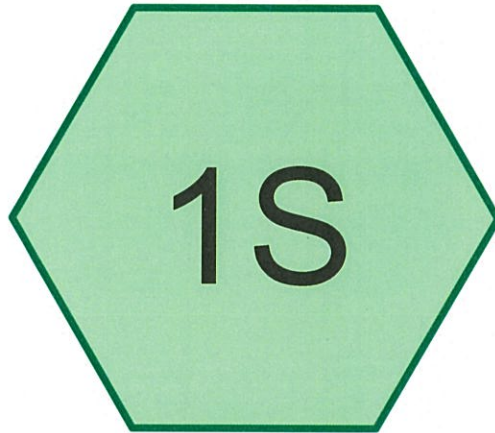

# 64-66 GOVE



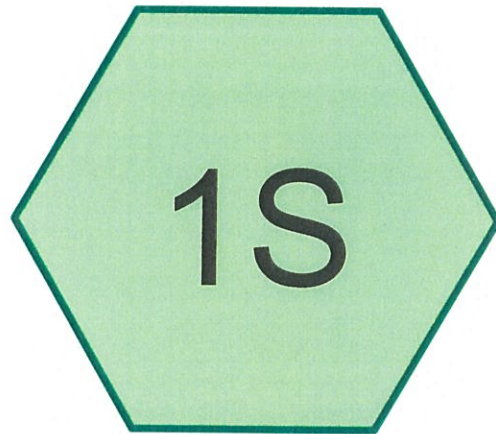

EXISTING



Routing Diagram for 3367-848 North Bedford Street-East Bridgewater  
Prepared by Civil Environmental Consultants LLC, Printed 2/26/2018  
HydroCAD® 10.00-15 s/n 09048 © 2015 HydroCAD Software Solutions LLC

**64GOVE**

**Area Listing (selected nodes)**

Area (acres)	CN	Description (subcatchment-numbers)
0.007	61	>75% Grass cover, Good, HSG B (1S)
0.045	98	Roofs, HSG B (1S)
<b>0.052</b>	<b>93</b>	<b>TOTAL AREA</b>

**64GOVE**

Prepared by Civil Environmental Consultants LLC  
HydroCAD® 10.00-15 s/n 09048 © 2015 HydroCAD Software Solutions LLC

Printed 2/26/2018

Page 3

**Soil Listing (selected nodes)**

Area (acres)	Soil Group	Subcatchment Numbers
0.000	HSG A	
0.052	HSG B	1S
0.000	HSG C	
0.000	HSG D	
0.000	Other	
<b>0.052</b>		<b>TOTAL AREA</b>

**Summary for Subcatchment 1S: 64-66 GOVE**

Runoff = 0.15 cfs @ 12.10 hrs, Volume= 0.010 af, Depth> 2.28"

Runoff by SCS TR-20 method, UH=SCS, Weighted-CN, Time Span= 5.00-20.00 hrs, dt= 0.03 hrs  
NRCC 24-hr D 2-Year Rainfall=3.26"

Area (sf)	CN	Description
1,963	98	Roofs, HSG B
317	61	>75% Grass cover, Good, HSG B
2,280	93	Weighted Average
317		13.90% Pervious Area
1,963		86.10% Impervious Area

Tc (min)	Length (feet)	Slope (ft/ft)	Velocity (ft/sec)	Capacity (cfs)	Description
4.0	50		0.21		Direct Entry, 64-66 GOVE

**Subcatchment 1S: 64-66 GOVE**

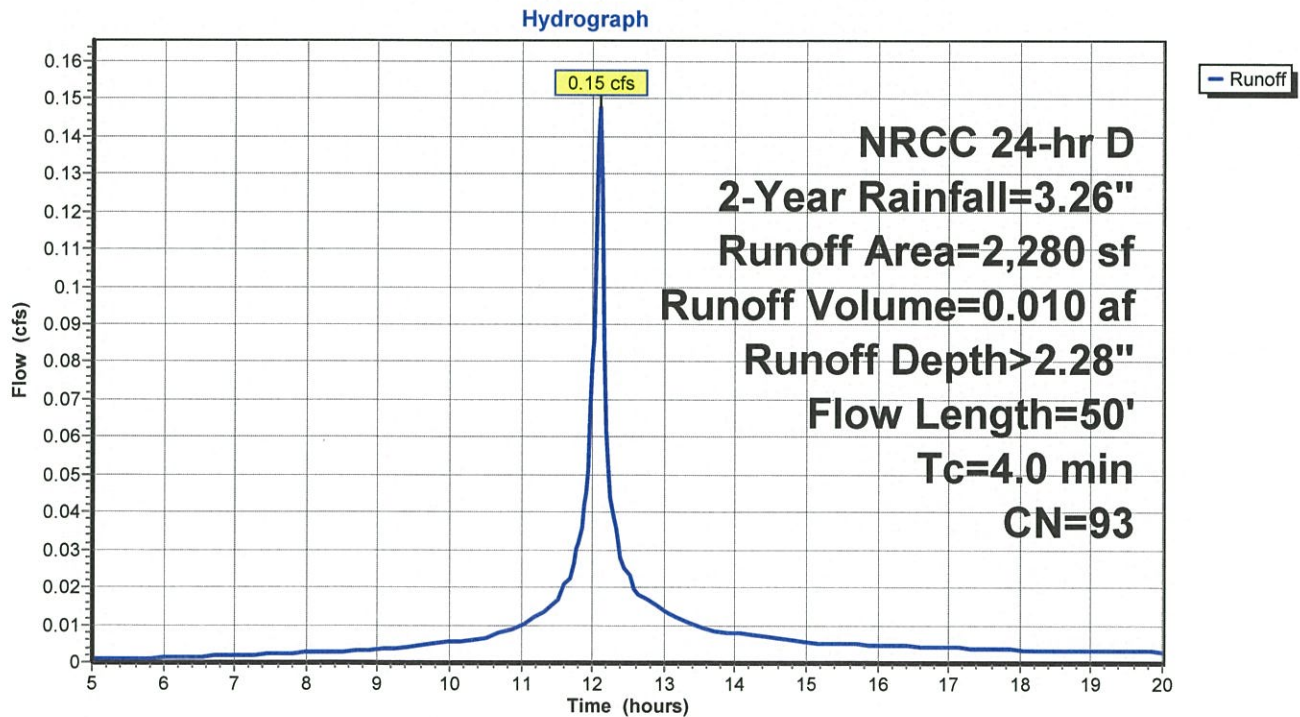



Hydrograph for Subcatchment 1S: 64-66 GOVE

Time (hours)	Precip. (inches)	Excess (inches)	Runoff (cfs)	Time (hours)	Precip. (inches)	Excess (inches)	Runoff (cfs)
5.00	0.27	0.02	0.00	12.80	2.28	1.57	0.02
5.15	0.28	0.02	0.00	12.95	2.32	1.61	0.01
5.30	0.29	0.02	0.00	13.10	2.36	1.65	0.01
5.45	0.30	0.02	0.00	13.25	2.39	1.68	0.01
5.60	0.31	0.03	0.00	13.40	2.43	1.71	0.01
5.75	0.32	0.03	0.00	13.55	2.45	1.74	0.01
5.90	0.33	0.03	0.00	13.70	2.48	1.76	0.01
6.05	0.34	0.04	0.00	13.85	2.51	1.78	0.01
6.20	0.35	0.04	0.00	14.00	2.53	1.81	0.01
6.35	0.36	0.05	0.00	14.15	2.55	1.83	0.01
6.50	0.37	0.05	0.00	14.30	2.57	1.85	0.01
6.65	0.38	0.05	0.00	14.45	2.59	1.87	0.01
6.80	0.39	0.06	0.00	14.60	2.61	1.89	0.01
6.95	0.41	0.06	0.00	14.75	2.63	1.90	0.01
7.10	0.42	0.07	0.00	14.90	2.65	1.92	0.01
7.25	0.43	0.08	0.00	15.05	2.67	1.94	0.01
7.40	0.44	0.08	0.00	15.20	2.68	1.95	0.01
7.55	0.46	0.09	0.00	15.35	2.70	1.97	0.01
7.70	0.47	0.09	0.00	15.50	2.71	1.98	0.01
7.85	0.48	0.10	0.00	15.65	2.73	2.00	0.01
8.00	0.50	0.11	0.00	15.80	2.74	2.01	0.00
8.15	0.51	0.12	0.00	15.95	2.76	2.02	0.00
8.30	0.53	0.12	0.00	16.10	2.77	2.04	0.00
8.45	0.54	0.13	0.00	16.25	2.79	2.05	0.00
8.60	0.56	0.14	0.00	16.40	2.80	2.06	0.00
8.75	0.57	0.15	0.00	16.55	2.81	2.08	0.00
8.90	0.59	0.16	0.00	16.70	2.83	2.09	0.00
9.05	0.60	0.17	0.00	16.85	2.84	2.10	0.00
9.20	0.62	0.18	0.00	17.00	2.85	2.11	0.00
9.35	0.64	0.19	0.00	17.15	2.86	2.12	0.00
9.50	0.66	0.20	0.00	17.30	2.87	2.13	0.00
9.65	0.68	0.22	0.00	17.45	2.89	2.14	0.00
9.80	0.70	0.23	0.01	17.60	2.90	2.16	0.00
9.95	0.72	0.25	0.01	17.75	2.91	2.17	0.00
10.10	0.75	0.26	0.01	17.90	2.92	2.18	0.00
10.25	0.77	0.28	0.01	18.05	2.93	2.18	0.00
10.40	0.80	0.30	0.01	18.20	2.94	2.19	0.00
10.55	0.82	0.32	0.01	18.35	2.95	2.20	0.00
10.70	0.85	0.34	0.01	18.50	2.96	2.21	0.00
10.85	0.89	0.37	0.01	18.65	2.97	2.22	0.00
11.00	0.93	0.39	0.01	18.80	2.98	2.23	0.00
11.15	0.97	0.43	0.01	18.95	2.99	2.24	0.00
11.30	1.02	0.46	0.01	19.10	3.00	2.25	0.00
11.45	1.07	0.51	0.02	19.25	3.00	2.26	0.00
11.60	1.14	0.56	0.02	19.40	3.01	2.27	0.00
11.75	1.23	0.64	0.03	19.55	3.02	2.28	0.00
11.90	1.37	0.76	0.05	19.70	3.03	2.28	0.00
12.05	1.72	1.06	<b>0.11</b>	19.85	3.04	2.29	0.00
12.20	1.99	1.31	<b>0.06</b>	20.00	<b>3.05</b>	<b>2.30</b>	0.00
12.35	2.09	1.40	0.03				
12.50	2.17	1.47	0.02				
12.65	2.22	1.52	0.02				

**Summary for Subcatchment 1S: 64-66 GOVE**

Runoff = 0.23 cfs @ 12.10 hrs, Volume= 0.016 af, Depth> 3.72"

Runoff by SCS TR-20 method, UH=SCS, Weighted-CN, Time Span= 5.00-20.00 hrs, dt= 0.03 hrs  
NRCC 24-hr D 10-Year Rainfall=4.90"

Area (sf)	CN	Description
1,963	98	Roofs, HSG B
317	61	>75% Grass cover, Good, HSG B
2,280	93	Weighted Average
317		13.90% Pervious Area
1,963		86.10% Impervious Area

Tc (min)	Length (feet)	Slope (ft/ft)	Velocity (ft/sec)	Capacity (cfs)	Description
4.0	50		0.21		Direct Entry, 64-66 GOVE

**Subcatchment 1S: 64-66 GOVE**

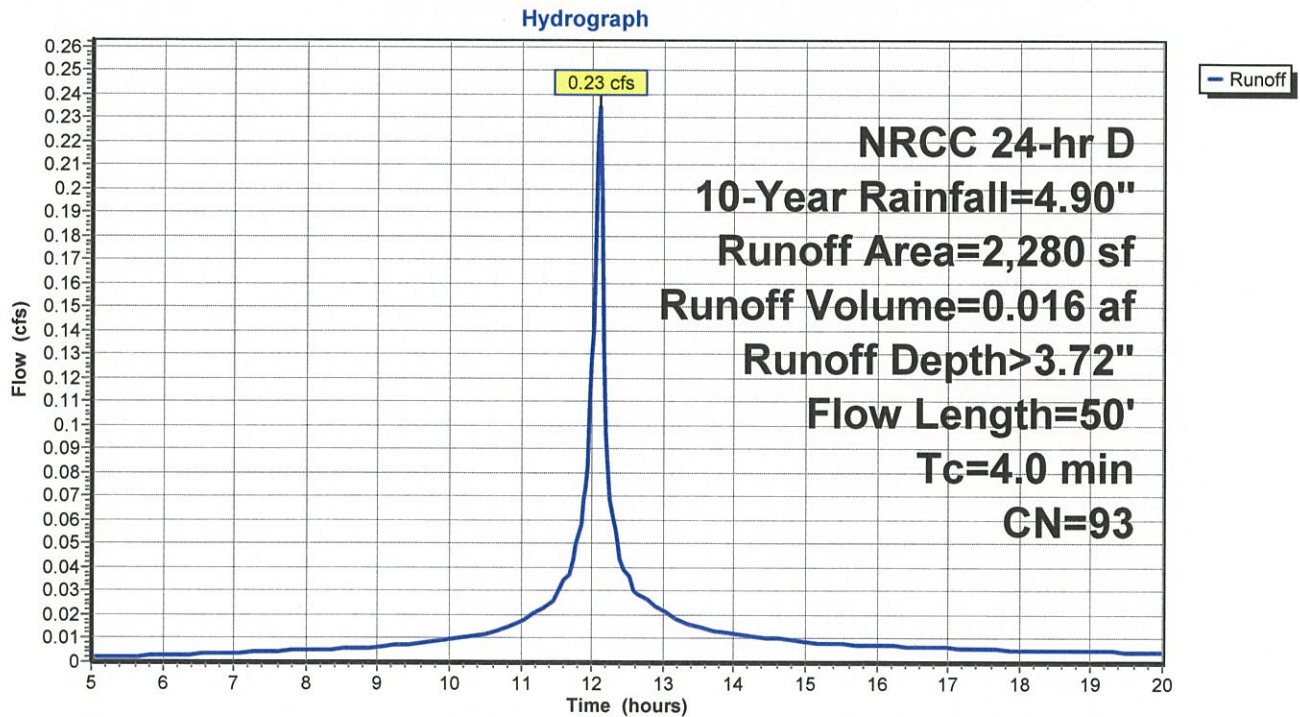

Hydrograph for Subcatchment 1S: 64-66 GOVE

Time (hours)	Precip. (inches)	Excess (inches)	Runoff (cfs)	Time (hours)	Precip. (inches)	Excess (inches)	Runoff (cfs)
5.00	0.41	0.07	0.00	12.80	3.42	2.66	0.03
5.15	0.42	0.07	0.00	12.95	3.49	2.72	0.02
5.30	0.44	0.08	0.00	13.10	3.55	2.78	0.02
5.45	0.45	0.09	0.00	13.25	3.60	2.83	0.02
5.60	0.47	0.09	0.00	13.40	3.65	2.88	0.02
5.75	0.48	0.10	0.00	13.55	3.69	2.92	0.01
5.90	0.49	0.11	0.00	13.70	3.73	2.96	0.01
6.05	0.51	0.12	0.00	13.85	3.77	2.99	0.01
6.20	0.53	0.12	0.00	14.00	3.80	3.03	0.01
6.35	0.54	0.13	0.00	14.15	3.84	3.06	0.01
6.50	0.56	0.14	0.00	14.30	3.87	3.09	0.01
6.65	0.57	0.15	0.00	14.45	3.90	3.12	0.01
6.80	0.59	0.16	0.00	14.60	3.93	3.15	0.01
6.95	0.61	0.17	0.00	14.75	3.96	3.18	0.01
7.10	0.63	0.19	0.00	14.90	3.98	3.20	0.01
7.25	0.65	0.20	0.00	15.05	4.01	3.23	0.01
7.40	0.67	0.21	0.00	15.20	4.03	3.25	0.01
7.55	0.69	0.22	0.00	15.35	4.06	3.27	0.01
7.70	0.71	0.24	0.00	15.50	4.08	3.30	0.01
7.85	0.73	0.25	0.00	15.65	4.10	3.32	0.01
8.00	0.75	0.26	0.01	15.80	4.12	3.34	0.01
8.15	0.77	0.28	0.01	15.95	4.15	3.36	0.01
8.30	0.79	0.29	0.01	16.10	4.17	3.38	0.01
8.45	0.81	0.31	0.01	16.25	4.19	3.40	0.01
8.60	0.84	0.33	0.01	16.40	4.21	3.42	0.01
8.75	0.86	0.34	0.01	16.55	4.23	3.44	0.01
8.90	0.88	0.36	0.01	16.70	4.25	3.46	0.01
9.05	0.91	0.38	0.01	16.85	4.27	3.48	0.01
9.20	0.93	0.40	0.01	17.00	4.28	3.50	0.01
9.35	0.96	0.42	0.01	17.15	4.30	3.51	0.01
9.50	0.99	0.44	0.01	17.30	4.32	3.53	0.01
9.65	1.02	0.47	0.01	17.45	4.34	3.55	0.01
9.80	1.05	0.49	0.01	17.60	4.35	3.56	0.01
9.95	1.09	0.52	0.01	17.75	4.37	3.58	0.01
10.10	1.12	0.55	0.01	17.90	4.39	3.60	0.01
10.25	1.16	0.58	0.01	18.05	4.40	3.61	0.01
10.40	1.20	0.61	0.01	18.20	4.42	3.62	0.01
10.55	1.24	0.64	0.01	18.35	4.43	3.64	0.01
10.70	1.28	0.68	0.01	18.50	4.44	3.65	0.01
10.85	1.34	0.72	0.02	18.65	4.46	3.67	0.00
11.00	1.39	0.77	0.02	18.80	4.47	3.68	0.00
11.15	1.46	0.83	0.02	18.95	4.49	3.70	0.00
11.30	1.53	0.89	0.02	19.10	4.50	3.71	0.00
11.45	1.61	0.97	0.03	19.25	4.52	3.72	0.00
11.60	1.72	1.06	0.03	19.40	4.53	3.74	0.00
11.75	1.85	1.18	0.04	19.55	4.54	3.75	0.00
11.90	2.07	1.37	0.07	19.70	4.56	3.76	0.00
12.05	2.59	1.87	<b>0.18</b>	19.85	4.57	3.78	0.00
12.20	2.99	2.25	<b>0.10</b>	20.00	<b>4.58</b>	<b>3.79</b>	0.00
12.35	3.14	2.39	0.05				
12.50	3.26	2.50	0.04				
12.65	3.34	2.58	0.03				

**Summary for Subcatchment 1S: 64-66 GOVE**

Runoff = 0.30 cfs @ 12.10 hrs, Volume= 0.021 af, Depth> 4.86"

Runoff by SCS TR-20 method, UH=SCS, Weighted-CN, Time Span= 5.00-20.00 hrs, dt= 0.03 hrs  
NRCC 24-hr D 25-Year Rainfall=6.19"

Area (sf)	CN	Description
1,963	98	Roofs, HSG B
317	61	>75% Grass cover, Good, HSG B
2,280	93	Weighted Average
317		13.90% Pervious Area
1,963		86.10% Impervious Area

Tc (min)	Length (feet)	Slope (ft/ft)	Velocity (ft/sec)	Capacity (cfs)	Description
4.0	50		0.21		Direct Entry, 64-66 GOVE

**Subcatchment 1S: 64-66 GOVE**

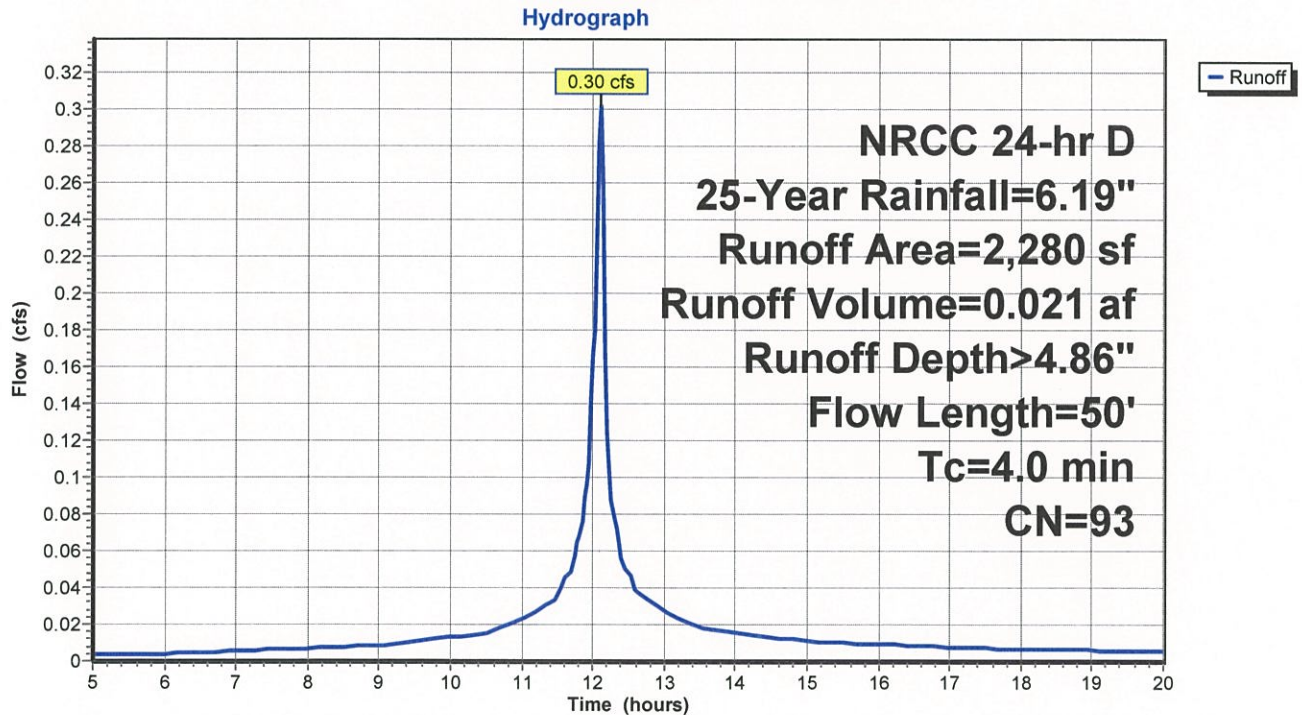

Hydrograph for Subcatchment 1S: 64-66 GOVE

Time (hours)	Precip. (inches)	Excess (inches)	Runoff (cfs)	Time (hours)	Precip. (inches)	Excess (inches)	Runoff (cfs)
5.00	0.51	0.12	0.00	12.80	4.32	3.53	0.03
5.15	0.53	0.13	0.00	12.95	4.40	3.61	0.03
5.30	0.55	0.14	0.00	13.10	4.48	3.69	0.03
5.45	0.57	0.15	0.00	13.25	4.55	3.75	0.02
5.60	0.59	0.16	0.00	13.40	4.61	3.81	0.02
5.75	0.61	0.17	0.00	13.55	4.66	3.86	0.02
5.90	0.63	0.18	0.00	13.70	4.71	3.91	0.02
6.05	0.64	0.20	0.00	13.85	4.76	3.96	0.02
6.20	0.66	0.21	0.00	14.00	4.80	4.00	0.02
6.35	0.68	0.22	0.00	14.15	4.85	4.05	0.01
6.50	0.70	0.23	0.00	14.30	4.89	4.09	0.01
6.65	0.73	0.25	0.01	14.45	4.93	4.13	0.01
6.80	0.75	0.26	0.01	14.60	4.96	4.16	0.01
6.95	0.77	0.28	0.01	14.75	5.00	4.20	0.01
7.10	0.79	0.30	0.01	14.90	5.03	4.23	0.01
7.25	0.82	0.31	0.01	15.05	5.06	4.26	0.01
7.40	0.84	0.33	0.01	15.20	5.09	4.29	0.01
7.55	0.87	0.35	0.01	15.35	5.12	4.32	0.01
7.70	0.89	0.37	0.01	15.50	5.15	4.35	0.01
7.85	0.92	0.39	0.01	15.65	5.18	4.38	0.01
8.00	0.94	0.41	0.01	15.80	5.21	4.40	0.01
8.15	0.97	0.43	0.01	15.95	5.24	4.43	0.01
8.30	1.00	0.45	0.01	16.10	5.26	4.46	0.01
8.45	1.03	0.47	0.01	16.25	5.29	4.48	0.01
8.60	1.06	0.49	0.01	16.40	5.32	4.51	0.01
8.75	1.09	0.52	0.01	16.55	5.34	4.53	0.01
8.90	1.12	0.54	0.01	16.70	5.37	4.56	0.01
9.05	1.15	0.57	0.01	16.85	5.39	4.58	0.01
9.20	1.18	0.59	0.01	17.00	5.41	4.60	0.01
9.35	1.21	0.62	0.01	17.15	5.44	4.63	0.01
9.50	1.25	0.65	0.01	17.30	5.46	4.65	0.01
9.65	1.29	0.69	0.01	17.45	5.48	4.67	0.01
9.80	1.33	0.72	0.01	17.60	5.50	4.69	0.01
9.95	1.37	0.76	0.01	17.75	5.52	4.71	0.01
10.10	1.42	0.80	0.01	17.90	5.54	4.73	0.01
10.25	1.46	0.84	0.01	18.05	5.56	4.75	0.01
10.40	1.51	0.88	0.01	18.20	5.58	4.77	0.01
10.55	1.56	0.92	0.02	18.35	5.60	4.78	0.01
10.70	1.62	0.97	0.02	18.50	5.61	4.80	0.01
10.85	1.69	1.03	0.02	18.65	5.63	4.82	0.01
11.00	1.76	1.10	0.02	18.80	5.65	4.84	0.01
11.15	1.84	1.17	0.03	18.95	5.67	4.86	0.01
11.30	1.93	1.25	0.03	19.10	5.69	4.87	0.01
11.45	2.04	1.35	0.03	19.25	5.70	4.89	0.01
11.60	2.17	1.47	0.05	19.40	5.72	4.91	0.01
11.75	2.34	1.63	0.06	19.55	5.74	4.93	0.01
11.90	2.61	1.88	0.10	19.70	5.76	4.94	0.01
12.05	3.27	2.52	<b>0.23</b>	19.85	5.77	4.96	0.01
12.20	3.78	3.01	<b>0.12</b>	20.00	<b>5.79</b>	<b>4.98</b>	0.01
12.35	3.97	3.19	0.06				
12.50	4.12	3.33	0.05				
12.65	4.22	3.44	0.04				

**Summary for Subcatchment 1S: 64-66 GOVE**

Runoff = 0.44 cfs @ 12.10 hrs, Volume= 0.031 af, Depth> 7.17"

Runoff by SCS TR-20 method, UH=SCS, Weighted-CN, Time Span= 5.00-20.00 hrs, dt= 0.03 hrs  
NRCC 24-hr D 100-Year Rainfall=8.83"

Area (sf)	CN	Description
1,963	98	Roofs, HSG B
317	61	>75% Grass cover, Good, HSG B
2,280	93	Weighted Average
317		13.90% Pervious Area
1,963		86.10% Impervious Area

Tc (min)	Length (feet)	Slope (ft/ft)	Velocity (ft/sec)	Capacity (cfs)	Description
4.0	50		0.21		Direct Entry, 64-66 GOVE

**Subcatchment 1S: 64-66 GOVE**

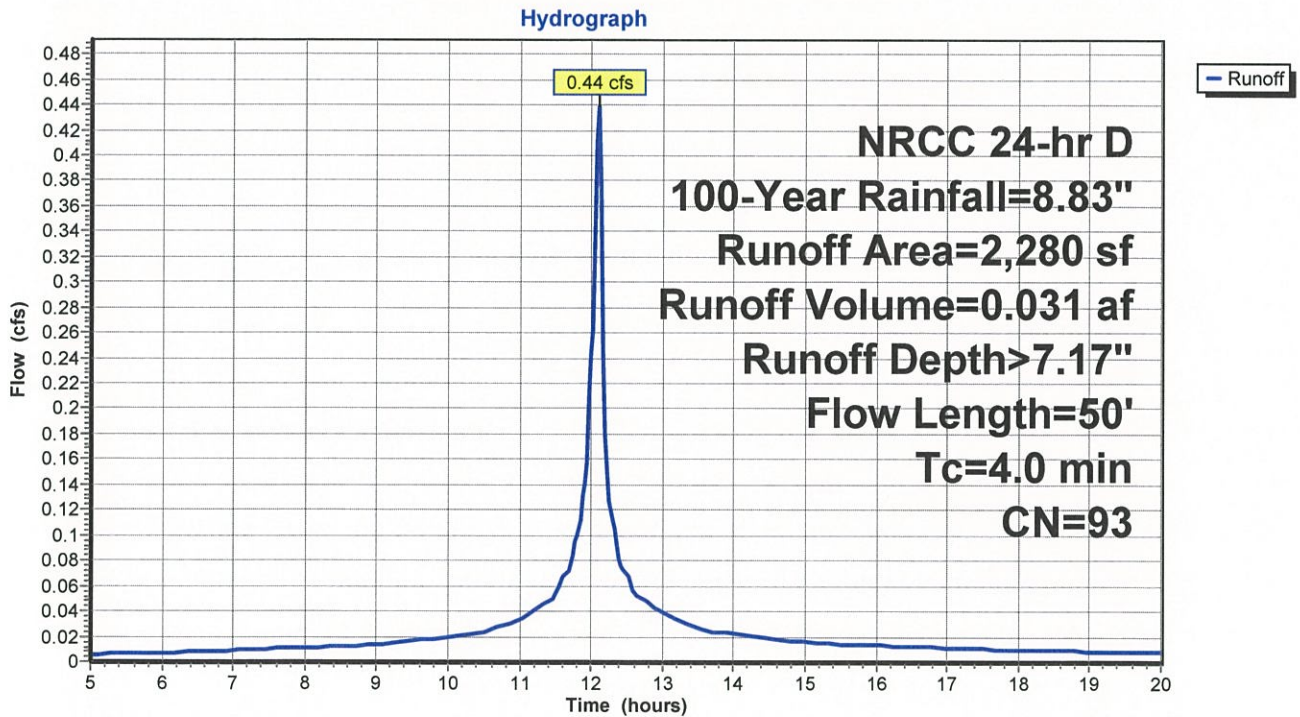

## Hydrograph for Subcatchment 1S: 64-66 GOVE

Time (hours)	Precip. (inches)	Excess (inches)	Runoff (cfs)	Time (hours)	Precip. (inches)	Excess (inches)	Runoff (cfs)
5.00	0.73	0.26	0.01	12.80	6.16	5.34	0.05
5.15	0.76	0.27	0.01	12.95	6.28	5.46	0.04
5.30	0.79	0.29	0.01	13.10	6.39	5.57	0.04
5.45	0.81	0.31	0.01	13.25	6.49	5.66	0.03
5.60	0.84	0.33	0.01	13.40	6.57	5.75	0.03
5.75	0.86	0.35	0.01	13.55	6.65	5.82	0.03
5.90	0.89	0.37	0.01	13.70	6.72	5.89	0.02
6.05	0.92	0.39	0.01	13.85	6.79	5.96	0.02
6.20	0.95	0.41	0.01	14.00	6.85	6.02	0.02
6.35	0.98	0.43	0.01	14.15	6.91	6.08	0.02
6.50	1.00	0.45	0.01	14.30	6.97	6.14	0.02
6.65	1.04	0.48	0.01	14.45	7.03	6.20	0.02
6.80	1.07	0.50	0.01	14.60	7.08	6.25	0.02
6.95	1.10	0.53	0.01	14.75	7.13	6.30	0.02
7.10	1.13	0.55	0.01	14.90	7.18	6.35	0.02
7.25	1.16	0.58	0.01	15.05	7.22	6.39	0.02
7.40	1.20	0.61	0.01	15.20	7.27	6.44	0.02
7.55	1.23	0.64	0.01	15.35	7.31	6.48	0.01
7.70	1.27	0.67	0.01	15.50	7.35	6.52	0.01
7.85	1.31	0.70	0.01	15.65	7.39	6.56	0.01
8.00	1.35	0.73	0.01	15.80	7.43	6.60	0.01
8.15	1.39	0.77	0.01	15.95	7.47	6.64	0.01
8.30	1.42	0.80	0.01	16.10	7.51	6.68	0.01
8.45	1.47	0.84	0.01	16.25	7.55	6.71	0.01
8.60	1.51	0.87	0.01	16.40	7.58	6.75	0.01
8.75	1.55	0.91	0.01	16.55	7.62	6.78	0.01
8.90	1.59	0.95	0.01	16.70	7.65	6.82	0.01
9.05	1.64	0.99	0.01	16.85	7.69	6.85	0.01
9.20	1.68	1.03	0.01	17.00	7.72	6.89	0.01
9.35	1.73	1.07	0.02	17.15	7.75	6.92	0.01
9.50	1.78	1.12	0.02	17.30	7.78	6.95	0.01
9.65	1.84	1.17	0.02	17.45	7.82	6.98	0.01
9.80	1.90	1.22	0.02	17.60	7.85	7.01	0.01
9.95	1.96	1.28	0.02	17.75	7.87	7.04	0.01
10.10	2.02	1.34	0.02	17.90	7.90	7.07	0.01
10.25	2.09	1.40	0.02	18.05	7.93	7.09	0.01
10.40	2.16	1.46	0.02	18.20	7.96	7.12	0.01
10.55	2.23	1.53	0.02	18.35	7.98	7.15	0.01
10.70	2.31	1.60	0.03	18.50	8.01	7.17	0.01
10.85	2.41	1.69	0.03	18.65	8.04	7.20	0.01
11.00	2.51	1.79	0.03	18.80	8.06	7.22	0.01
11.15	2.63	1.90	0.04	18.95	8.09	7.25	0.01
11.30	2.76	2.02	0.04	19.10	8.11	7.27	0.01
11.45	2.91	2.16	0.05	19.25	8.14	7.30	0.01
11.60	3.09	2.34	0.07	19.40	8.16	7.32	0.01
11.75	3.34	2.58	0.08	19.55	8.19	7.35	0.01
11.90	3.72	2.95	0.14	19.70	8.21	7.37	0.01
12.05	4.67	3.87	<b>0.33</b>	19.85	8.24	7.40	0.01
12.20	5.39	4.58	<b>0.18</b>	20.00	<b>8.26</b>	<b>7.42</b>	0.01
12.35	5.66	4.85	0.09				
12.50	5.87	5.06	0.07				
12.65	6.02	5.21	0.05				

**PROPOSED CONDITIONS - HYDROCAD**





64-66  
GOVE-PROPOSED

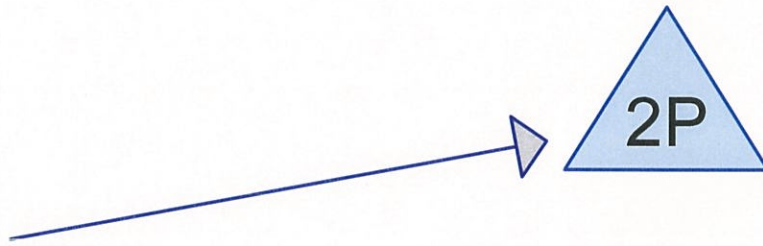

ROOF INFILTRATION



**64GOVE**

Prepared by Civil Environmental Consultants LLC  
HydroCAD® 10.00-15 s/n 09048 © 2015 HydroCAD Software Solutions LLC

Printed 2/26/2018

Page 2

**Area Listing (selected nodes)**

Area (acres)	CN	Description (subcatchment-numbers)
0.011	61	>75% Grass cover, Good, HSG B (3S)
0.041	98	Roofs, HSG B (3S)
<b>0.052</b>	<b>90</b>	<b>TOTAL AREA</b>

**64GOVE****Soil Listing (selected nodes)**

Area (acres)	Soil Group	Subcatchment Numbers
0.000	HSG A	
0.052	HSG B	3S
0.000	HSG C	
0.000	HSG D	
0.000	Other	
<b>0.052</b>		<b>TOTAL AREA</b>

Pond 2P: ROOF INFILTRATION

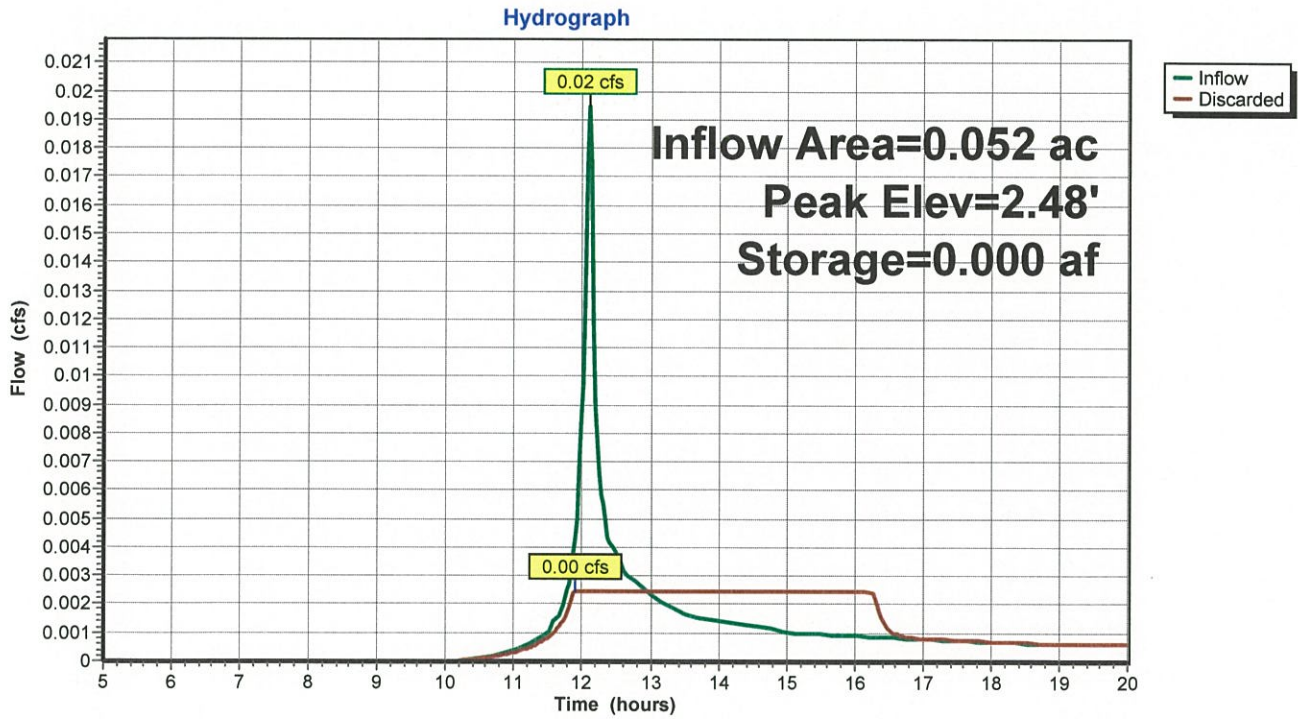

**Summary for Pond 2P: ROOF INFILTRATION**

Inflow Area = 0.052 ac, 78.07% Impervious, Inflow Depth > 0.28"  
 Inflow = 0.02 cfs @ 12.11 hrs, Volume= 0.001 af  
 Outflow = 0.00 cfs @ 11.90 hrs, Volume= 0.001 af, Atten= 87%, Lag= 0.0 min  
 Discarded = 0.00 cfs @ 11.90 hrs, Volume= 0.001 af

Routing by Stor-Ind method, Time Span= 5.00-20.00 hrs, dt= 0.03 hrs  
 Peak Elev= 2.48' @ 12.95 hrs Surf.Area= 0.002 ac Storage= 0.000 af

Plug-Flow detention time= 51.5 min calculated for 0.001 af (99% of inflow)  
 Center-of-Mass det. time= 49.6 min ( 879.8 - 830.2 )

Volume	Invert	Avail.Storage	Storage Description
#1A	2.00'	0.002 af	<b>6.25'W x 16.68'L x 3.50'H Field A</b> 0.008 af Overall - 0.002 af Embedded = 0.006 af x 30.0% Voids
#2A	2.50'	0.002 af	<b>ADS_StormTech SC-740 x 2 Inside #1</b> Effective Size= 44.6"W x 30.0"H => 6.45 sf x 7.12'L = 45.9 cf Overall Size= 51.0"W x 30.0"H x 7.56'L with 0.44' Overlap Row Length Adjustment= +0.44' x 6.45 sf x 1 rows
		0.004 af	Total Available Storage

Storage Group A created with Chamber Wizard

Device	Routing	Invert	Outlet Devices
#1	Discarded	2.00'	<b>1.020 in/hr Exfiltration over Surface area</b>

**Discarded OutFlow** Max=0.00 cfs @ 11.90 hrs HW=2.04' (Free Discharge)  
 ↑1=Exfiltration (Exfiltration Controls 0.00 cfs)

**64GOVE**

Prepared by Civil Environmental Consultants LLC  
HydroCAD® 10.00-15 s/n 09048 © 2015 HydroCAD Software Solutions LLC

Printed 2/27/2018  
Page 4

**Pipe Listing (selected nodes)**

Line#	Node Number	In-Invert (feet)	Out-Invert (feet)	Length (feet)	Slope (ft/ft)	n	Diam/Width (inches)	Height (inches)	Inside-Fill (inches)
1	2P	3.00	2.50	40.0	0.0125	0.010	6.0	0.0	0.0

Summary for Subcatchment 3S: 64-66 GOVE-PROPOSED

Runoff = 0.14 cfs @ 12.11 hrs, Volume= 0.009 af, Depth> 2.18"

Runoff by SCS TR-20 method, UH=SCS, Weighted-CN, Time Span= 1.00-23.00 hrs, dt= 0.01 hrs  
NRCC 24-hr D 2-Year Rainfall=3.26"

Area (sf)	CN	Description
1,780	98	Roofs, HSG B
500	61	>75% Grass cover, Good, HSG B
2,280	90	Weighted Average
500		21.93% Pervious Area
1,780		78.07% Impervious Area

Tc (min)	Length (feet)	Slope (ft/ft)	Velocity (ft/sec)	Capacity (cfs)	Description
4.0	50		0.21		Direct Entry, 64-66 GOVE

Subcatchment 3S: 64-66 GOVE-PROPOSED

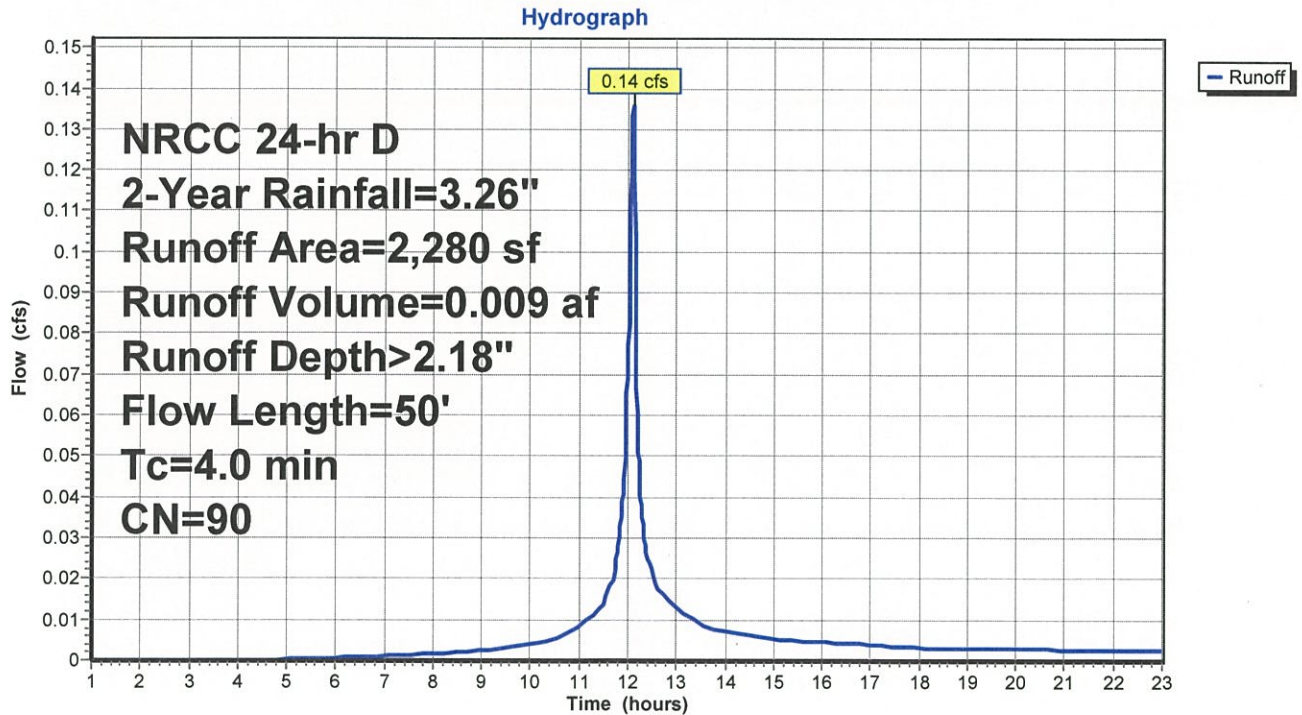

## Hydrograph for Subcatchment 3S: 64-66 GOVE-PROPOSED

Time (hours)	Precip. (inches)	Excess (inches)	Runoff (cfs)
1.00	0.05	0.00	0.00
1.50	0.07	0.00	0.00
2.00	0.10	0.00	0.00
2.50	0.12	0.00	0.00
3.00	0.15	0.00	0.00
3.50	0.18	0.00	0.00
4.00	0.21	0.00	0.00
4.50	0.24	0.00	0.00
5.00	0.27	0.00	0.00
5.50	0.30	0.01	0.00
6.00	0.34	0.01	0.00
6.50	0.37	0.02	0.00
7.00	0.41	0.03	0.00
7.50	0.45	0.04	0.00
8.00	0.50	0.05	0.00
8.50	0.55	0.07	0.00
9.00	0.60	0.10	0.00
9.50	0.66	0.12	0.00
10.00	0.73	0.16	0.00
10.50	0.81	0.21	0.01
11.00	0.93	0.27	0.01
11.50	1.09	0.38	0.01
12.00	1.56	0.73	<b>0.07</b>
12.50	2.17	1.24	<b>0.02</b>
13.00	2.33	1.38	0.01
13.50	2.45	1.48	0.01
14.00	2.53	1.56	0.01
14.50	2.60	1.62	0.01
15.00	2.66	1.68	0.01
15.50	2.71	1.72	0.00
16.00	2.76	1.77	0.00
16.50	2.81	1.81	0.00
17.00	2.85	1.85	0.00
17.50	2.89	1.88	0.00
18.00	2.92	1.91	0.00
18.50	2.96	1.94	0.00
19.00	2.99	1.97	0.00
19.50	3.02	2.00	0.00
20.00	3.05	2.03	0.00
20.50	3.08	2.06	0.00
21.00	3.11	2.08	0.00
21.50	3.14	2.11	0.00
22.00	3.16	2.13	0.00
22.50	3.19	2.16	0.00
23.00	<b>3.21</b>	<b>2.18</b>	0.00



**Summary for Pond 2P: ROOF INFILTRATION**

Inflow Area = 0.052 ac, 78.07% Impervious, Inflow Depth > 2.18" for 2-Year event  
 Inflow = 0.14 cfs @ 12.11 hrs, Volume= 0.009 af  
 Outflow = 0.13 cfs @ 12.13 hrs, Volume= 0.008 af, Atten= 2%, Lag= 0.7 min  
 Discarded = 0.00 cfs @ 9.09 hrs, Volume= 0.003 af  
 Primary = 0.13 cfs @ 12.13 hrs, Volume= 0.005 af

Routing by Stor-Ind method, Time Span= 1.00-23.00 hrs, dt= 0.01 hrs  
 Peak Elev= 3.22' @ 12.13 hrs Surf.Area= 0.002 ac Storage= 0.001 af

Plug-Flow detention time= 80.3 min calculated for 0.008 af (88% of inflow)  
 Center-of-Mass det. time= 23.1 min ( 831.9 - 808.8 )

Volume	Invert	Avail.Storage	Storage Description
#1A	2.00'	0.002 af	<b>6.25'W x 16.68'L x 3.50'H Field A</b> 0.008 af Overall - 0.002 af Embedded = 0.006 af x 30.0% Voids
#2A	2.50'	0.002 af	<b>ADS_StormTech SC-740 x 2 Inside #1</b> Effective Size= 44.6"W x 30.0"H => 6.45 sf x 7.12'L = 45.9 cf Overall Size= 51.0"W x 30.0"H x 7.56'L with 0.44' Overlap Row Length Adjustment= +0.44' x 6.45 sf x 1 rows
		0.004 af	Total Available Storage

Storage Group A created with Chamber Wizard

Device	Routing	Invert	Outlet Devices
#1	Discarded	2.00'	<b>1.020 in/hr Exfiltration over Surface area</b>
#2	Primary	3.00'	<b>6.0" Round Culvert L= 40.0' Ke= 0.500</b> Inlet / Outlet Invert= 3.00' / 2.50' S= 0.0125 '/ Cc= 0.900 n= 0.010 PVC, smooth interior, Flow Area= 0.20 sf

**Discarded OutFlow** Max=0.00 cfs @ 9.09 hrs HW=2.04' (Free Discharge)  
 ↑1=Exfiltration (Exfiltration Controls 0.00 cfs)

**Primary OutFlow** Max=0.13 cfs @ 12.13 hrs HW=3.22' (Free Discharge)  
 ↑2=Culvert (Inlet Controls 0.13 cfs @ 1.58 fps)

**Pond 2P: ROOF INFILTRATION - Chamber Wizard Field A**

**Chamber Model = ADS\_StormTech SC-740 (ADS StormTech® SC-740)**

Effective Size= 44.6"W x 30.0"H => 6.45 sf x 7.12'L = 45.9 cf

Overall Size= 51.0"W x 30.0"H x 7.56'L with 0.44' Overlap

Row Length Adjustment= +0.44' x 6.45 sf x 1 rows

2 Chambers/Row x 7.12' Long +0.44' Row Adjustment = 14.68' Row Length +12.0" End Stone x 2 = 16.68' Base Length

1 Rows x 51.0" Wide + 12.0" Side Stone x 2 = 6.25' Base Width

6.0" Base + 30.0" Chamber Height + 6.0" Cover = 3.50' Field Height

2 Chambers x 45.9 cf +0.44' Row Adjustment x 6.45 sf x 1 Rows = 94.7 cf Chamber Storage

364.9 cf Field - 94.7 cf Chambers = 270.2 cf Stone x 30.0% Voids = 81.0 cf Stone Storage

Chamber Storage + Stone Storage = 175.8 cf = 0.004 af

Overall Storage Efficiency = 48.2%

2 Chambers

13.5 cy Field

10.0 cy Stone

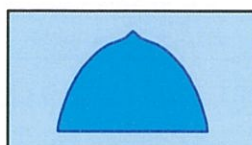
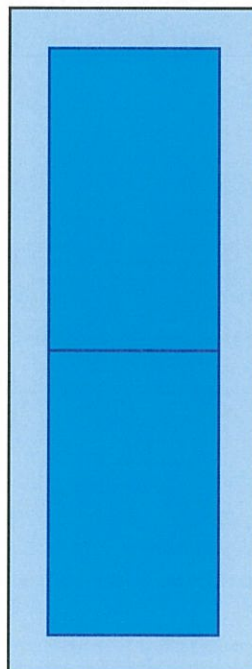

### Pond 2P: ROOF INFILTRATION

Hydrograph

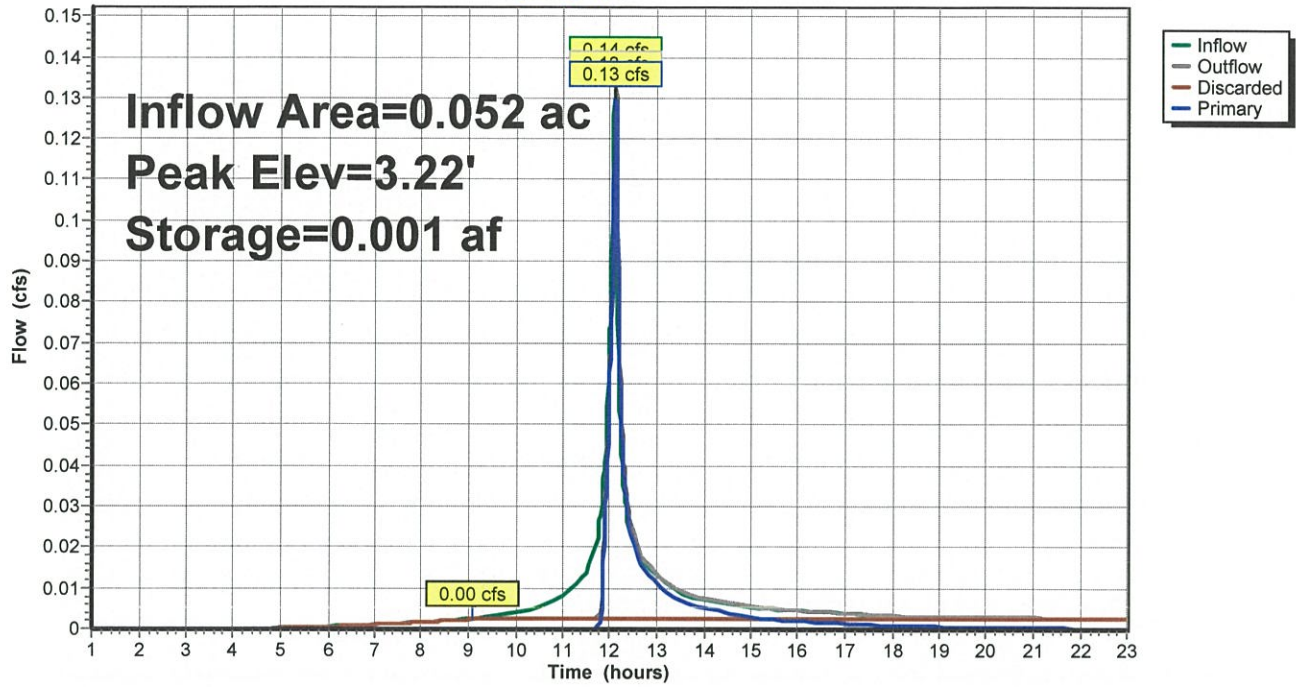

**Hydrograph for Pond 2P: ROOF INFILTRATION**

Time (hours)	Inflow (cfs)	Storage (acre-feet)	Elevation (feet)	Outflow (cfs)	Discarded (cfs)	Primary (cfs)
1.00	0.00	0.000	2.00	0.00	0.00	0.00
1.50	0.00	0.000	2.00	0.00	0.00	0.00
2.00	0.00	0.000	2.00	0.00	0.00	0.00
2.50	0.00	0.000	2.00	0.00	0.00	0.00
3.00	0.00	0.000	2.00	0.00	0.00	0.00
3.50	0.00	0.000	2.00	0.00	0.00	0.00
4.00	0.00	0.000	2.00	0.00	0.00	0.00
4.50	0.00	0.000	2.00	0.00	0.00	0.00
5.00	0.00	0.000	2.00	0.00	0.00	0.00
5.50	0.00	0.000	2.01	0.00	0.00	0.00
6.00	0.00	0.000	2.01	0.00	0.00	0.00
6.50	0.00	0.000	2.01	0.00	0.00	0.00
7.00	0.00	0.000	2.01	0.00	0.00	0.00
7.50	0.00	0.000	2.02	0.00	0.00	0.00
8.00	0.00	0.000	2.02	0.00	0.00	0.00
8.50	0.00	0.000	2.03	0.00	0.00	0.00
9.00	0.00	0.000	2.03	0.00	<b>0.00</b>	0.00
9.50	0.00	0.000	2.06	0.00	<b>0.00</b>	0.00
10.00	0.00	0.000	2.13	0.00	0.00	0.00
10.50	0.01	0.000	2.26	0.00	0.00	0.00
11.00	0.01	0.000	2.50	0.00	0.00	0.00
11.50	0.01	0.001	2.72	0.00	0.00	0.00
12.00	<b>0.07</b>	<b>0.001</b>	<b>3.15</b>	<b>0.07</b>	0.00	<b>0.06</b>
12.50	<b>0.02</b>	<b>0.001</b>	<b>3.08</b>	<b>0.02</b>	0.00	<b>0.02</b>
13.00	0.01	0.001	3.06	0.01	0.00	0.01
13.50	0.01	0.001	3.05	0.01	0.00	0.01
14.00	0.01	0.001	3.04	0.01	0.00	0.01
14.50	0.01	0.001	3.03	0.01	0.00	0.00
15.00	0.01	0.001	3.03	0.01	0.00	0.00
15.50	0.00	0.001	3.02	0.00	0.00	0.00
16.00	0.00	0.001	3.02	0.00	0.00	0.00
16.50	0.00	0.001	3.02	0.00	0.00	0.00
17.00	0.00	0.001	3.02	0.00	0.00	0.00
17.50	0.00	0.001	3.02	0.00	0.00	0.00
18.00	0.00	0.001	3.02	0.00	0.00	0.00
18.50	0.00	0.001	3.01	0.00	0.00	0.00
19.00	0.00	0.001	3.01	0.00	0.00	0.00
19.50	0.00	0.001	3.01	0.00	0.00	0.00
20.00	0.00	0.001	3.01	0.00	0.00	0.00
20.50	0.00	0.001	3.01	0.00	0.00	0.00
21.00	0.00	0.001	3.01	0.00	0.00	0.00
21.50	0.00	0.001	3.01	0.00	0.00	0.00
22.00	0.00	0.001	3.00	0.00	0.00	0.00
22.50	0.00	0.001	3.00	0.00	0.00	0.00
23.00	0.00	0.001	3.00	0.00	0.00	0.00

**Summary for Subcatchment 3S: 64-66 GOVE-PROPOSED**

Runoff = 0.22 cfs @ 12.11 hrs, Volume= 0.016 af, Depth> 3.71"

Runoff by SCS TR-20 method, UH=SCS, Weighted-CN, Time Span= 1.00-23.00 hrs, dt= 0.01 hrs  
NRCC 24-hr D 10-Year Rainfall=4.90"

Area (sf)	CN	Description
1,780	98	Roofs, HSG B
500	61	>75% Grass cover, Good, HSG B
2,280	90	Weighted Average
500		21.93% Pervious Area
1,780		78.07% Impervious Area

Tc (min)	Length (feet)	Slope (ft/ft)	Velocity (ft/sec)	Capacity (cfs)	Description
4.0	50		0.21		Direct Entry, 64-66 GOVE

**Subcatchment 3S: 64-66 GOVE-PROPOSED**

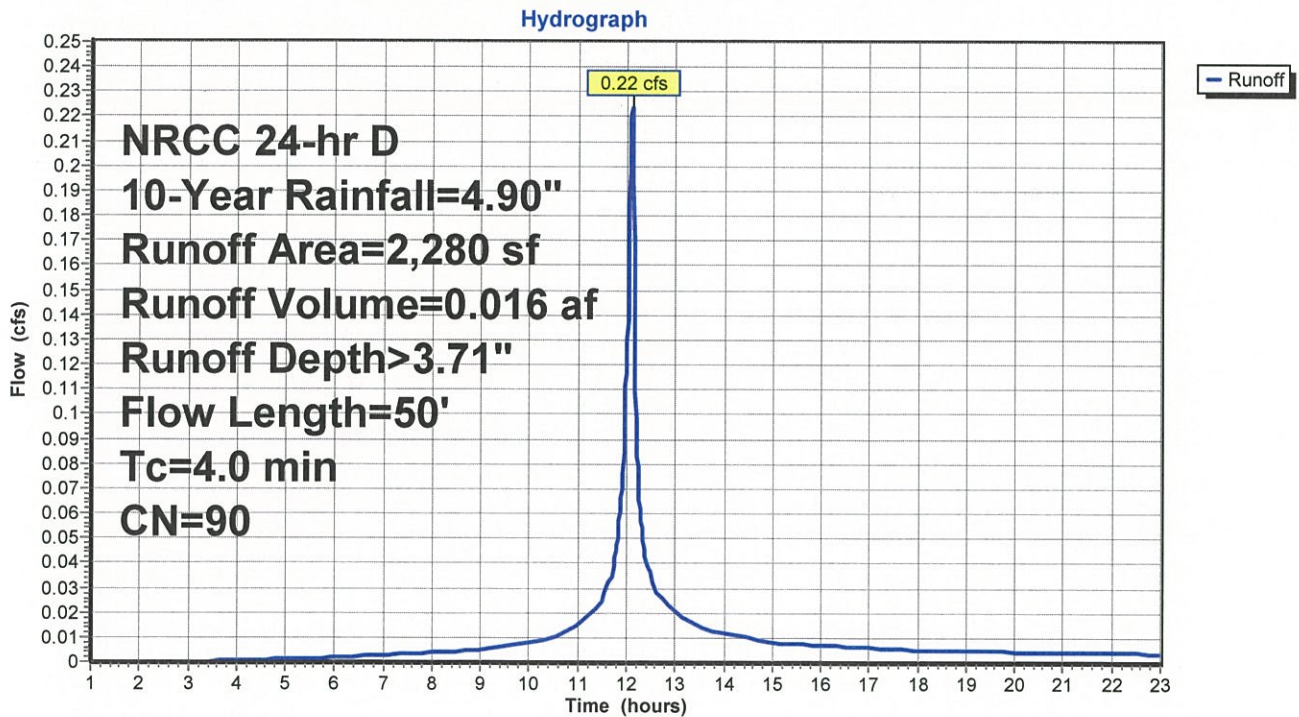

## Hydrograph for Subcatchment 3S: 64-66 GOVE-PROPOSED

Time (hours)	Precip. (inches)	Excess (inches)	Runoff (cfs)
1.00	0.07	0.00	0.00
1.50	0.11	0.00	0.00
2.00	0.15	0.00	0.00
2.50	0.19	0.00	0.00
3.00	0.23	0.00	0.00
3.50	0.27	0.00	0.00
4.00	0.32	0.01	0.00
4.50	0.36	0.02	0.00
5.00	0.41	0.03	0.00
5.50	0.46	0.04	0.00
6.00	0.50	0.06	0.00
6.50	0.56	0.08	0.00
7.00	0.62	0.10	0.00
7.50	0.68	0.13	0.00
8.00	0.75	0.17	0.00
8.50	0.82	0.21	0.00
9.00	0.90	0.26	0.01
9.50	0.99	0.31	0.01
10.00	1.10	0.39	0.01
10.50	1.22	0.47	0.01
11.00	1.39	0.60	0.02
11.50	1.64	0.80	0.02
12.00	2.35	1.40	<b>0.12</b>
12.50	3.26	2.22	<b>0.04</b>
13.00	3.51	2.46	0.02
13.50	3.68	2.61	0.01
14.00	3.80	2.73	0.01
14.50	3.91	2.83	0.01
15.00	4.00	2.92	0.01
15.50	4.08	2.99	0.01
16.00	4.15	3.06	0.01
16.50	4.22	3.13	0.01
17.00	4.28	3.19	0.01
17.50	4.34	3.25	0.01
18.00	4.40	3.30	0.01
18.50	4.44	3.34	0.00
19.00	4.49	3.39	0.00
19.50	4.54	3.43	0.00
20.00	4.58	3.48	0.00
20.50	4.63	3.52	0.00
21.00	4.67	3.56	0.00
21.50	4.71	3.60	0.00
22.00	4.75	3.64	0.00
22.50	4.79	3.68	0.00
23.00	<b>4.83</b>	<b>3.71</b>	0.00

**Summary for Pond 2P: ROOF INFILTRATION**

Inflow Area = 0.052 ac, 78.07% Impervious, Inflow Depth > 3.71" for 10-Year event  
 Inflow = 0.22 cfs @ 12.11 hrs, Volume= 0.016 af  
 Outflow = 0.22 cfs @ 12.12 hrs, Volume= 0.015 af, Atten= 2%, Lag= 0.6 min  
 Discarded = 0.00 cfs @ 6.76 hrs, Volume= 0.004 af  
 Primary = 0.22 cfs @ 12.12 hrs, Volume= 0.011 af

Routing by Stor-Ind method, Time Span= 1.00-23.00 hrs, dt= 0.01 hrs  
 Peak Elev= 3.29' @ 12.12 hrs Surf.Area= 0.002 ac Storage= 0.002 af

Plug-Flow detention time= 56.8 min calculated for 0.015 af (93% of inflow)  
 Center-of-Mass det. time= 18.9 min ( 809.3 - 790.4 )

Volume	Invert	Avail.Storage	Storage Description
#1A	2.00'	0.002 af	<b>6.25'W x 16.68'L x 3.50'H Field A</b> 0.008 af Overall - 0.002 af Embedded = 0.006 af x 30.0% Voids
#2A	2.50'	0.002 af	<b>ADS_StormTech SC-740 x 2 Inside #1</b> Effective Size= 44.6"W x 30.0"H => 6.45 sf x 7.12'L = 45.9 cf Overall Size= 51.0"W x 30.0"H x 7.56'L with 0.44' Overlap Row Length Adjustment= +0.44' x 6.45 sf x 1 rows
		0.004 af	Total Available Storage

Storage Group A created with Chamber Wizard

Device	Routing	Invert	Outlet Devices
#1	Discarded	2.00'	<b>1.020 in/hr Exfiltration over Surface area</b>
#2	Primary	3.00'	<b>6.0" Round Culvert</b> L= 40.0' Ke= 0.500 Inlet / Outlet Invert= 3.00' / 2.50' S= 0.0125 ' / ' Cc= 0.900 n= 0.010 PVC, smooth interior, Flow Area= 0.20 sf

**Discarded OutFlow** Max=0.00 cfs @ 6.76 hrs HW=2.04' (Free Discharge)  
 ↗1=Exfiltration (Exfiltration Controls 0.00 cfs)

**Primary OutFlow** Max=0.22 cfs @ 12.12 hrs HW=3.29' (Free Discharge)  
 ↗2=Culvert (Inlet Controls 0.22 cfs @ 1.83 fps)

**Pond 2P: ROOF INFILTRATION - Chamber Wizard Field A**

**Chamber Model = ADS\_StormTech SC-740 (ADS StormTech® SC-740)**

Effective Size= 44.6"W x 30.0"H => 6.45 sf x 7.12'L = 45.9 cf

Overall Size= 51.0"W x 30.0"H x 7.56'L with 0.44' Overlap

Row Length Adjustment= +0.44' x 6.45 sf x 1 rows

2 Chambers/Row x 7.12' Long +0.44' Row Adjustment = 14.68' Row Length +12.0" End Stone x 2 = 16.68' Base Length

1 Rows x 51.0" Wide + 12.0" Side Stone x 2 = 6.25' Base Width

6.0" Base + 30.0" Chamber Height + 6.0" Cover = 3.50' Field Height

2 Chambers x 45.9 cf +0.44' Row Adjustment x 6.45 sf x 1 Rows = 94.7 cf Chamber Storage

364.9 cf Field - 94.7 cf Chambers = 270.2 cf Stone x 30.0% Voids = 81.0 cf Stone Storage

Chamber Storage + Stone Storage = 175.8 cf = 0.004 af

Overall Storage Efficiency = 48.2%

2 Chambers

13.5 cy Field

10.0 cy Stone

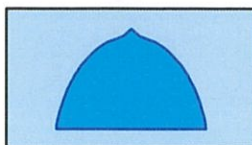
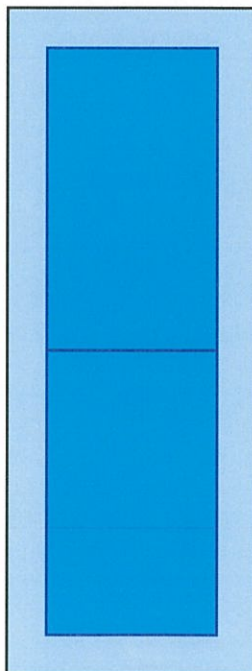



### Pond 2P: ROOF INFILTRATION

Hydrograph

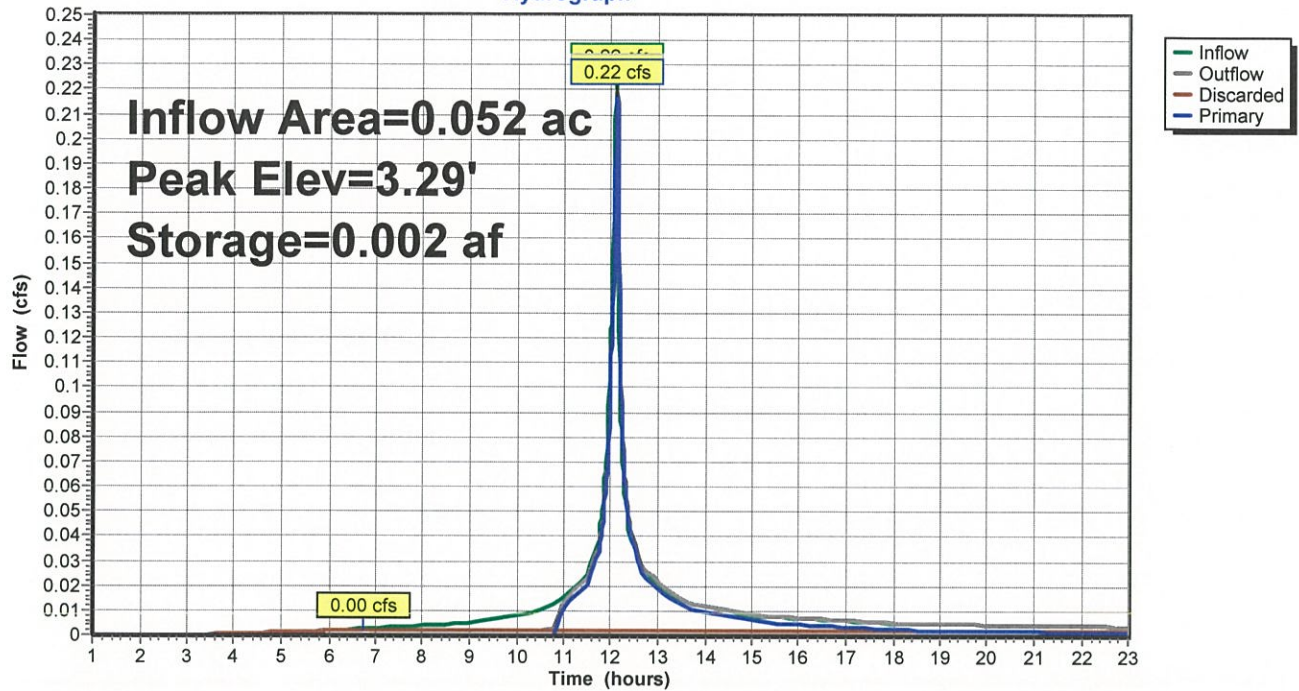

## Hydrograph for Pond 2P: ROOF INFILTRATION

Time (hours)	Inflow (cfs)	Storage (acre-feet)	Elevation (feet)	Outflow (cfs)	Discarded (cfs)	Primary (cfs)
1.00	0.00	0.000	2.00	0.00	0.00	0.00
1.50	0.00	0.000	2.00	0.00	0.00	0.00
2.00	0.00	0.000	2.00	0.00	0.00	0.00
2.50	0.00	0.000	2.00	0.00	0.00	0.00
3.00	0.00	0.000	2.00	0.00	0.00	0.00
3.50	0.00	0.000	2.00	0.00	0.00	0.00
4.00	0.00	0.000	2.01	0.00	0.00	0.00
4.50	0.00	0.000	2.01	0.00	0.00	0.00
5.00	0.00	0.000	2.02	0.00	0.00	0.00
5.50	0.00	0.000	2.02	0.00	0.00	0.00
6.00	0.00	0.000	2.03	0.00	0.00	0.00
6.50	0.00	0.000	2.03	0.00	<b>0.00</b>	0.00
7.00	0.00	0.000	2.04	0.00	<b>0.00</b>	0.00
7.50	0.00	0.000	2.08	0.00	0.00	0.00
8.00	0.00	0.000	2.15	0.00	0.00	0.00
8.50	0.00	0.000	2.25	0.00	0.00	0.00
9.00	0.01	0.000	2.39	0.00	0.00	0.00
9.50	0.01	0.000	2.54	0.00	0.00	0.00
10.00	0.01	0.001	2.67	0.00	0.00	0.00
10.50	0.01	0.001	2.84	0.00	0.00	0.00
11.00	0.02	0.001	3.06	0.01	0.00	0.01
11.50	0.02	0.001	3.08	0.02	0.00	0.02
12.00	<b>0.12</b>	<b>0.001</b>	<b>3.20</b>	<b>0.12</b>	0.00	<b>0.11</b>
12.50	<b>0.04</b>	<b>0.001</b>	<b>3.11</b>	<b>0.04</b>	0.00	<b>0.04</b>
13.00	0.02	0.001	3.08	0.02	0.00	0.02
13.50	0.01	0.001	3.06	0.01	0.00	0.01
14.00	0.01	0.001	3.05	0.01	0.00	0.01
14.50	0.01	0.001	3.05	0.01	0.00	0.01
15.00	0.01	0.001	3.04	0.01	0.00	0.01
15.50	0.01	0.001	3.04	0.01	0.00	0.01
16.00	0.01	0.001	3.04	0.01	0.00	0.00
16.50	0.01	0.001	3.03	0.01	0.00	0.00
17.00	0.01	0.001	3.03	0.01	0.00	0.00
17.50	0.01	0.001	3.03	0.01	0.00	0.00
18.00	0.01	0.001	3.03	0.01	0.00	0.00
18.50	0.00	0.001	3.02	0.00	0.00	0.00
19.00	0.00	0.001	3.02	0.00	0.00	0.00
19.50	0.00	0.001	3.02	0.00	0.00	0.00
20.00	0.00	0.001	3.02	0.00	0.00	0.00
20.50	0.00	0.001	3.02	0.00	0.00	0.00
21.00	0.00	0.001	3.02	0.00	0.00	0.00
21.50	0.00	0.001	3.02	0.00	0.00	0.00
22.00	0.00	0.001	3.02	0.00	0.00	0.00
22.50	0.00	0.001	3.02	0.00	0.00	0.00
23.00	0.00	0.001	3.02	0.00	0.00	0.00

**Summary for Subcatchment 3S: 64-66 GOVE-PROPOSED**

Runoff = 0.29 cfs @ 12.11 hrs, Volume= 0.022 af, Depth> 4.94"

Runoff by SCS TR-20 method, UH=SCS, Weighted-CN, Time Span= 1.00-23.00 hrs, dt= 0.01 hrs  
NRCC 24-hr D 25-Year Rainfall=6.19"

Area (sf)	CN	Description
1,780	98	Roofs, HSG B
500	61	>75% Grass cover, Good, HSG B
2,280	90	Weighted Average
500		21.93% Pervious Area
1,780		78.07% Impervious Area

Tc (min)	Length (feet)	Slope (ft/ft)	Velocity (ft/sec)	Capacity (cfs)	Description
4.0	50		0.21		Direct Entry, 64-66 GOVE

**Subcatchment 3S: 64-66 GOVE-PROPOSED**

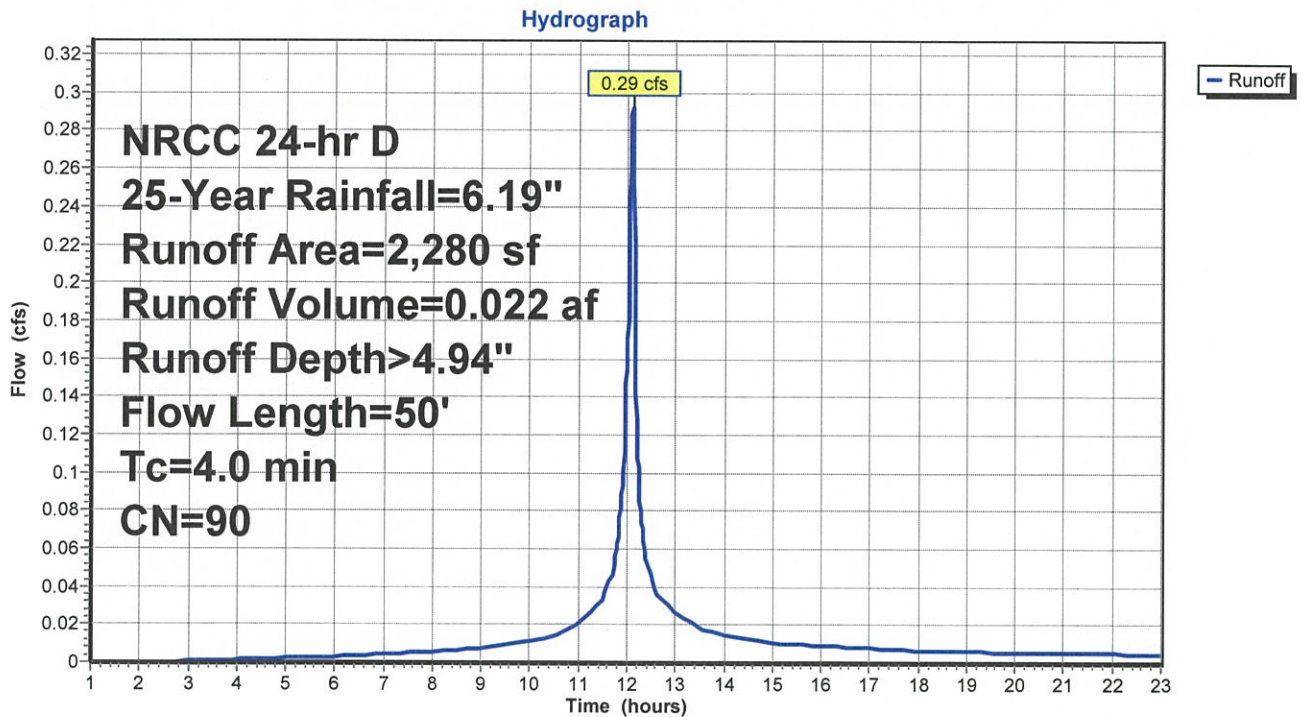

## Hydrograph for Subcatchment 3S: 64-66 GOVE-PROPOSED

Time (hours)	Precip. (inches)	Excess (inches)	Runoff (cfs)
1.00	0.09	0.00	0.00
1.50	0.14	0.00	0.00
2.00	0.19	0.00	0.00
2.50	0.24	0.00	0.00
3.00	0.29	0.00	0.00
3.50	0.34	0.01	0.00
4.00	0.40	0.02	0.00
4.50	0.46	0.04	0.00
5.00	0.51	0.06	0.00
5.50	0.58	0.09	0.00
6.00	0.64	0.11	0.00
6.50	0.70	0.15	0.00
7.00	0.78	0.19	0.00
7.50	0.86	0.23	0.01
8.00	0.94	0.28	0.01
8.50	1.04	0.34	0.01
9.00	1.14	0.41	0.01
9.50	1.25	0.49	0.01
10.00	1.39	0.60	0.01
10.50	1.55	0.72	0.01
11.00	1.76	0.89	0.02
11.50	2.07	1.16	0.03
12.00	2.97	1.95	<b>0.16</b>
12.50	4.12	3.03	<b>0.05</b>
13.00	4.43	3.33	0.03
13.50	4.64	3.53	0.02
14.00	4.80	3.69	0.02
14.50	4.94	3.82	0.01
15.00	5.05	3.93	0.01
15.50	5.15	4.02	0.01
16.00	5.25	4.11	0.01
16.50	5.33	4.20	0.01
17.00	5.41	4.28	0.01
17.50	5.49	4.35	0.01
18.00	5.55	4.41	0.01
18.50	5.61	4.47	0.01
19.00	5.68	4.53	0.01
19.50	5.73	4.59	0.01
20.00	5.79	4.64	0.01
20.50	5.85	4.70	0.01
21.00	5.90	4.75	0.01
21.50	5.95	4.80	0.01
22.00	6.00	4.85	0.01
22.50	6.05	4.90	0.00
23.00	<b>6.10</b>	<b>4.94</b>	0.00

**Summary for Pond 2P: ROOF INFILTRATION**

Inflow Area = 0.052 ac, 78.07% Impervious, Inflow Depth > 4.94" for 25-Year event  
 Inflow = 0.29 cfs @ 12.11 hrs, Volume= 0.022 af  
 Outflow = 0.29 cfs @ 12.12 hrs, Volume= 0.020 af, Atten= 2%, Lag= 0.6 min  
 Discarded = 0.00 cfs @ 5.33 hrs, Volume= 0.004 af  
 Primary = 0.29 cfs @ 12.12 hrs, Volume= 0.016 af

Routing by Stor-Ind method, Time Span= 1.00-23.00 hrs, dt= 0.01 hrs  
 Peak Elev= 3.34' @ 12.12 hrs Surf.Area= 0.002 ac Storage= 0.002 af

Plug-Flow detention time= 48.0 min calculated for 0.020 af (94% of inflow)  
 Center-of-Mass det. time= 18.0 min ( 798.9 - 780.8 )

Volume	Invert	Avail.Storage	Storage Description
#1A	2.00'	0.002 af	<b>6.25'W x 16.68'L x 3.50'H Field A</b> 0.008 af Overall - 0.002 af Embedded = 0.006 af x 30.0% Voids
#2A	2.50'	0.002 af	<b>ADS_StormTech SC-740 x 2 Inside #1</b> Effective Size= 44.6"W x 30.0"H => 6.45 sf x 7.12'L = 45.9 cf Overall Size= 51.0"W x 30.0"H x 7.56'L with 0.44' Overlap Row Length Adjustment= +0.44' x 6.45 sf x 1 rows
		0.004 af	Total Available Storage

Storage Group A created with Chamber Wizard

Device	Routing	Invert	Outlet Devices
#1	Discarded	2.00'	<b>1.020 in/hr Exfiltration over Surface area</b>
#2	Primary	3.00'	<b>6.0" Round Culvert L= 40.0' Ke= 0.500</b> Inlet / Outlet Invert= 3.00' / 2.50' S= 0.0125 '/ Cc= 0.900 n= 0.010 PVC, smooth interior, Flow Area= 0.20 sf

**Discarded OutFlow** Max=0.00 cfs @ 5.33 hrs HW=2.04' (Free Discharge)  
 ↑1=Exfiltration (Exfiltration Controls 0.00 cfs)

**Primary OutFlow** Max=0.29 cfs @ 12.12 hrs HW=3.34' (Free Discharge)  
 ↑2=Culvert (Inlet Controls 0.29 cfs @ 1.99 fps)

**Pond 2P: ROOF INFILTRATION - Chamber Wizard Field A**

**Chamber Model = ADS\_StormTech SC-740 (ADS StormTech® SC-740)**

Effective Size= 44.6"W x 30.0"H => 6.45 sf x 7.12'L = 45.9 cf

Overall Size= 51.0"W x 30.0"H x 7.56'L with 0.44' Overlap

Row Length Adjustment= +0.44' x 6.45 sf x 1 rows

2 Chambers/Row x 7.12' Long +0.44' Row Adjustment = 14.68' Row Length +12.0" End Stone x 2 = 16.68' Base Length

1 Rows x 51.0" Wide + 12.0" Side Stone x 2 = 6.25' Base Width

6.0" Base + 30.0" Chamber Height + 6.0" Cover = 3.50' Field Height

2 Chambers x 45.9 cf +0.44' Row Adjustment x 6.45 sf x 1 Rows = 94.7 cf Chamber Storage

364.9 cf Field - 94.7 cf Chambers = 270.2 cf Stone x 30.0% Voids = 81.0 cf Stone Storage

Chamber Storage + Stone Storage = 175.8 cf = 0.004 af

Overall Storage Efficiency = 48.2%

2 Chambers

13.5 cy Field

10.0 cy Stone

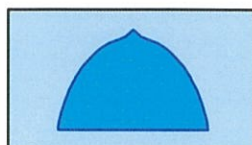
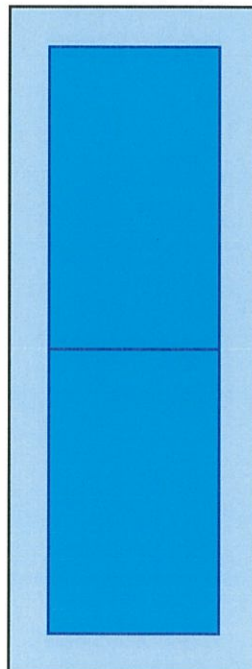

### Pond 2P: ROOF INFILTRATION

Hydrograph

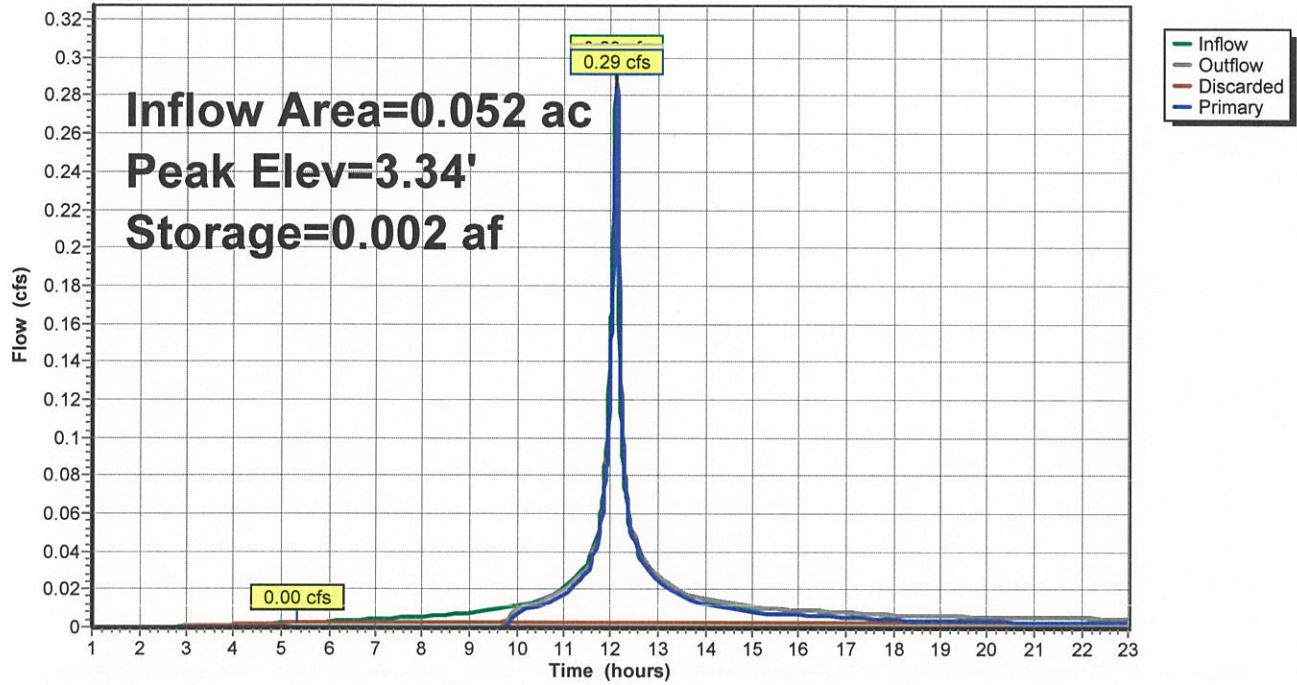

## Hydrograph for Pond 2P: ROOF INFILTRATION

Time (hours)	Inflow (cfs)	Storage (acre-feet)	Elevation (feet)	Outflow (cfs)	Discarded (cfs)	Primary (cfs)
1.00	0.00	0.000	2.00	0.00	0.00	0.00
1.50	0.00	0.000	2.00	0.00	0.00	0.00
2.00	0.00	0.000	2.00	0.00	0.00	0.00
2.50	0.00	0.000	2.00	0.00	0.00	0.00
3.00	0.00	0.000	2.01	0.00	0.00	0.00
3.50	0.00	0.000	2.01	0.00	0.00	0.00
4.00	0.00	0.000	2.02	0.00	0.00	0.00
4.50	0.00	0.000	2.03	0.00	0.00	0.00
5.00	0.00	0.000	2.03	0.00	<b>0.00</b>	0.00
5.50	0.00	0.000	2.04	0.00	<b>0.00</b>	0.00
6.00	0.00	0.000	2.06	0.00	0.00	0.00
6.50	0.00	0.000	2.12	0.00	0.00	0.00
7.00	0.00	0.000	2.21	0.00	0.00	0.00
7.50	0.01	0.000	2.34	0.00	0.00	0.00
8.00	0.01	0.000	2.51	0.00	0.00	0.00
8.50	0.01	0.001	2.61	0.00	0.00	0.00
9.00	0.01	0.001	2.73	0.00	0.00	0.00
9.50	0.01	0.001	2.88	0.00	0.00	0.00
10.00	0.01	0.001	3.05	0.01	0.00	0.01
10.50	0.01	0.001	3.06	0.01	0.00	0.01
11.00	0.02	0.001	3.07	0.02	0.00	0.02
11.50	0.03	0.001	3.10	0.03	0.00	0.03
12.00	<b>0.16</b>	<b>0.002</b>	<b>3.24</b>	<b>0.15</b>	0.00	<b>0.15</b>
12.50	<b>0.05</b>	<b>0.001</b>	<b>3.12</b>	<b>0.05</b>	0.00	<b>0.05</b>
13.00	0.03	0.001	3.09	0.03	0.00	0.03
13.50	0.02	0.001	3.07	0.02	0.00	0.02
14.00	0.02	0.001	3.06	0.02	0.00	0.01
14.50	0.01	0.001	3.06	0.01	0.00	0.01
15.00	0.01	0.001	3.05	0.01	0.00	0.01
15.50	0.01	0.001	3.05	0.01	0.00	0.01
16.00	0.01	0.001	3.05	0.01	0.00	0.01
16.50	0.01	0.001	3.04	0.01	0.00	0.01
17.00	0.01	0.001	3.04	0.01	0.00	0.01
17.50	0.01	0.001	3.04	0.01	0.00	0.00
18.00	0.01	0.001	3.03	0.01	0.00	0.00
18.50	0.01	0.001	3.03	0.01	0.00	0.00
19.00	0.01	0.001	3.03	0.01	0.00	0.00
19.50	0.01	0.001	3.03	0.01	0.00	0.00
20.00	0.01	0.001	3.03	0.01	0.00	0.00
20.50	0.01	0.001	3.03	0.01	0.00	0.00
21.00	0.01	0.001	3.03	0.01	0.00	0.00
21.50	0.01	0.001	3.03	0.01	0.00	0.00
22.00	0.01	0.001	3.02	0.01	0.00	0.00
22.50	0.00	0.001	3.02	0.01	0.00	0.00
23.00	0.00	0.001	3.02	0.00	0.00	0.00



**Summary for Subcatchment 3S: 64-66 GOVE-PROPOSED**

Runoff = 0.43 cfs @ 12.11 hrs, Volume= 0.033 af, Depth> 7.49"

Runoff by SCS TR-20 method, UH=SCS, Weighted-CN, Time Span= 1.00-23.00 hrs, dt= 0.01 hrs  
NRCC 24-hr D 100-Year Rainfall=8.83"

Area (sf)	CN	Description
1,780	98	Roofs, HSG B
500	61	>75% Grass cover, Good, HSG B
2,280	90	Weighted Average
500		21.93% Pervious Area
1,780		78.07% Impervious Area

Tc (min)	Length (feet)	Slope (ft/ft)	Velocity (ft/sec)	Capacity (cfs)	Description
4.0	50		0.21		Direct Entry, 64-66 GOVE

**Subcatchment 3S: 64-66 GOVE-PROPOSED**

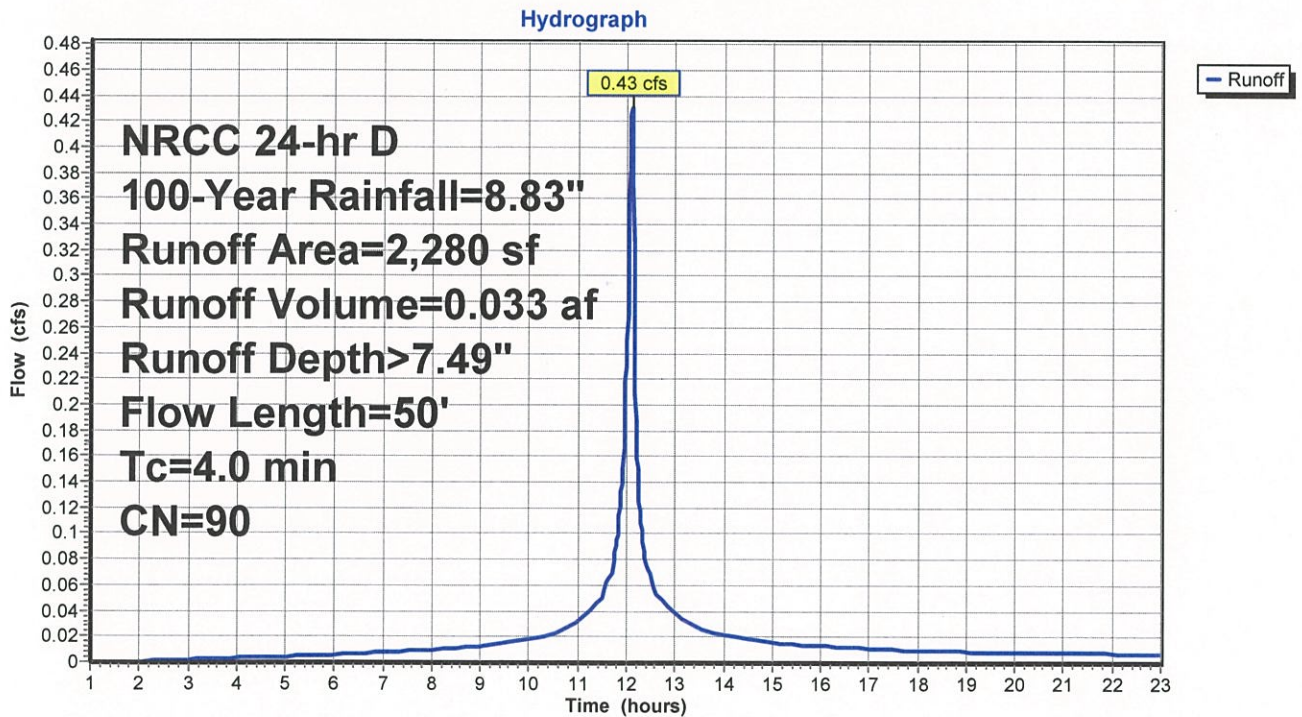

## Hydrograph for Subcatchment 3S: 64-66 GOVE-PROPOSED

Time (hours)	Precip. (inches)	Excess (inches)	Runoff (cfs)
1.00	0.13	0.00	0.00
1.50	0.20	0.00	0.00
2.00	0.27	0.00	0.00
2.50	0.34	0.01	0.00
3.00	0.41	0.03	0.00
3.50	0.49	0.05	0.00
4.00	0.57	0.08	0.00
4.50	0.65	0.12	0.00
5.00	0.73	0.16	0.00
5.50	0.82	0.21	0.01
6.00	0.91	0.26	0.01
6.50	1.00	0.32	0.01
7.00	1.11	0.39	0.01
7.50	1.22	0.47	0.01
8.00	1.35	0.57	0.01
8.50	1.48	0.67	0.01
9.00	1.62	0.78	0.01
9.50	1.78	0.91	0.02
10.00	1.98	1.08	0.02
10.50	2.21	1.27	0.02
11.00	2.51	1.54	0.03
11.50	2.96	1.95	0.05
12.00	4.23	3.14	<b>0.24</b>
12.50	5.87	4.72	<b>0.07</b>
13.00	6.32	5.16	0.04
13.50	6.62	5.46	0.03
14.00	6.85	5.68	0.02
14.50	7.05	5.87	0.02
15.00	7.21	6.03	0.02
15.50	7.35	6.17	0.01
16.00	7.48	6.30	0.01
16.50	7.61	6.42	0.01
17.00	7.72	6.53	0.01
17.50	7.83	6.63	0.01
18.00	7.92	6.73	0.01
18.50	8.01	6.81	0.01
19.00	8.10	6.90	0.01
19.50	8.18	6.98	0.01
20.00	8.26	7.06	0.01
20.50	8.34	7.14	0.01
21.00	8.42	7.22	0.01
21.50	8.49	7.29	0.01
22.00	8.56	7.36	0.01
22.50	8.63	7.43	0.01
23.00	<b>8.70</b>	<b>7.50</b>	0.01

**Summary for Pond 2P: ROOF INFILTRATION**

Inflow Area = 0.052 ac, 78.07% Impervious, Inflow Depth > 7.49" for 100-Year event  
 Inflow = 0.43 cfs @ 12.11 hrs, Volume= 0.033 af  
 Outflow = 0.42 cfs @ 12.12 hrs, Volume= 0.031 af, Atten= 2%, Lag= 0.6 min  
 Discarded = 0.00 cfs @ 3.39 hrs, Volume= 0.004 af  
 Primary = 0.42 cfs @ 12.12 hrs, Volume= 0.027 af

Routing by Stor-Ind method, Time Span= 1.00-23.00 hrs, dt= 0.01 hrs  
 Peak Elev= 3.45' @ 12.12 hrs Surf.Area= 0.002 ac Storage= 0.002 af

Plug-Flow detention time= 37.6 min calculated for 0.031 af (96% of inflow)  
 Center-of-Mass det. time= 16.5 min ( 784.3 - 767.7 )

Volume	Invert	Avail.Storage	Storage Description
#1A	2.00'	0.002 af	<b>6.25'W x 16.68'L x 3.50'H Field A</b> 0.008 af Overall - 0.002 af Embedded = 0.006 af x 30.0% Voids
#2A	2.50'	0.002 af	<b>ADS_StormTech SC-740 x 2 Inside #1</b> Effective Size= 44.6"W x 30.0"H => 6.45 sf x 7.12'L = 45.9 cf Overall Size= 51.0"W x 30.0"H x 7.56'L with 0.44' Overlap Row Length Adjustment= +0.44' x 6.45 sf x 1 rows
		0.004 af	Total Available Storage

Storage Group A created with Chamber Wizard

Device	Routing	Invert	Outlet Devices
#1	Discarded	2.00'	<b>1.020 in/hr Exfiltration over Surface area</b>
#2	Primary	3.00'	<b>6.0" Round Culvert L= 40.0' Ke= 0.500</b> Inlet / Outlet Invert= 3.00' / 2.50' S= 0.0125 '/ Cc= 0.900 n= 0.010 PVC, smooth interior, Flow Area= 0.20 sf

**Discarded OutFlow** Max=0.00 cfs @ 3.39 hrs HW=2.04' (Free Discharge)  
 ↳1=Exfiltration (Exfiltration Controls 0.00 cfs)

**Primary OutFlow** Max=0.42 cfs @ 12.12 hrs HW=3.45' (Free Discharge)  
 ↳2=Culvert (Inlet Controls 0.42 cfs @ 2.28 fps)

**Pond 2P: ROOF INFILTRATION - Chamber Wizard Field A**

**Chamber Model = ADS\_StormTech SC-740 (ADS StormTech® SC-740)**

Effective Size= 44.6"W x 30.0"H => 6.45 sf x 7.12'L = 45.9 cf

Overall Size= 51.0"W x 30.0"H x 7.56'L with 0.44' Overlap

Row Length Adjustment= +0.44' x 6.45 sf x 1 rows

2 Chambers/Row x 7.12' Long +0.44' Row Adjustment = 14.68' Row Length +12.0" End Stone x 2 = 16.68' Base Length

1 Rows x 51.0" Wide + 12.0" Side Stone x 2 = 6.25' Base Width

6.0" Base + 30.0" Chamber Height + 6.0" Cover = 3.50' Field Height

2 Chambers x 45.9 cf +0.44' Row Adjustment x 6.45 sf x 1 Rows = 94.7 cf Chamber Storage

364.9 cf Field - 94.7 cf Chambers = 270.2 cf Stone x 30.0% Voids = 81.0 cf Stone Storage

Chamber Storage + Stone Storage = 175.8 cf = 0.004 af

Overall Storage Efficiency = 48.2%

2 Chambers

13.5 cy Field

10.0 cy Stone

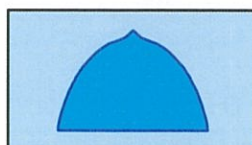
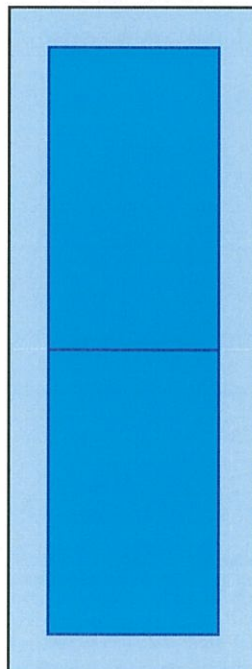

### Pond 2P: ROOF INFILTRATION

Hydrograph

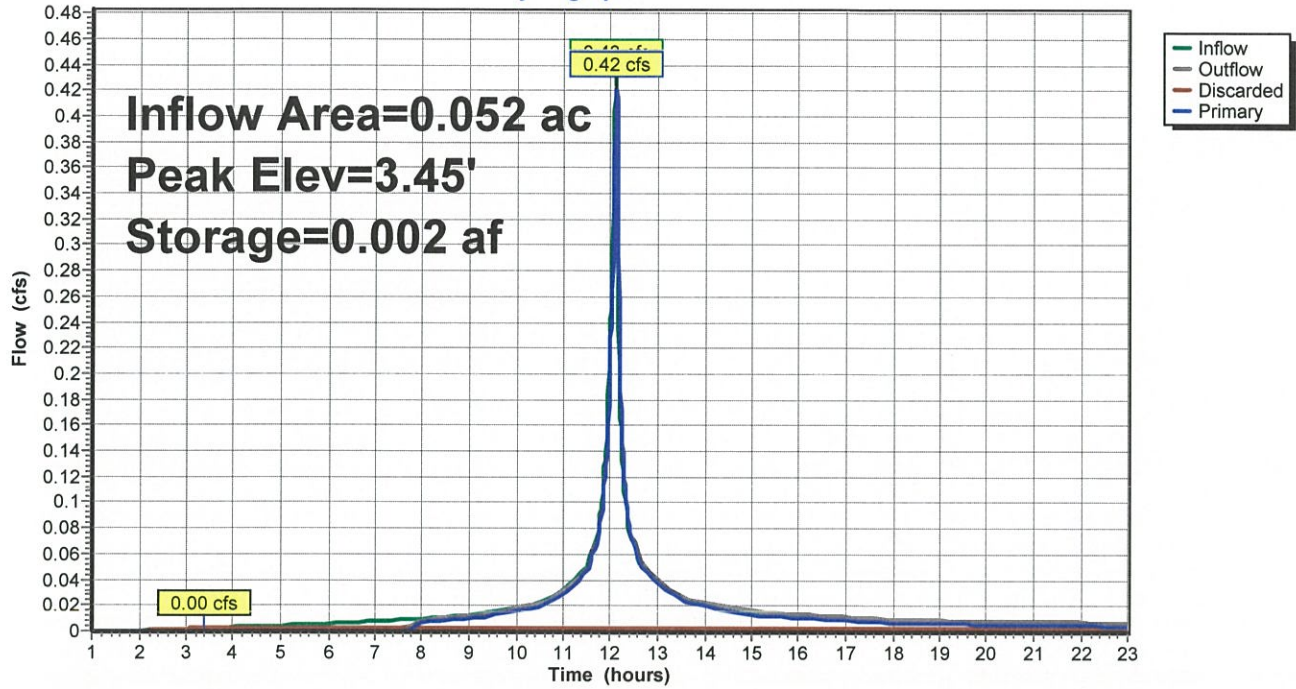

**Hydrograph for Pond 2P: ROOF INFILTRATION**

Time (hours)	Inflow (cfs)	Storage (acre-feet)	Elevation (feet)	Outflow (cfs)	Discarded (cfs)	Primary (cfs)
1.00	0.00	0.000	2.00	0.00	0.00	0.00
1.50	0.00	0.000	2.00	0.00	0.00	0.00
2.00	0.00	0.000	2.00	0.00	0.00	0.00
2.50	0.00	0.000	2.02	0.00	0.00	0.00
3.00	0.00	0.000	2.03	0.00	<b>0.00</b>	0.00
3.50	0.00	0.000	2.04	0.00	<b>0.00</b>	0.00
4.00	0.00	0.000	2.08	0.00	0.00	0.00
4.50	0.00	0.000	2.15	0.00	0.00	0.00
5.00	0.00	0.000	2.27	0.00	0.00	0.00
5.50	0.01	0.000	2.41	0.00	0.00	0.00
6.00	0.01	0.000	2.54	0.00	0.00	0.00
6.50	0.01	0.001	2.64	0.00	0.00	0.00
7.00	0.01	0.001	2.77	0.00	0.00	0.00
7.50	0.01	0.001	2.92	0.00	0.00	0.00
8.00	0.01	0.001	3.05	0.01	0.00	0.01
8.50	0.01	0.001	3.05	0.01	0.00	0.01
9.00	0.01	0.001	3.05	0.01	0.00	0.01
9.50	0.02	0.001	3.06	0.02	0.00	0.01
10.00	0.02	0.001	3.07	0.02	0.00	0.02
10.50	0.02	0.001	3.08	0.02	0.00	0.02
11.00	0.03	0.001	3.10	0.03	0.00	0.03
11.50	0.05	0.001	3.12	0.05	0.00	0.05
12.00	<b>0.24</b>	<b>0.002</b>	<b>3.30</b>	<b>0.23</b>	0.00	<b>0.23</b>
12.50	<b>0.07</b>	<b>0.001</b>	<b>3.15</b>	<b>0.07</b>	0.00	<b>0.07</b>
13.00	0.04	0.001	3.11	0.04	0.00	0.04
13.50	0.03	0.001	3.09	0.03	0.00	0.03
14.00	0.02	0.001	3.08	0.02	0.00	0.02
14.50	0.02	0.001	3.07	0.02	0.00	0.02
15.00	0.02	0.001	3.06	0.02	0.00	0.01
15.50	0.01	0.001	3.06	0.01	0.00	0.01
16.00	0.01	0.001	3.06	0.01	0.00	0.01
16.50	0.01	0.001	3.06	0.01	0.00	0.01
17.00	0.01	0.001	3.05	0.01	0.00	0.01
17.50	0.01	0.001	3.05	0.01	0.00	0.01
18.00	0.01	0.001	3.05	0.01	0.00	0.01
18.50	0.01	0.001	3.04	0.01	0.00	0.01
19.00	0.01	0.001	3.04	0.01	0.00	0.01
19.50	0.01	0.001	3.04	0.01	0.00	0.01
20.00	0.01	0.001	3.04	0.01	0.00	0.01
20.50	0.01	0.001	3.04	0.01	0.00	0.01
21.00	0.01	0.001	3.04	0.01	0.00	0.01
21.50	0.01	0.001	3.04	0.01	0.00	0.01
22.00	0.01	0.001	3.04	0.01	0.00	0.01
22.50	0.01	0.001	3.04	0.01	0.00	0.00
23.00	0.01	0.001	3.03	0.01	0.00	0.00

**STORMWATER  
TREATMENT &  
FACILITIES  
OPERATION &  
MAINTENANCE**

**APPENDIX**

## **LONG TERM POLLUTION PREVENTION PLAN**

- Good housekeeping practices will be standard operating procedures in order to maintain occupancy requirements including regular scheduled cleaning and maintenance
- Requirements for routine inspection and maintenance of stormwater BMP's are included in the O & M section of this report.
- No hazardous chemicals or petroleum products will be stored on site.
- A professional lawn and yard maintenance company will be hired for all exterior maintenance.
- No herbicides, high nitrogen fertilizers, or pesticides will be stored or used on the premises.
- Sanitary waste will be handled by connection to the municipal sewer.
- Trash removal will be by private hauler.
- Only non-toxic Calcium Chloride or similar snow melt materials will be used on parking lots and walks. Sand use will be professionally applied only as necessary under icy conditions.
- An Operation and Maintenance Manual and Pollution Prevention Plan will be prepared and made part of the training for all personnel (employees and contractors) who will have responsibility O & M and Pollution Prevention.
- A list of emergency contacts will be included in the O & M and Pollution Prevention Manual.



## O & M

### FACILITY

- MOW LAWNS (1)
- TRIM TREES & SHRUBS (1)
- INSPECT INFILTRATORS
- CLEAN SEDIMENT FROM INFILTRATORS (2)

### SCHEDULE

WEEKLY IN SEASON

SPRING & FALL

APRIL & NOVEMBER

AS NECESSARY - WITH  
SEDIMENT OR DEBRIS  
BUILD-UP

### RESPONSIBILITY

LANDSCAPE  
MAINTENANCE CO.

LANDSCAPE  
MAINTENANCE CO.

VACUUM PUMPING CO.

VACUUM PUMPING CO.

(1) LAWN CLIPPINGS TO  
BE MULCHED & LEFT  
ON LAWN TO  
REDUCE NEED FOR  
FERTILIZER EXCESS  
GRASS AND TREE &  
SHRUB CLIPPINGS  
TO BE DISPOSED OF  
AT A COMPOST  
FACILITY

(2) INFILTRATOR  
SEDIMENT TO BE  
DISPOSED OF AT A  
LANDFILL

(3) ADSORBED OIL TO  
BE DISPOSED OF BY  
A LIQUID WASTE  
HAULER

STORMTECH SC-740

INFILTRATORS

Provide an access port, man-way, and observation well to enable inspection of water levels within the system. Make the observation well pipe visible at grade (i.e., not buried).

**Maintenance**

Because subsurface structures are installed underground, they are extremely difficult to maintain. Inspect inlets at least twice a year. Remove any debris that might clog the system. Include mosquito controls in the Operation and Maintenance Plan.

**DRAINAGE CALCULATIONS**

ROOF AREA = 1870 S.F.  
 INFILTRATE (STORE) 1" OF RUNOFF  
 1/12 (1870 S.F.) = 156 CU. FT.  
 USE (2) STORMTECH SC-740 LEACH CHAMBERS - SEE DETAIL  
 45.9 CU. FT. WITH 1 FT. CRUSHED STONE AROUND EACH  
 45.9 CU. FT. x 2 = 91.8 CU. FT. CHAMBER VOLUME  
 VOLUME COMPUTATION EXTERIOR CRUSHED STONE  
 16.24 FT. x 3.5 FT. x 6.25 FT. = 355.3 CU. FT.  
 355.3 CU. FT. - 91.8 CU. FT. (CHAMBER VOLUME) = 263.5 CU. FT.  
 263.5 CU. FT. x 0.3 (VOIDS) = 79.1 CU. FT. VOLUME Voids STORAGE  
 91.8 CU. FT. CHAMBER VOLUME + 79.1 CU. FT. Voids = 170.9 CU. FT.  
 170.9 CU. FT. TOTAL STORAGE > 156 CU. FT. RUNOFF CALCULATION

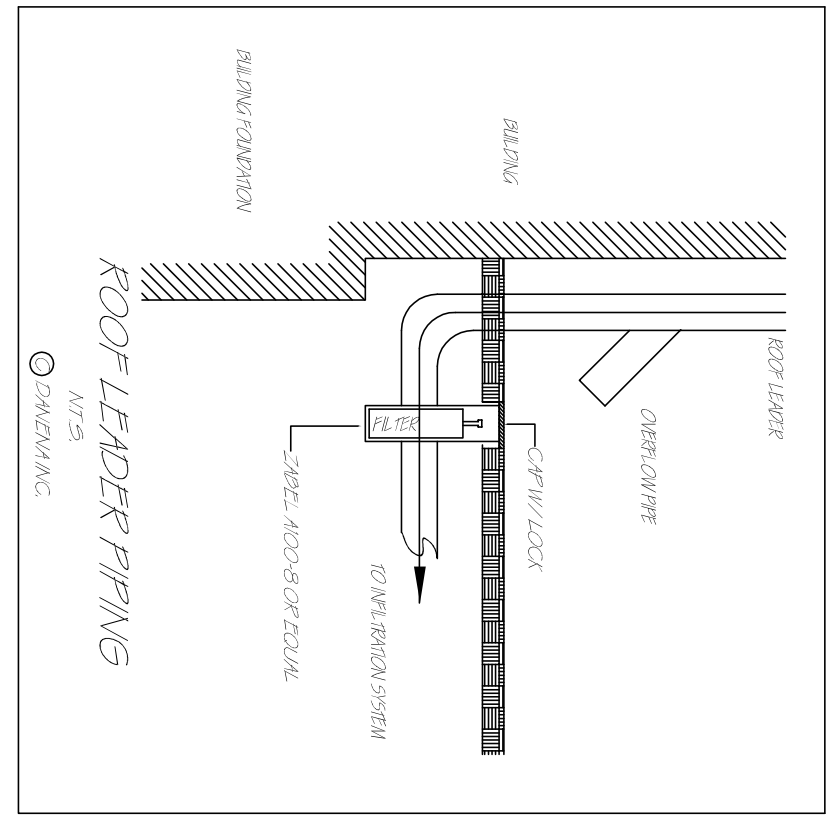
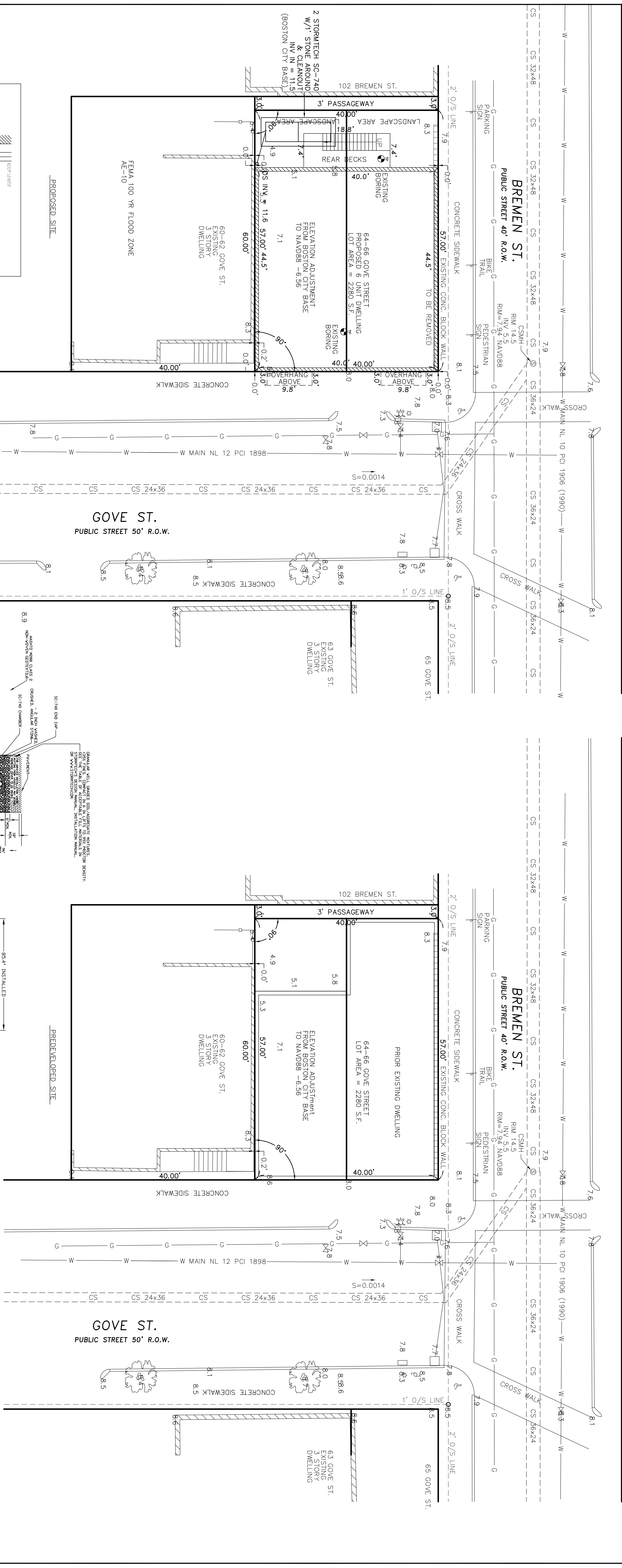
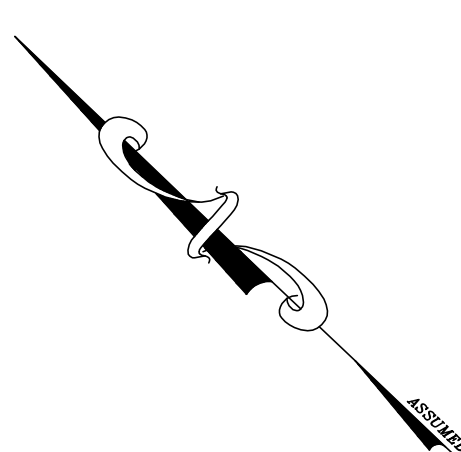

**ROOF DOWNSPOUT DETAIL**

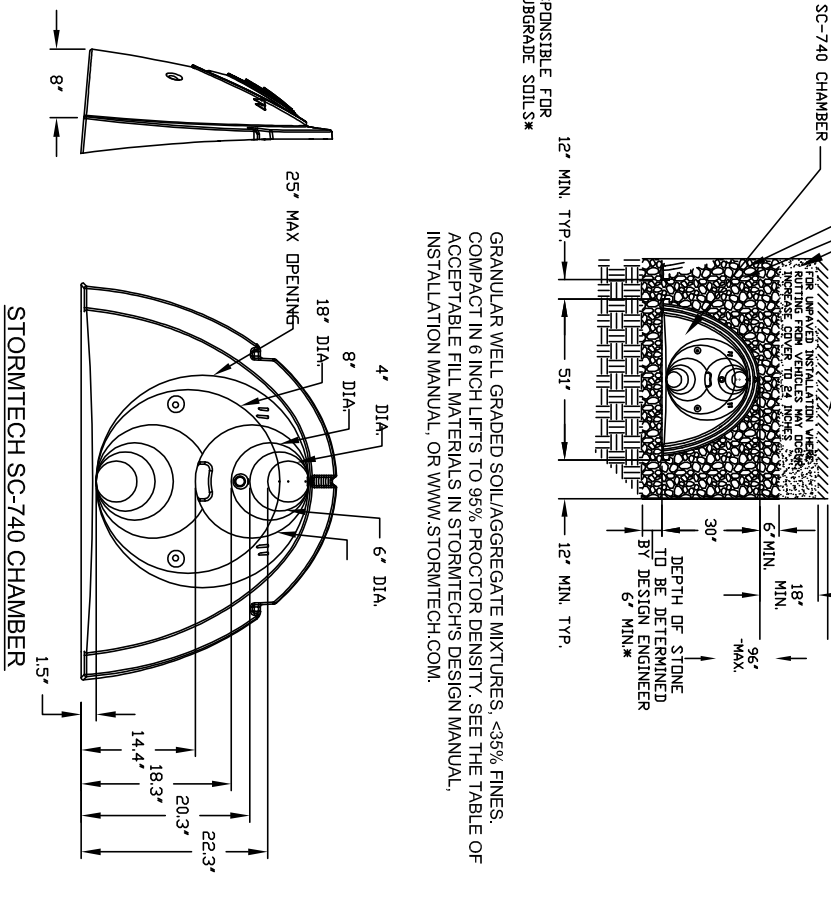
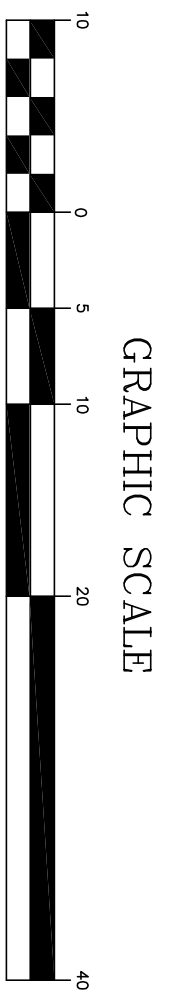

**INFILTRATOR DETAIL**

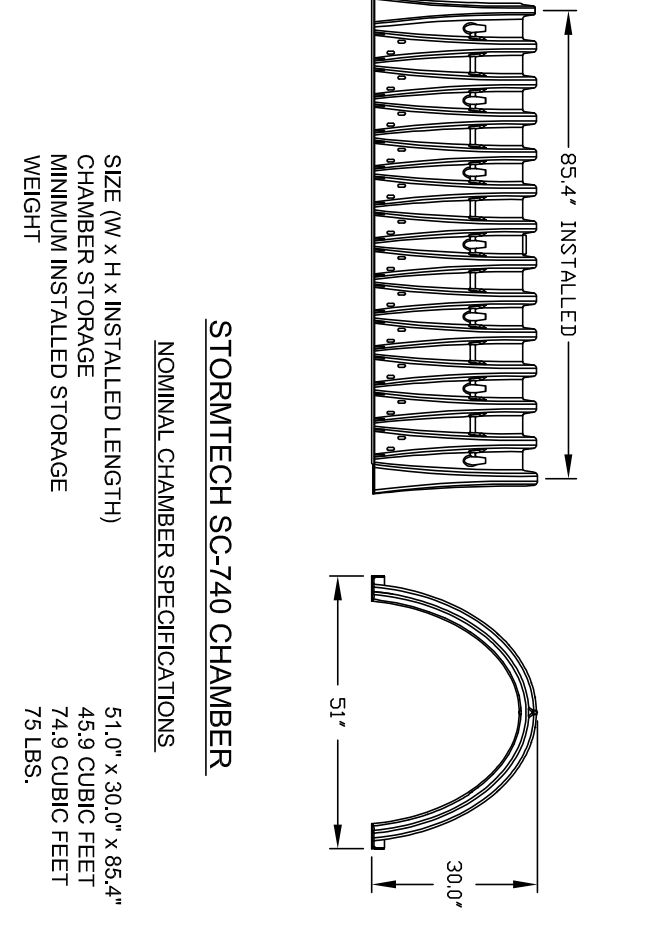

**CONSERVATION PLAN**  
**64-66 GOVE ST.**  
**EAST BOSTON, MA**  
 FOR  
**CHAN SING MING**

**CIVIL ENVIRONMENTAL CONSULTANTS**  
 8 OAK STREET PEABODY, MA 01960 978-531-1191  
 SHEET NO. 1 OF 1  
 DATE: 27/02/2018 JOB: 3516  
 DRAWN BY: L.J.B.