

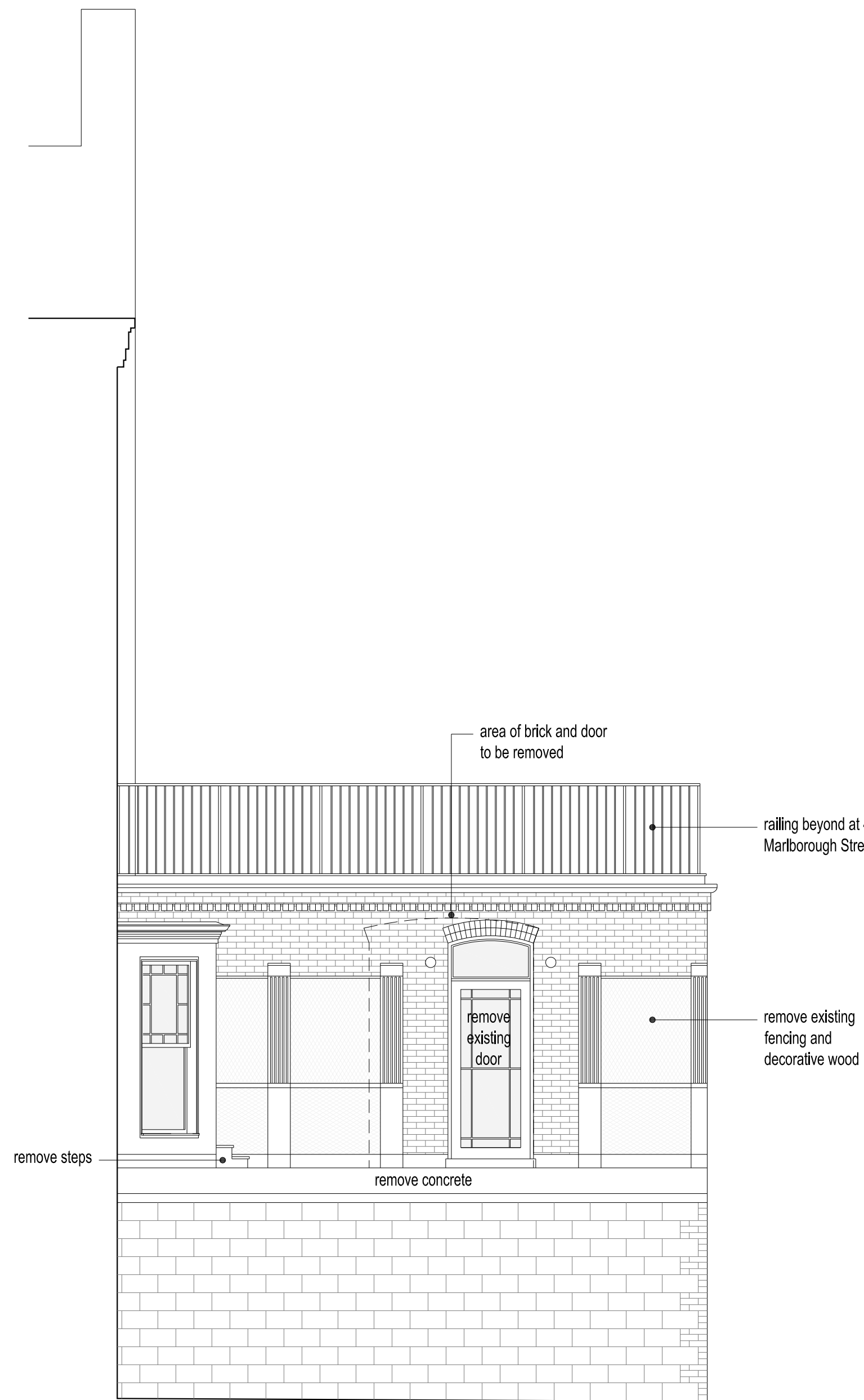

REAR ELEVATION SHOWING DEMOLITION



REAR ELEVATION SHOWING PROPOSED NEW DECK DOORS AND GARAGE



SIDE ELEVATION SHOWING DEMOLITION



SIDE ELEVATION SHOWING PROPOSED NEW DECK AND DOORS

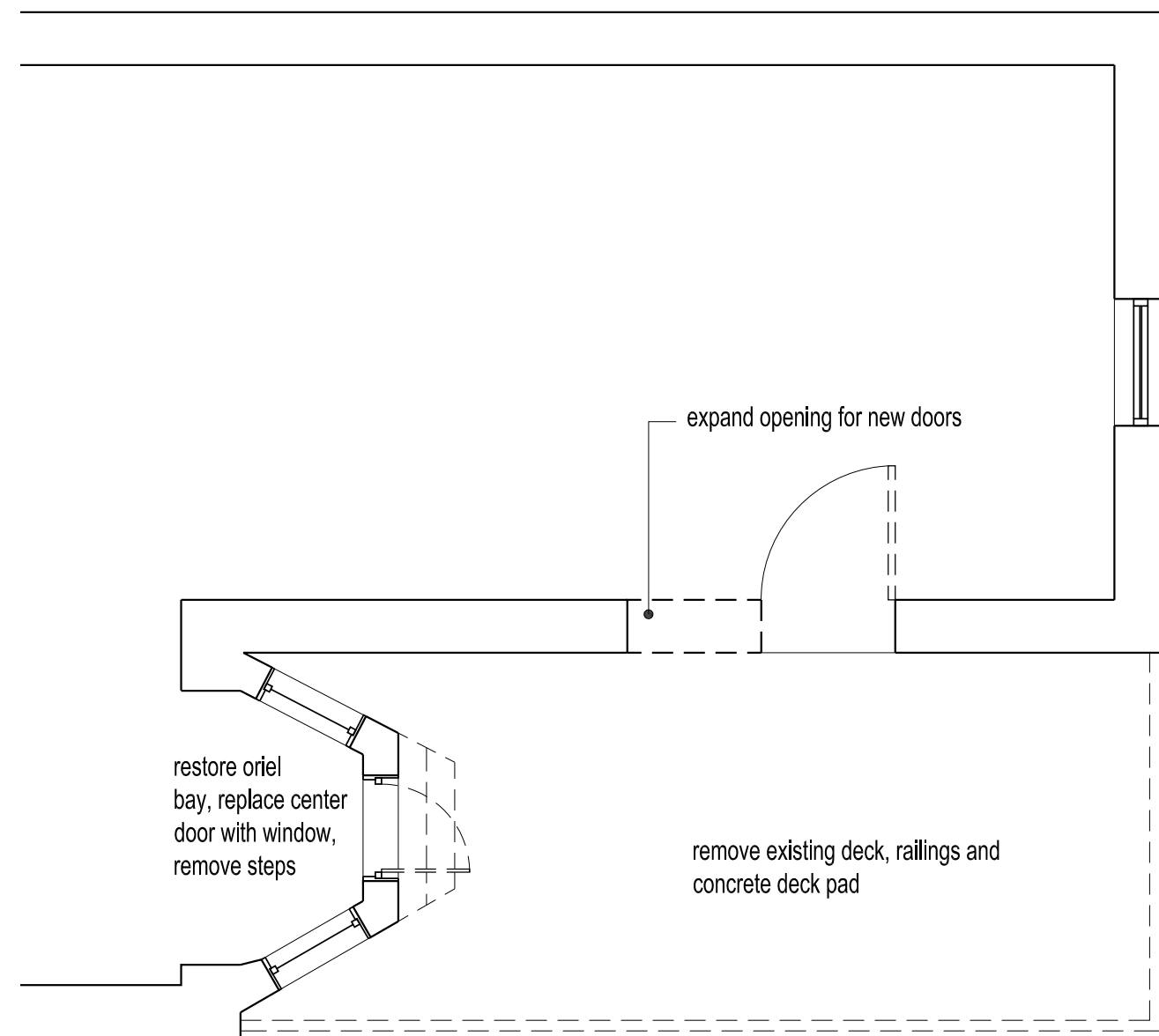

PARTIAL PLAN
SHOWING DEMOLITION

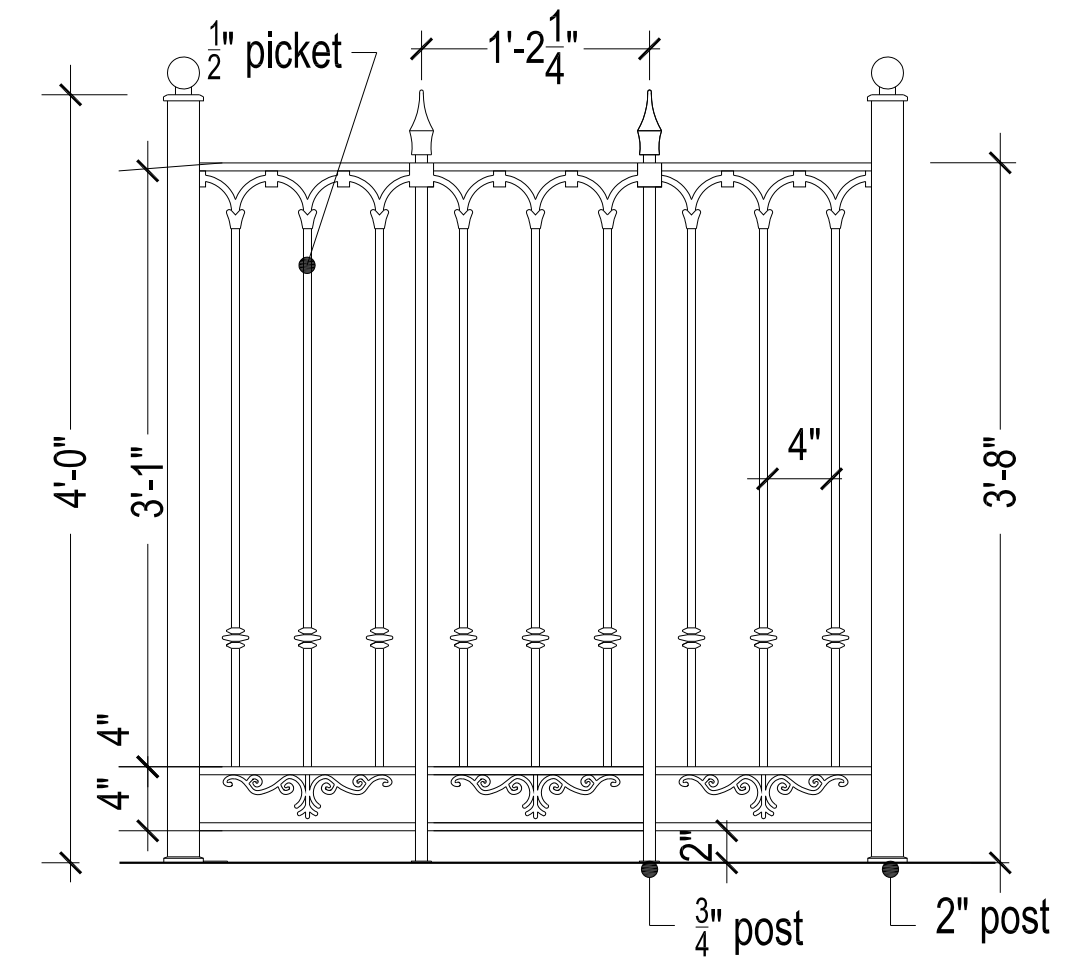

all iron elements, painted semi-gloss black

PROPOSED REAR DECK RAILINGS - 443 MARLBOROUGH STREET 1"=1'-0"

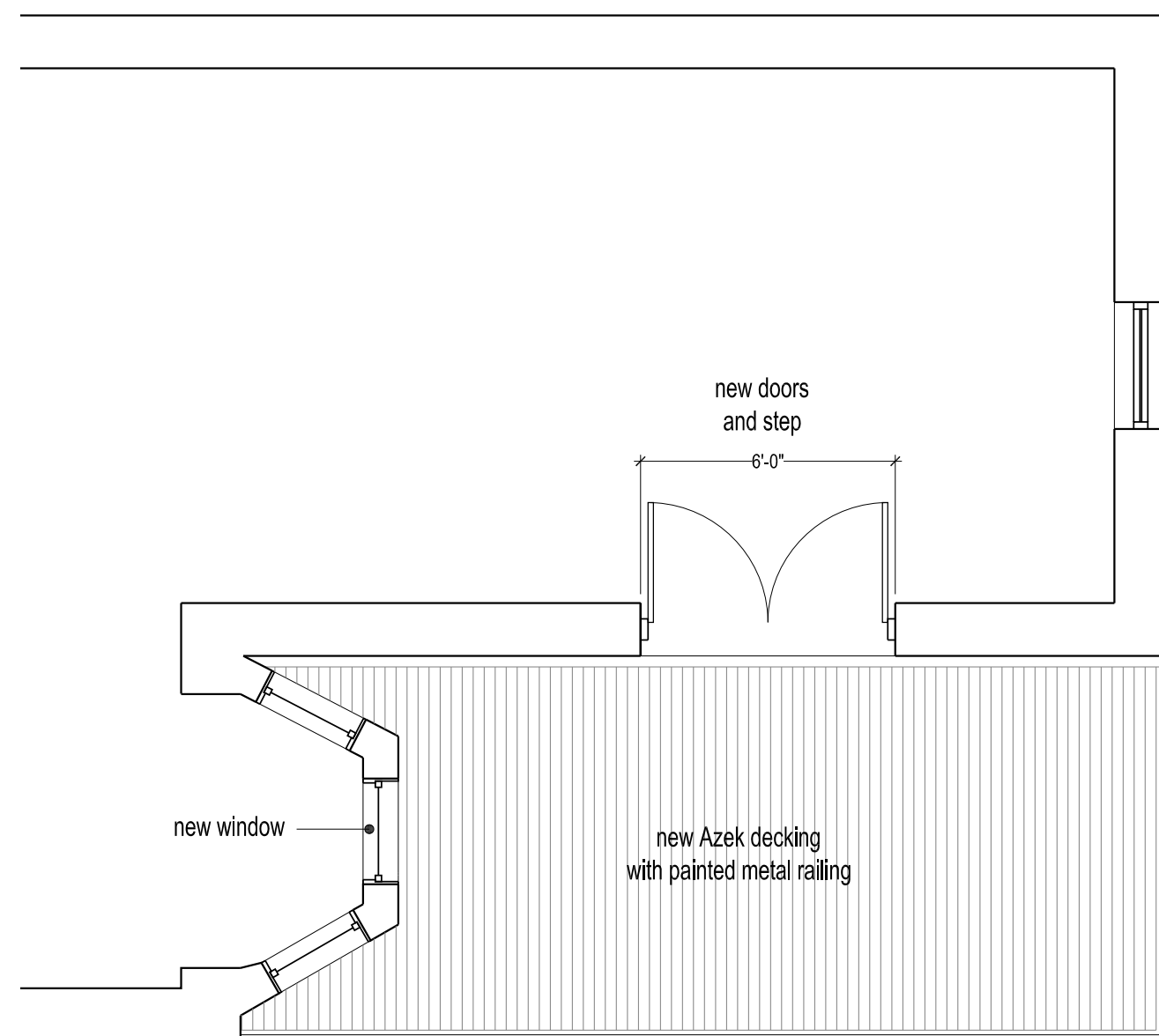

PARTIAL PLAN
SHOWING PROPOSED



RAILING AT REAR OF 300 BEACON STREET