

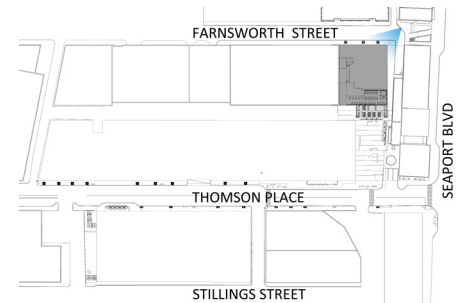

**TRILLIUM BREWING CO.**  
**47 FARNSWORTH STREET RENOVATION**  
*FORT POINT LANDMARKS SUBMISSION AUGUST 23, 2017*

# EXISTING CONDITIONS - THOMPSON PLACE PHOTOS

---



47 FARNSWORTH STREET RENOVATION  
Fort Point - Boston, MA

Whitlock Design Group  
681 Main Street, Suite 3-31  
Waltham, MA 02451  
(781) 647-8008  
www.whitlockdesigns.com



# EXISTING CONDITIONS - FARNSWORTH STREET PHOTOS

---



VIEW FROM SEAPORT BLVD

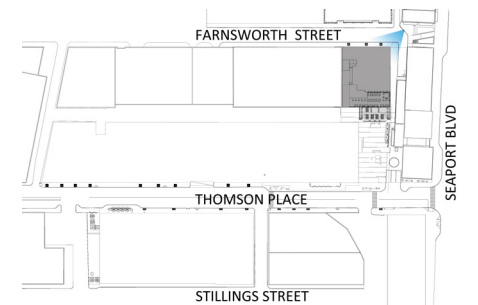

47 FARNSWORTH STREET RENOVATION  
Fort Point - Boston, MA

Whitlock Design Group  
681 Main Street, Suite 3-31  
Waltham, MA 02451  
(781) 647-8008  
www.whitlockdesigns.com



# EXISTING CONDITIONS - ROOFTOP PHOTOS

---



THOMPSON PLACE VIEW TO ROOF



# 47 FARNSWORTH - HISTORIC PHOTOS

---

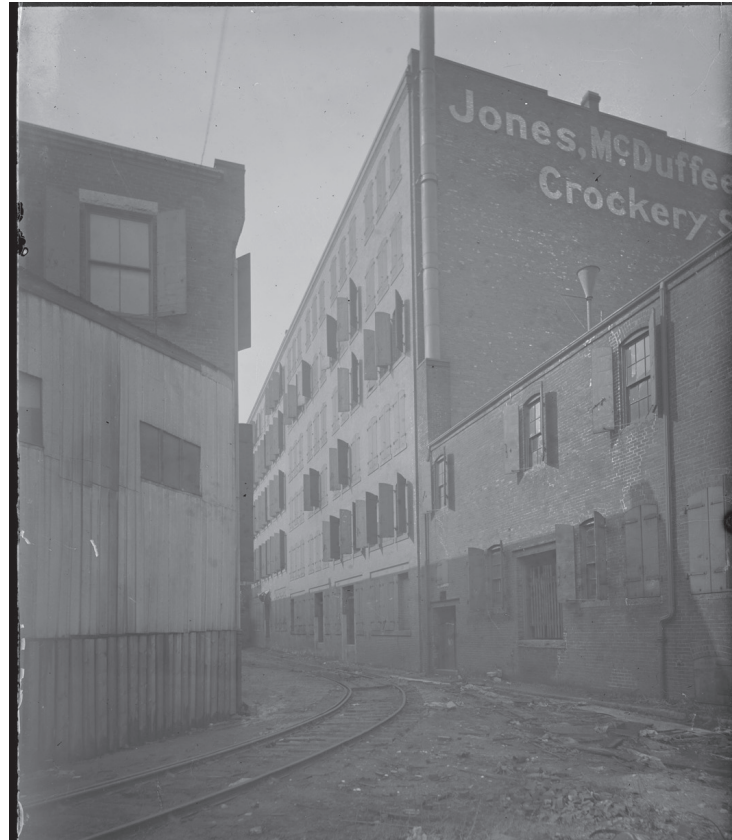

SOUTH FACADE



EAST FACADE



NORTH FACADE

# HISTORIC PHOTOS - AREA SIGNAGE

---



CORNER SIGNAGE



SIGNAGE BAND & SIGNAGE NEXT TO ENTRY DOOR



# HISTORIC PHOTOS - ROOFTOP SIGNAGE

---



BOSTON WHARF COMPANY



NECCO



PROVIDENCE BREWING



47 FARNSWORTH STREET RENOVATION  
Fort Point - Boston, MA

**Whitlock Design Group**  
681 Main Street, Suite 3-31  
Waltham, MA 02451  
(781) 647-8008  
[www.whitlockdesigns.com](http://www.whitlockdesigns.com)



# HISTORIC PHOTOS - BREWERIES

---



PABST BREWING



PROVIDENCE BREWING



ROCHESTER BREWING



47 FARNSWORTH STREET RENOVATION  
Fort Point - Boston, MA

**Whitlock Design Group**  
681 Main Street, Suite 3-31  
Waltham, MA 02451  
(781) 647-8008  
[www.whitlockdesigns.com](http://www.whitlockdesigns.com)





# HISTORIC PHOTOS & INSPIRATION - ROOF DECK

---



ROOF DECK PAVILION ATOP  
BOSTON WHARF COMPANY

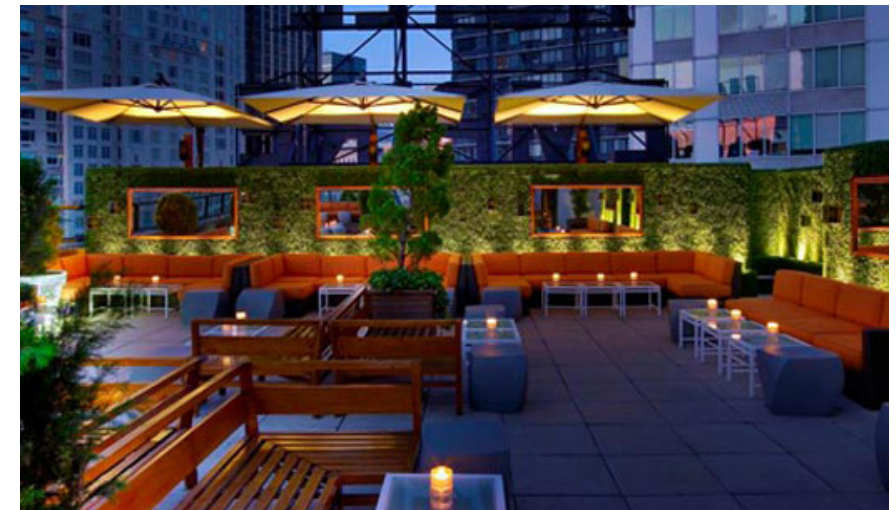

INSPIRATION

# EXISTING CONDITIONS - SITE PLAN

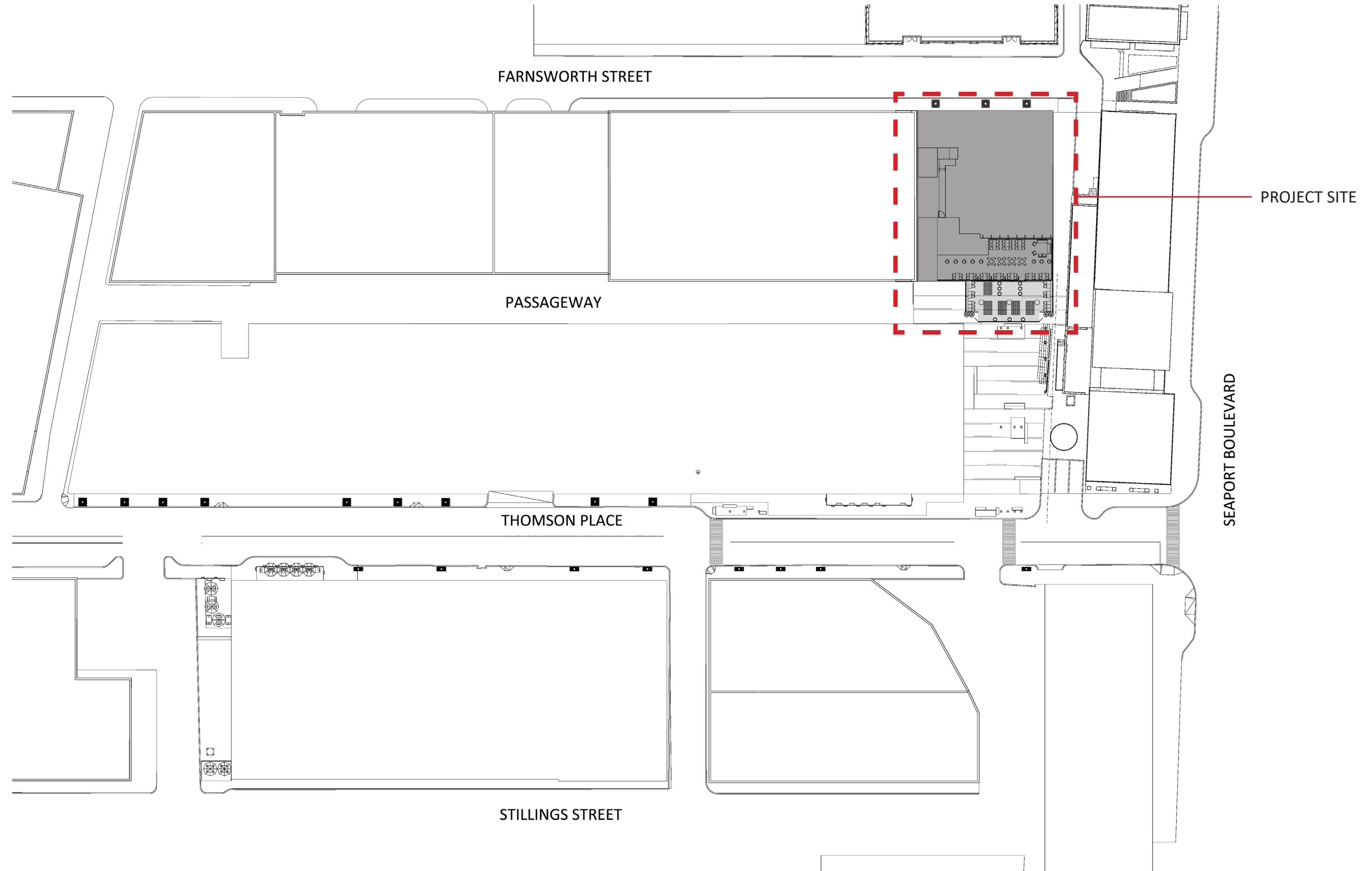

# EXTERIOR MODIFICATIONS - FIRST FLOOR PLAN

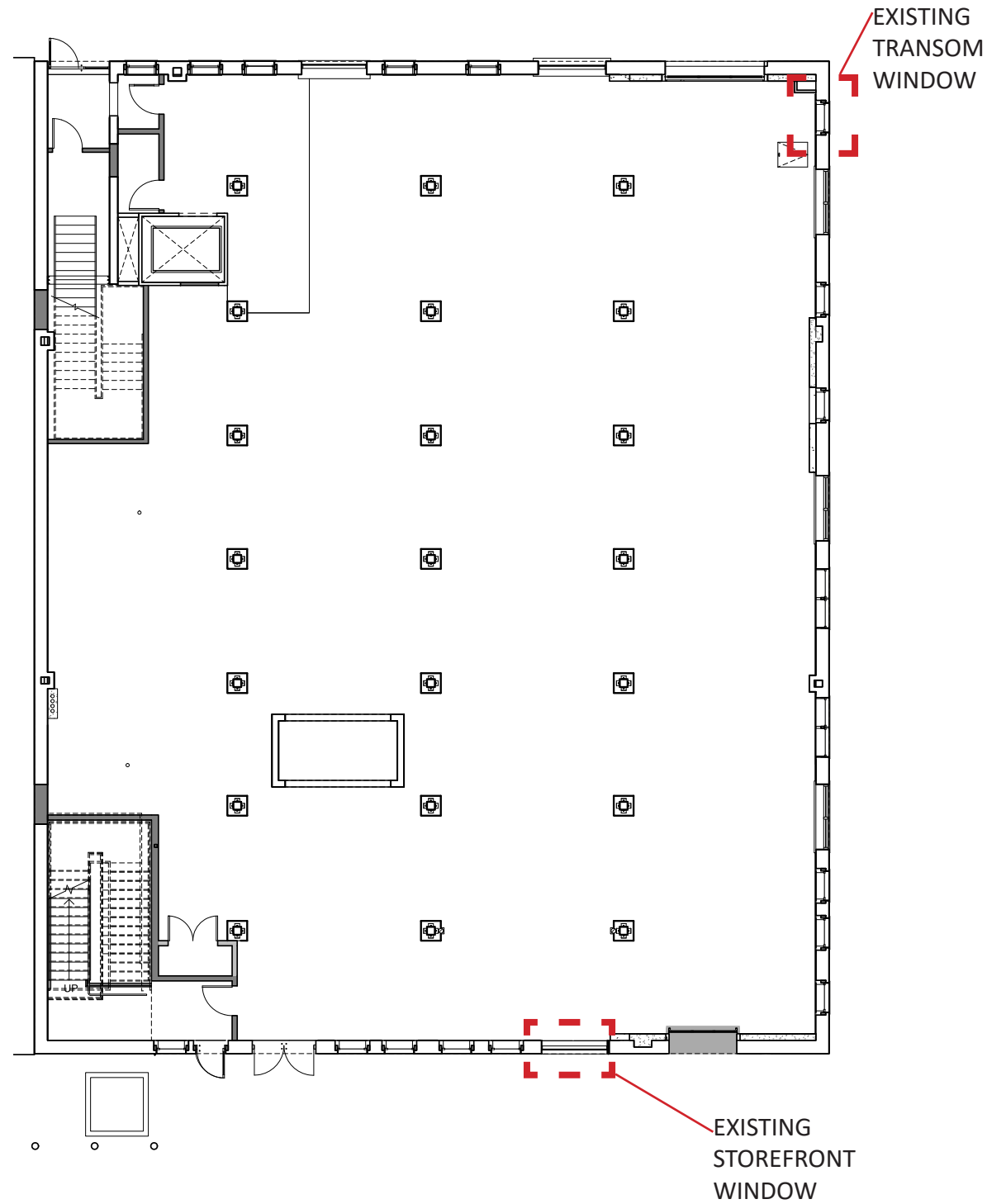

EXISTING CONDITIONS PLAN

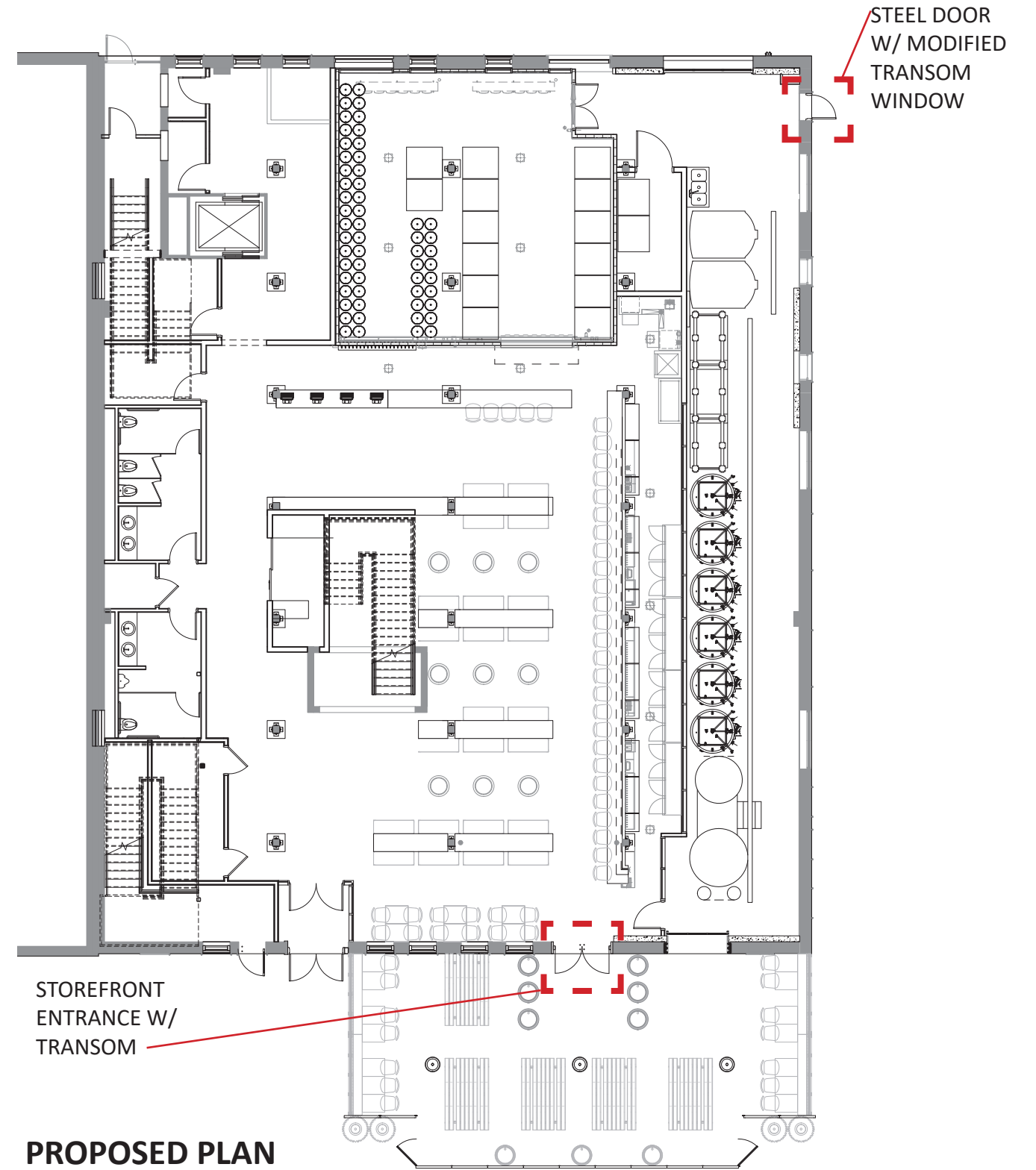

PROPOSED PLAN

# EXTERIOR MODIFICATIONS - ROOF DECK PLAN

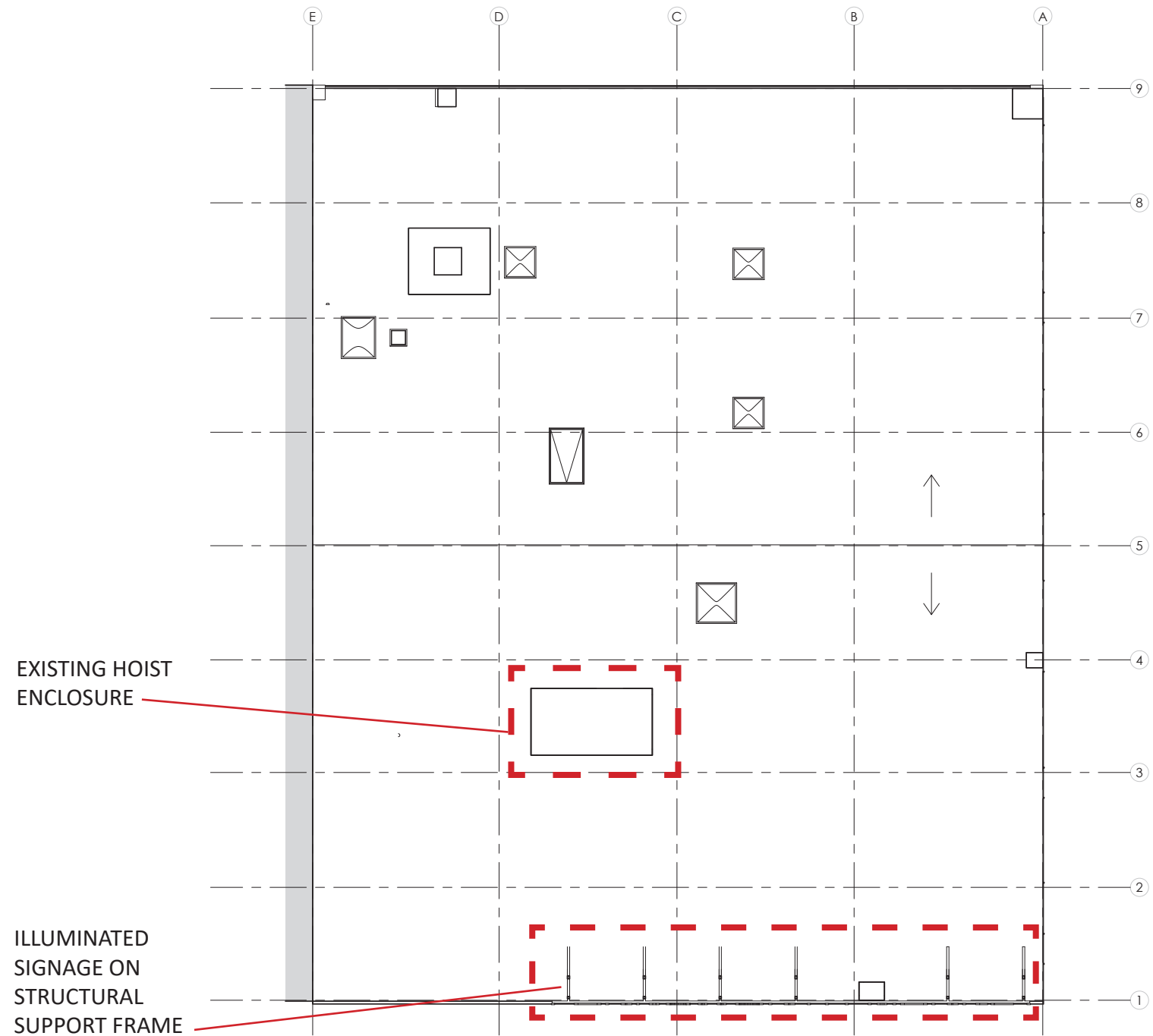

**EXISTING CONDITIONS PLAN**

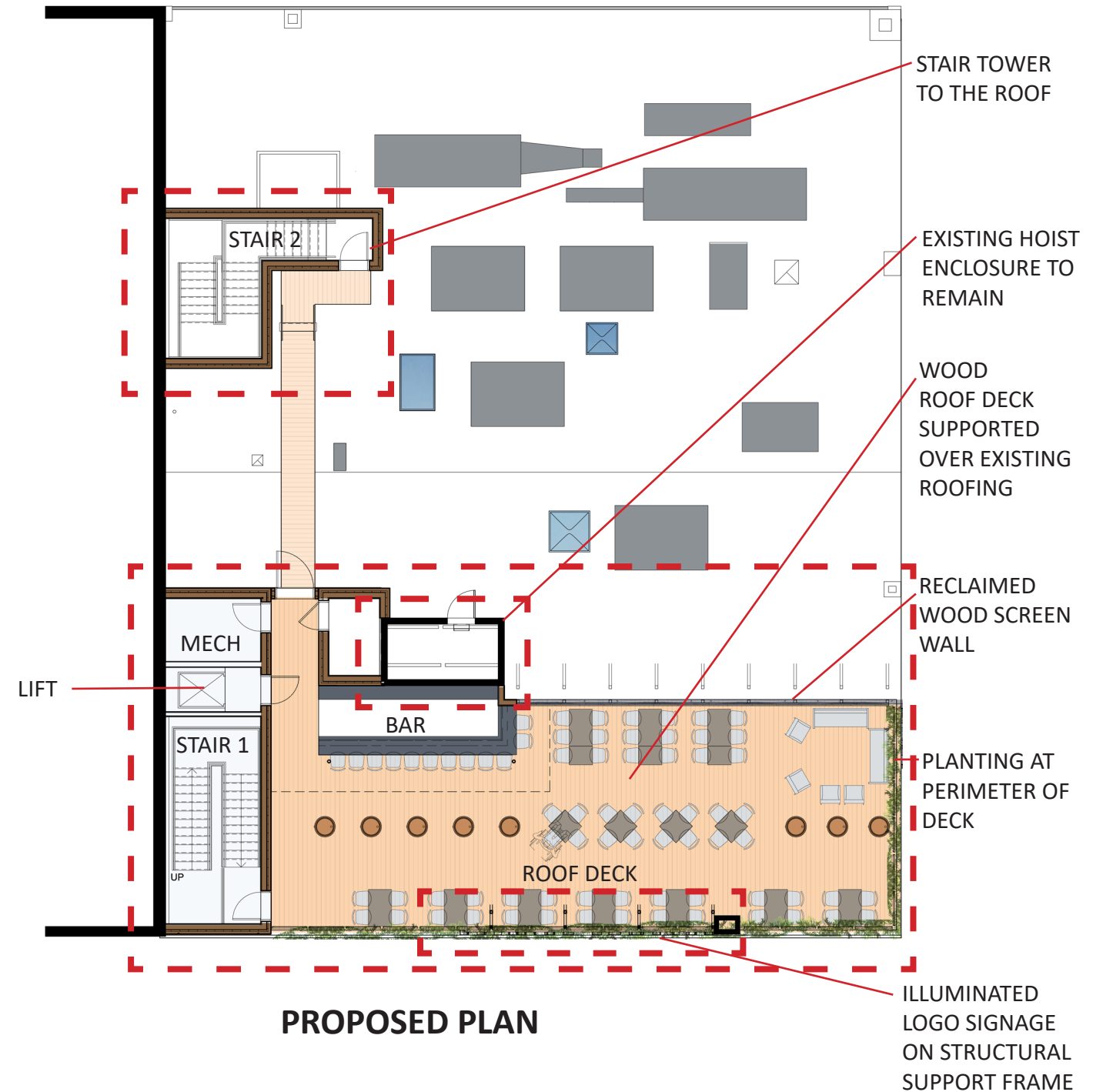

**PROPOSED PLAN**

# EXTERIOR MODIFICATIONS - SITE SECTION

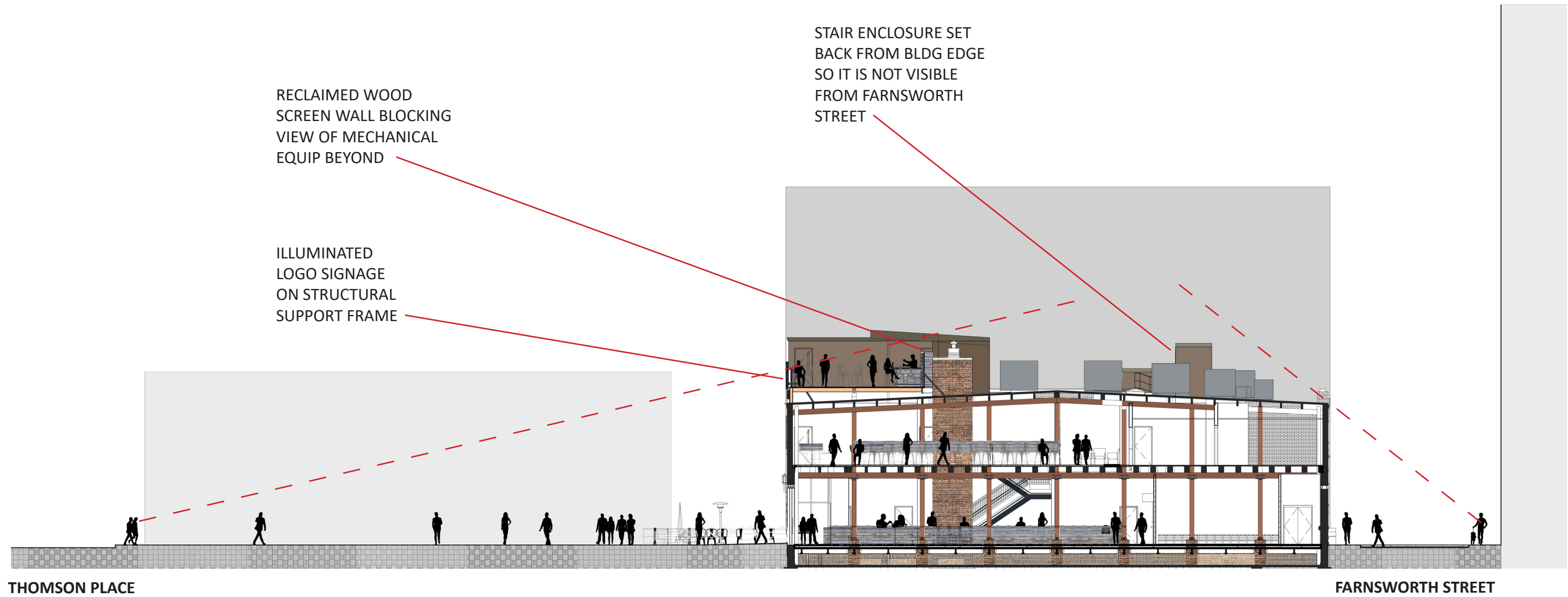

RECLAIMED WOOD  
SCREEN WALL BLOCKING  
VIEW OF MECHANICAL  
EQUIP BEYOND

ILLUMINATED  
LOGO SIGNAGE  
ON STRUCTURAL  
SUPPORT FRAME

STAIR ENCLOSURE SET  
BACK FROM BLDG EDGE  
SO IT IS NOT VISIBLE  
FROM FARNSWORTH  
STREET

THOMSON PLACE

FARNSWORTH STREET

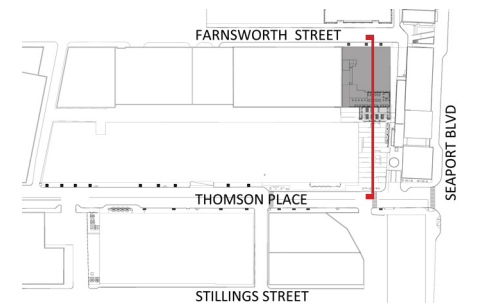

47 FARNSWORTH STREET RENOVATION  
Fort Point - Boston, MA

Whitlock Design Group  
681 Main Street, Suite 3-31  
Waltham, MA 02451  
(781) 647-8008  
www.whitlockdesigns.com



# EXTERIOR MODIFICATIONS - EXISTING AND PROPOSED SOUTH ELEVATION



EXISTING CONDITIONS ELEVATION



PROPOSED ELEVATION



47 FARNSWORTH STREET RENOVATION  
Fort Point - Boston, MA

Whitlock Design Group  
681 Main Street, Suite 3-31  
Waltham, MA 02451  
(781) 647-8008  
www.whitlockdesigns.com



# EXTERIOR MODIFICATIONS - EXISTING AND PROPOSED NORTH ELEVATION



EXISTING CONDITIONS ELEVATION



PROPOSED ELEVATION



47 FARNSWORTH STREET RENOVATION  
Fort Point - Boston, MA

Whitlock Design Group  
681 Main Street, Suite 3-31  
Waltham, MA 02451  
(781) 647-8008  
www.whitlockdesigns.com



# EXTERIOR MODIFICATIONS - EXISTING SOUTH ELEVATION

---



EXISTING CONDITIONS ELEVATION



# EXTERIOR MODIFICATIONS - PROPOSED SOUTH ELEVATION



PROPOSED ELEVATION

# EXTERIOR MODIFICATIONS - PROPOSED EAST ELEVATION



# EXTERIOR MODIFICATIONS - EXISTING NORTH ELEVATION

---



EXISTING CONDITIONS ELEVATION

# EXTERIOR MODIFICATIONS - PROPOSED NORTH ELEVATION

---



CORNER SIGNAGE



PROPOSED ELEVATION

# AERIAL VIEW OF PLAZA - EXISTING

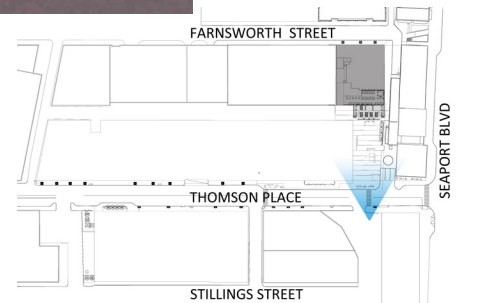

47 FARNSWORTH STREET RENOVATION  
Fort Point - Boston, MA

Whitlock Design Group  
681 Main Street, Suite 3-31  
Waltham, MA 02451  
(781) 647-8008  
www.whitlockdesigns.com



# AERIAL VIEW OF PLAZA - PROPOSED

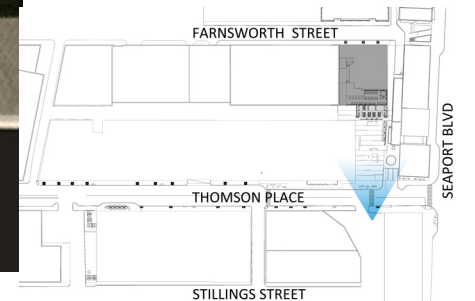

47 FARNSWORTH STREET RENOVATION  
Fort Point - Boston, MA

**Whitlock Design Group**  
681 Main Street, Suite 3-31  
Waltham, MA 02451  
(781) 647-8008  
[www.whitlockdesigns.com](http://www.whitlockdesigns.com)



# EXTERIOR MODIFICATIONS - VIEW FROM FARNSWORTH STREET

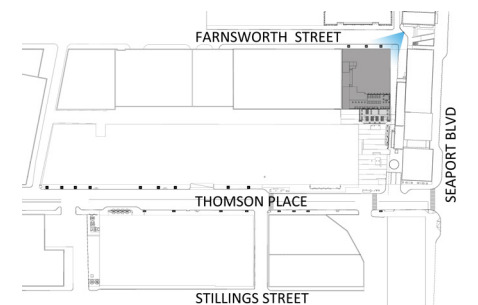

47 FARNSWORTH STREET RENOVATION  
Fort Point - Boston, MA

Whitlock Design Group  
681 Main Street, Suite 3-31  
Waltham, MA 02451  
(781) 647-8008  
www.whitlockdesigns.com



# EXTERIOR MODIFICATIONS - VIEW FROM THOMSON PLACE



Whitlock  
DESIGN GROUP



47 FARNSWORTH STREET RENOVATION  
Fort Point - Boston, MA

Whitlock Design Group  
681 Main Street, Suite 3-31  
Waltham, MA 02451  
(781) 647-8008  
[www.whitlockdesigns.com](http://www.whitlockdesigns.com)





# EXTERIOR MODIFICATIONS - VIEW FROM PLAZA



47 FARNSWORTH STREET RENOVATION  
Fort Point - Boston, MA

Whitlock Design Group  
681 Main Street, Suite 3-31  
Waltham, MA 02451  
(781) 647-8008  
[www.whitlockdesigns.com](http://www.whitlockdesigns.com)



# ROOF MOCKUP PHOTOS



VIEW 1 - DOWN FARNSWORTH STREET



VIEW 2 - FROM PASSAGEWAY



VIEW 3 - FROM THOMSON PLACE



VIEW 4 - FROM STAIRS AT SEAPORT BOULEVARD



47 FARNSWORTH STREET RENOVATION  
Fort Point - Boston, MA

Whitlock Design Group  
681 Main Street, Suite 3-31  
Waltham, MA 02451  
(781) 647-8008  
www.whitlockdesigns.com



# ROOF MOCKUP PHOTOS



VIEW 1 - FROM RAMP AT SEAPORT BOULEVARD



VIEW 2 - FROM MBTA VENT STACK



VIEW 3 - FROM PARKING LOT ACROSS THOMSON PLACE



VIEW 4 - FROM CORNER OF SHAKE SHACK

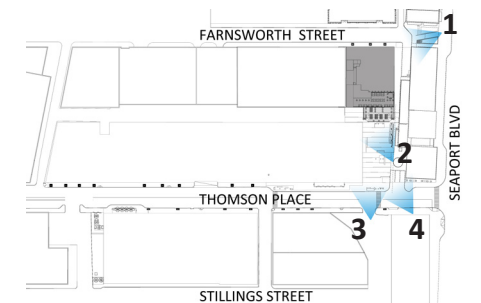

# EXTERIOR MODIFICATIONS - ROOF DECK SECTION

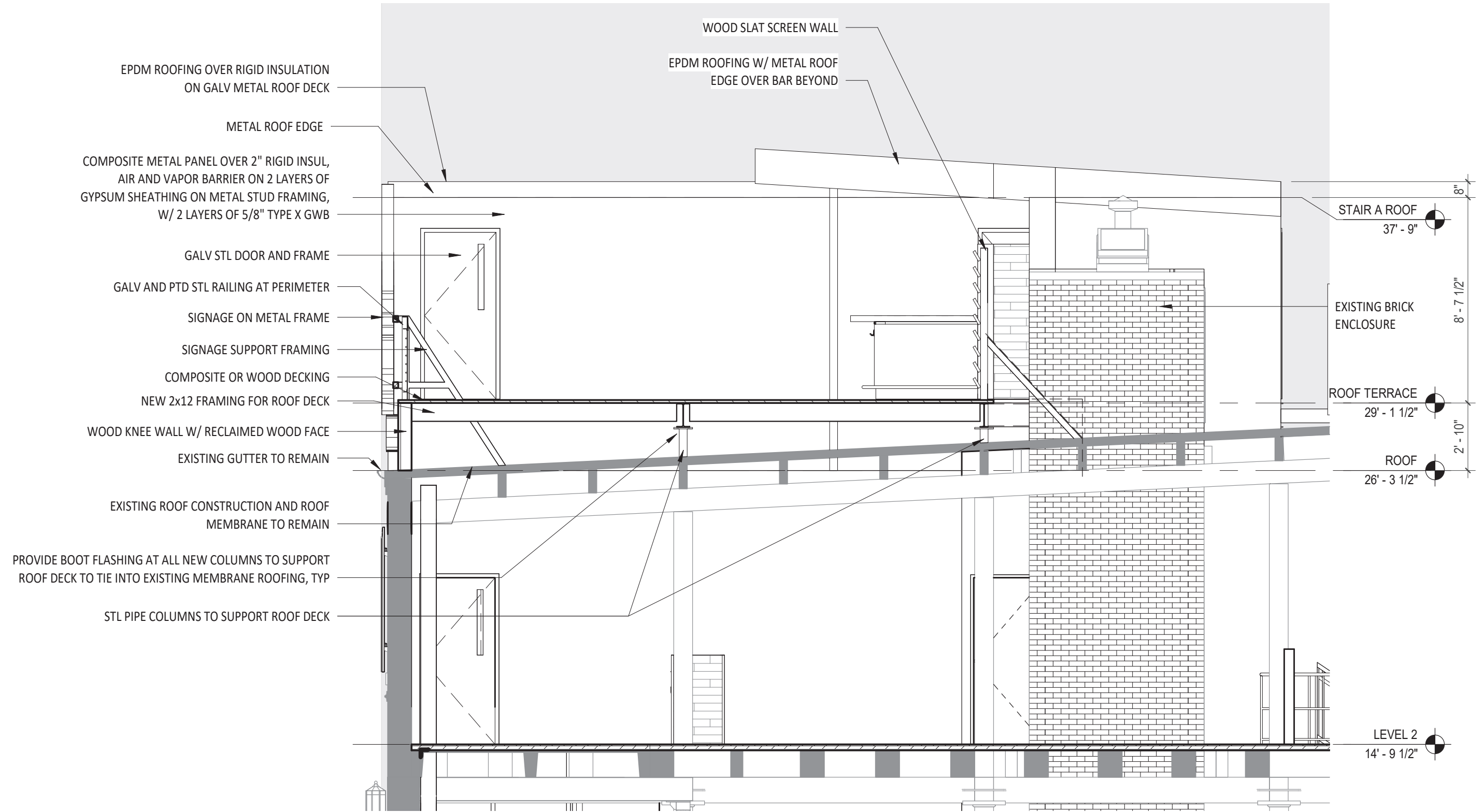

# EXTERIOR MODIFICATIONS - ROOF TERRACE RAILING

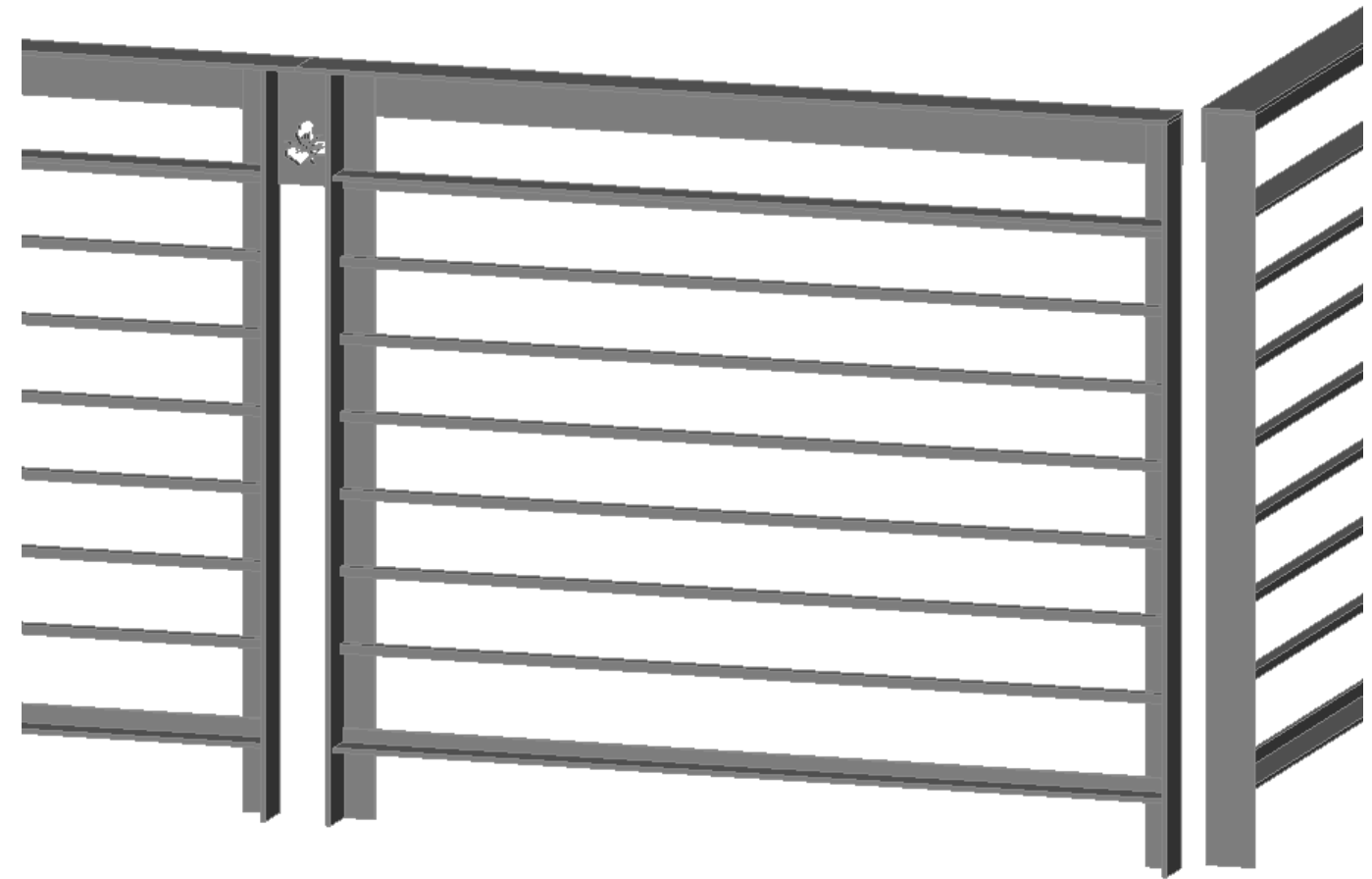
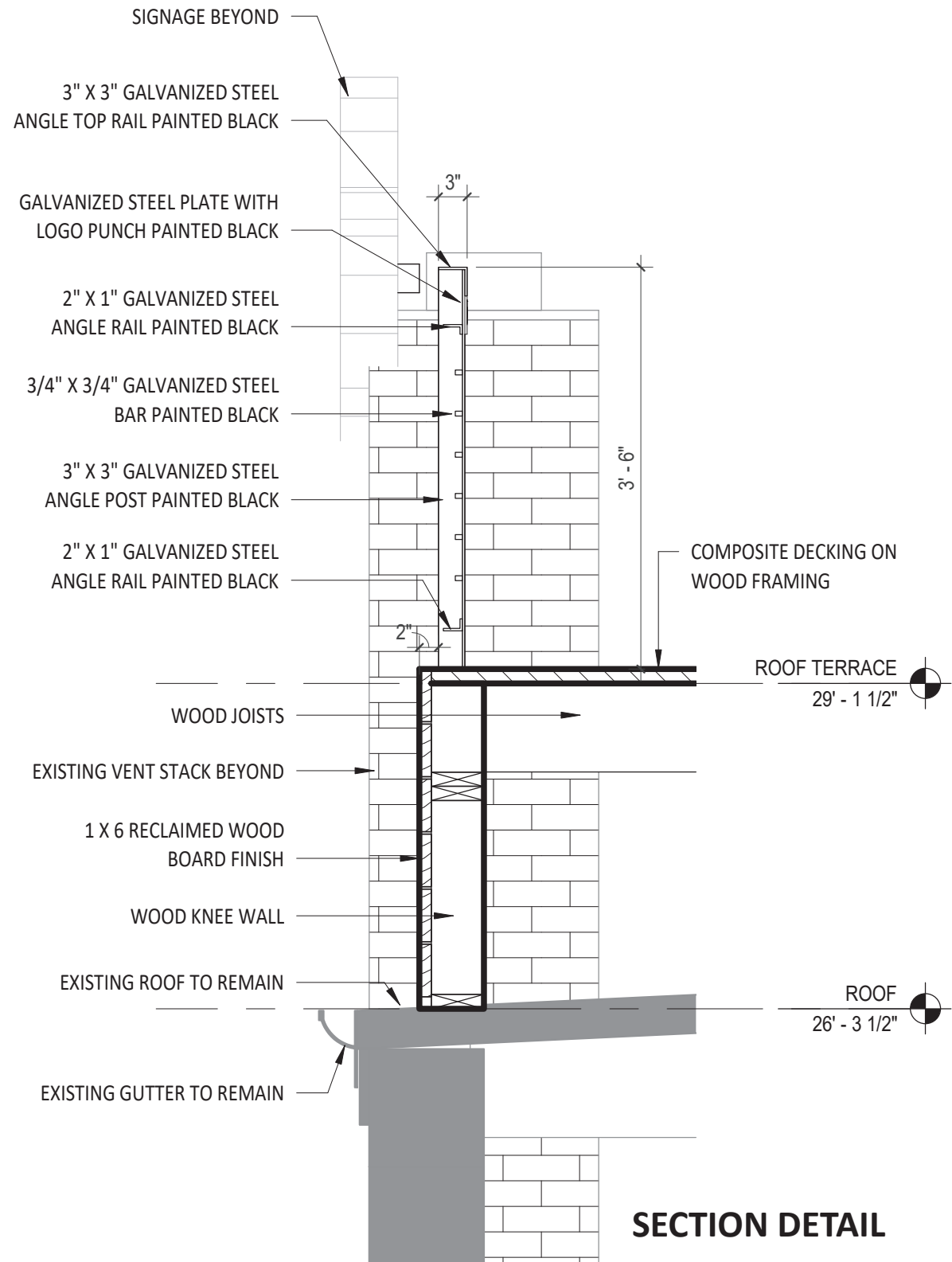

3D MODEL VIEW

# EXTERIOR MODIFICATIONS - ROOF TERRACE WOOD SCREEN

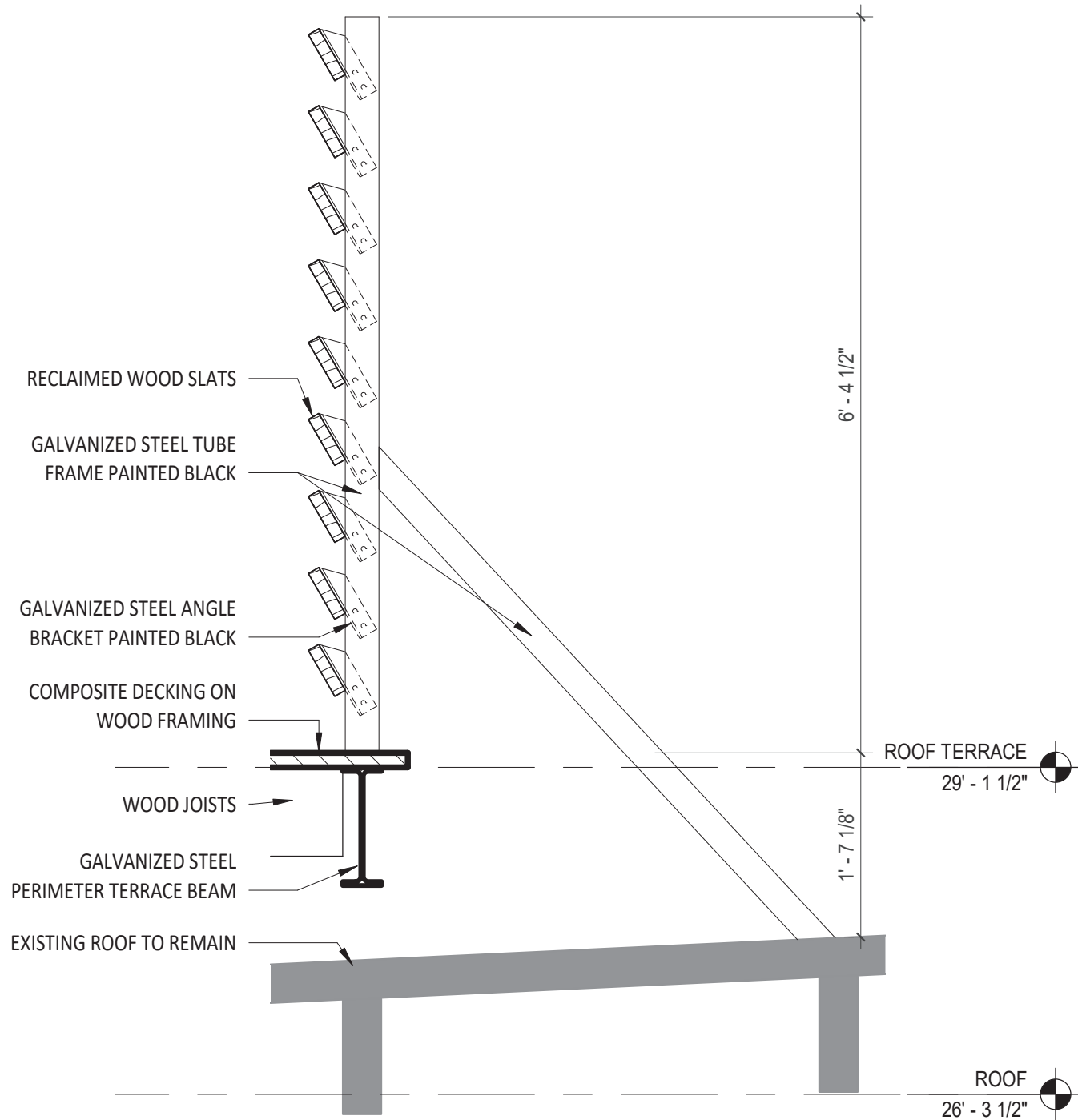

SECTION DETAIL

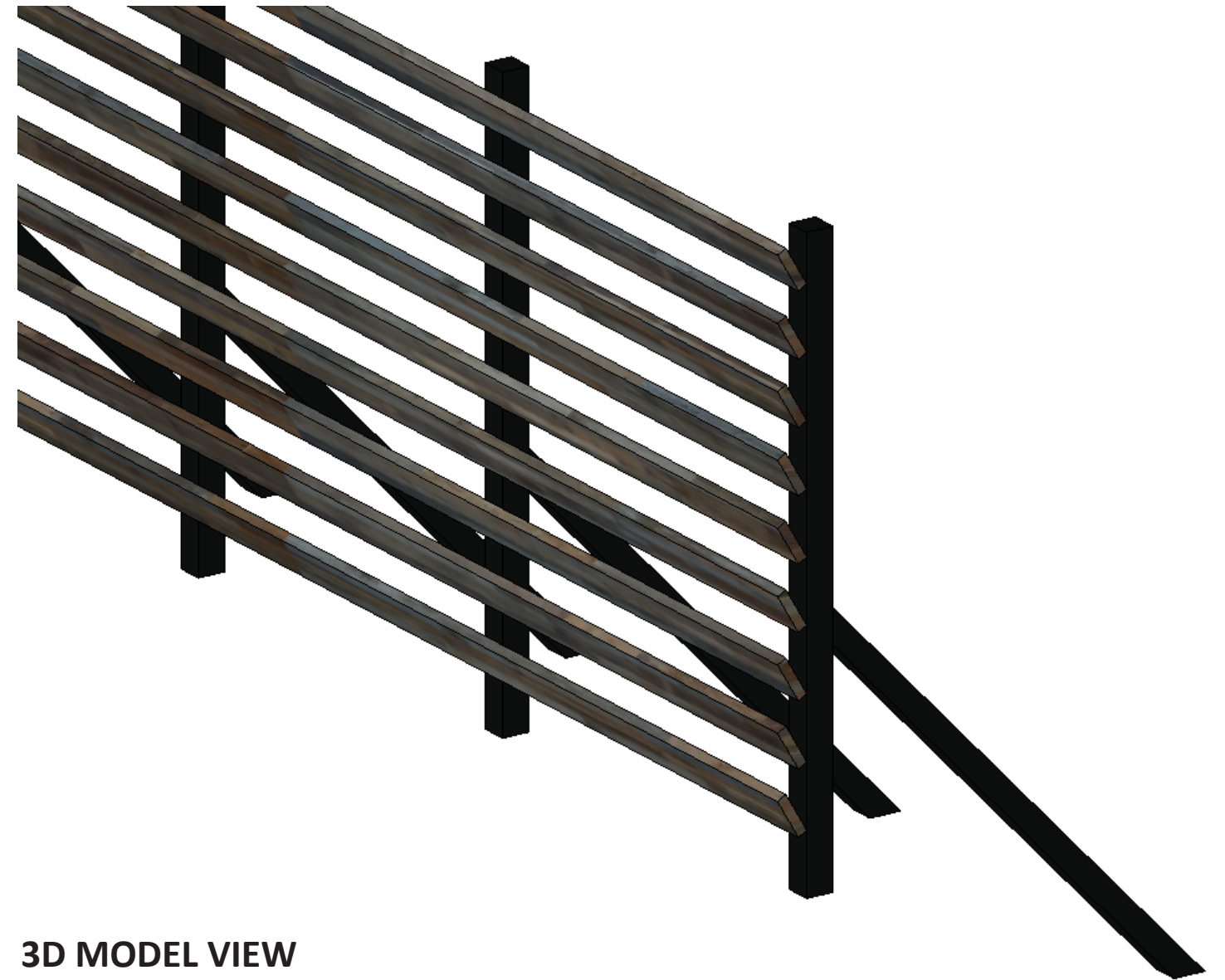

3D MODEL VIEW

# EXTERIOR MODIFICATIONS - ROOF TERRACE SIGNAGE DETAIL

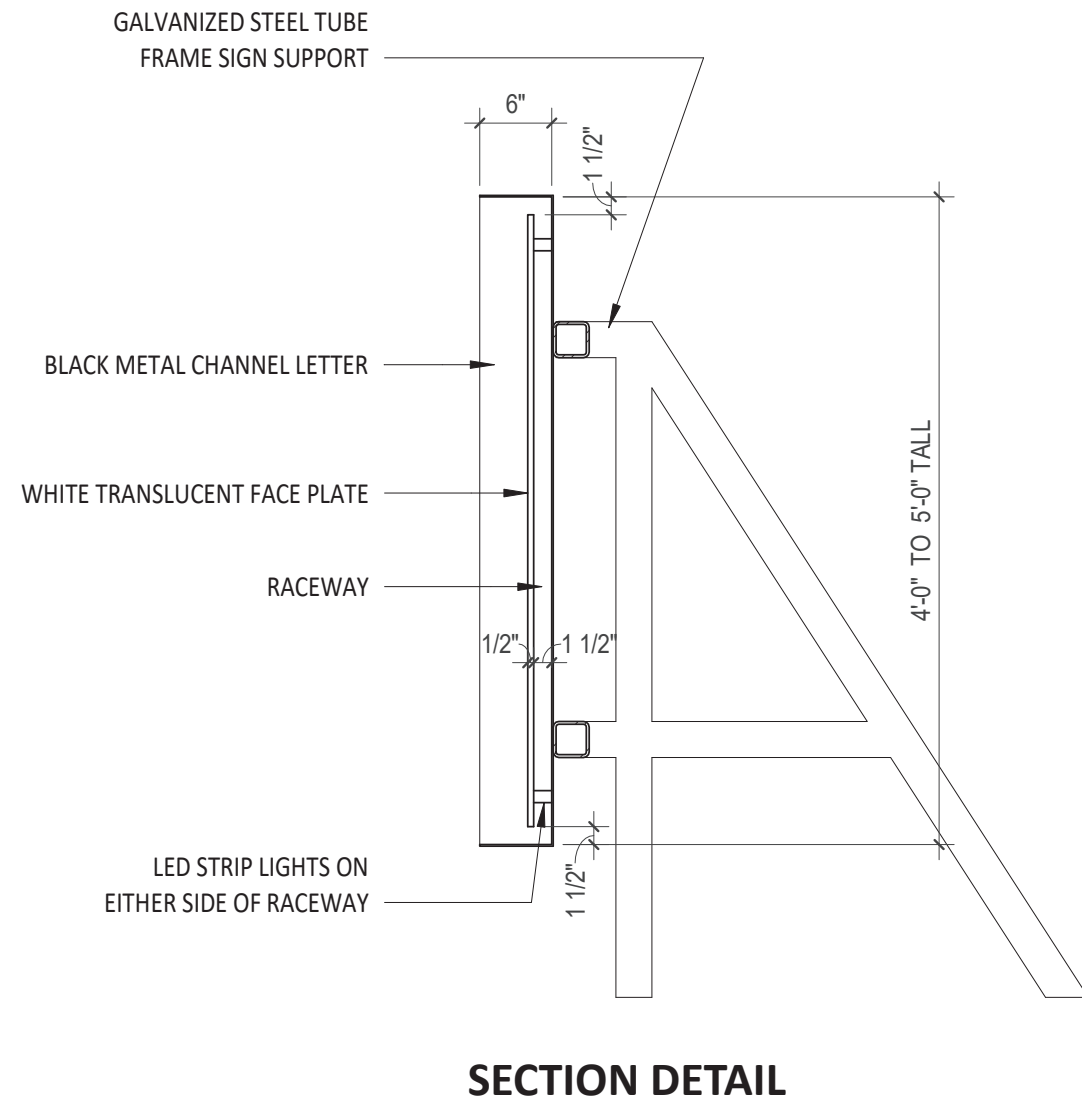

**SECTION DETAIL**

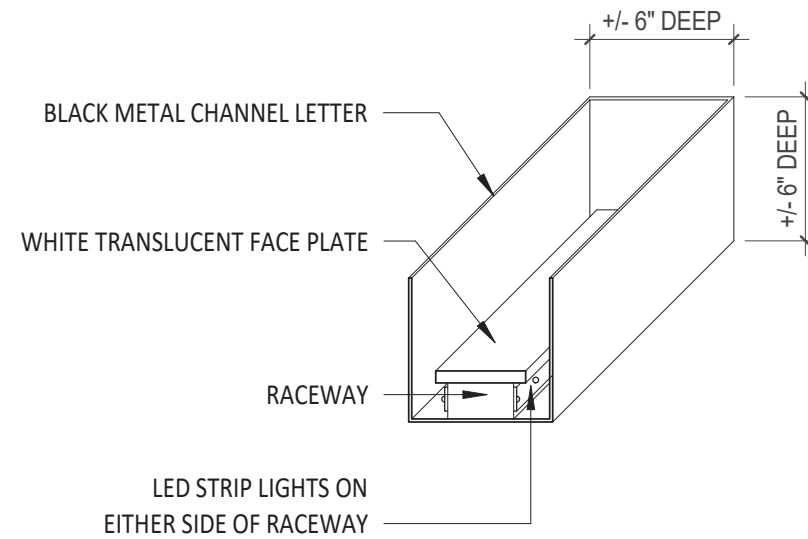

**SECTION AXON VIEW**

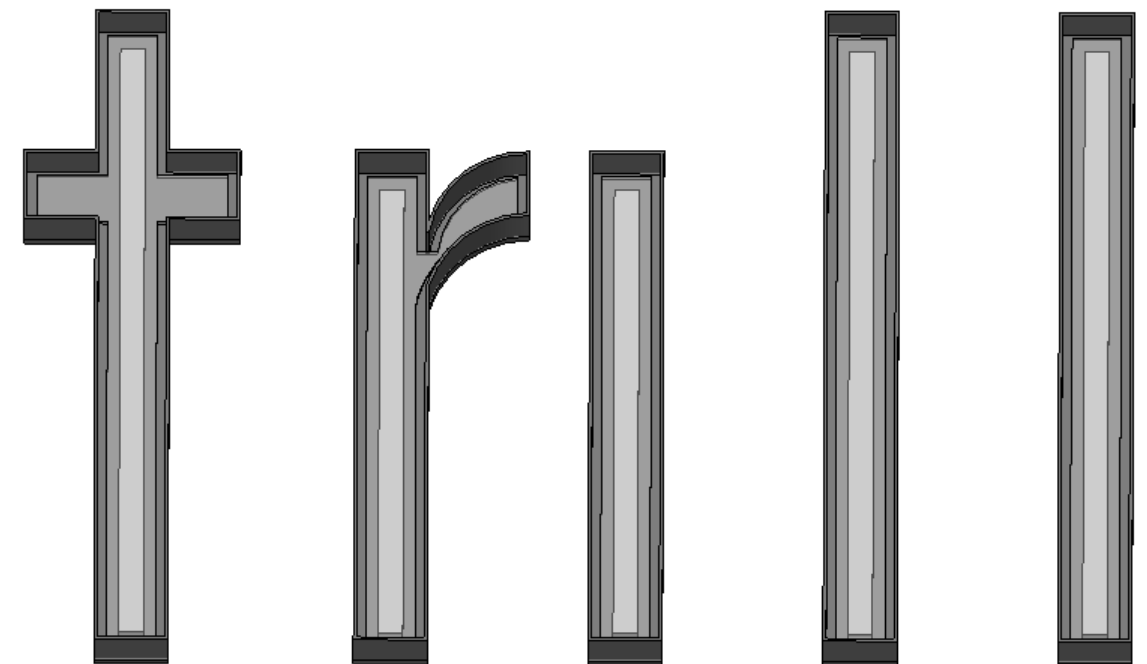

**3D MODEL VIEW**

# EXTERIOR MODIFICATIONS - PATIO DETAILS

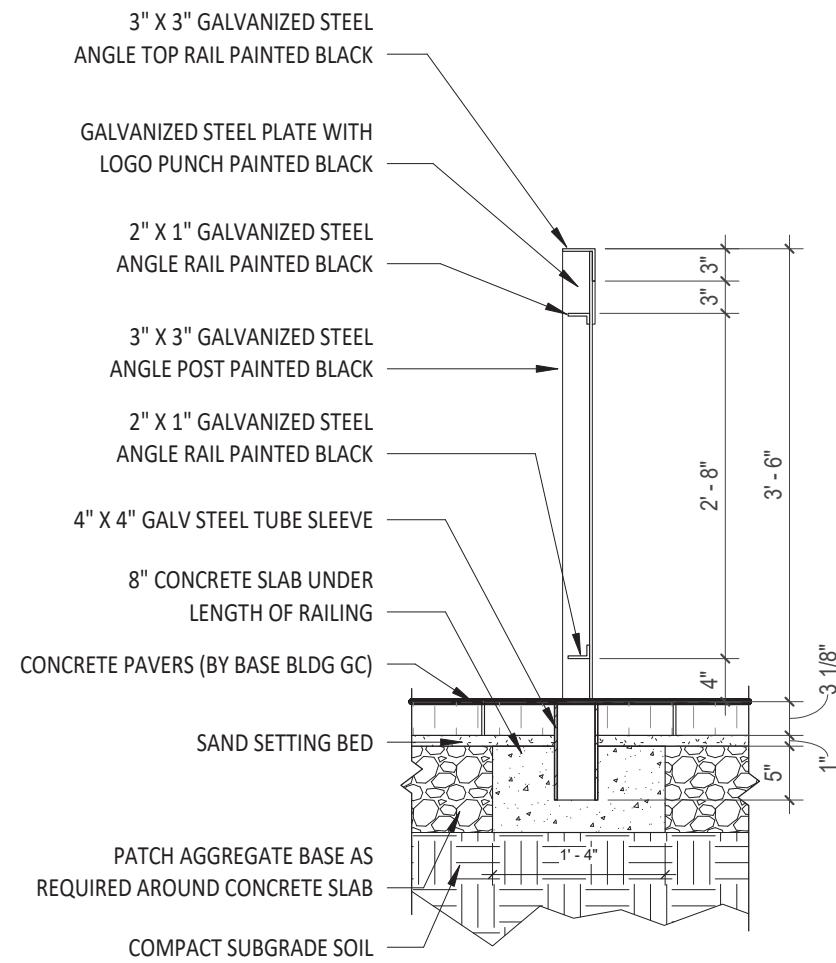

REMOVABLE RAILING SECTION DETAIL

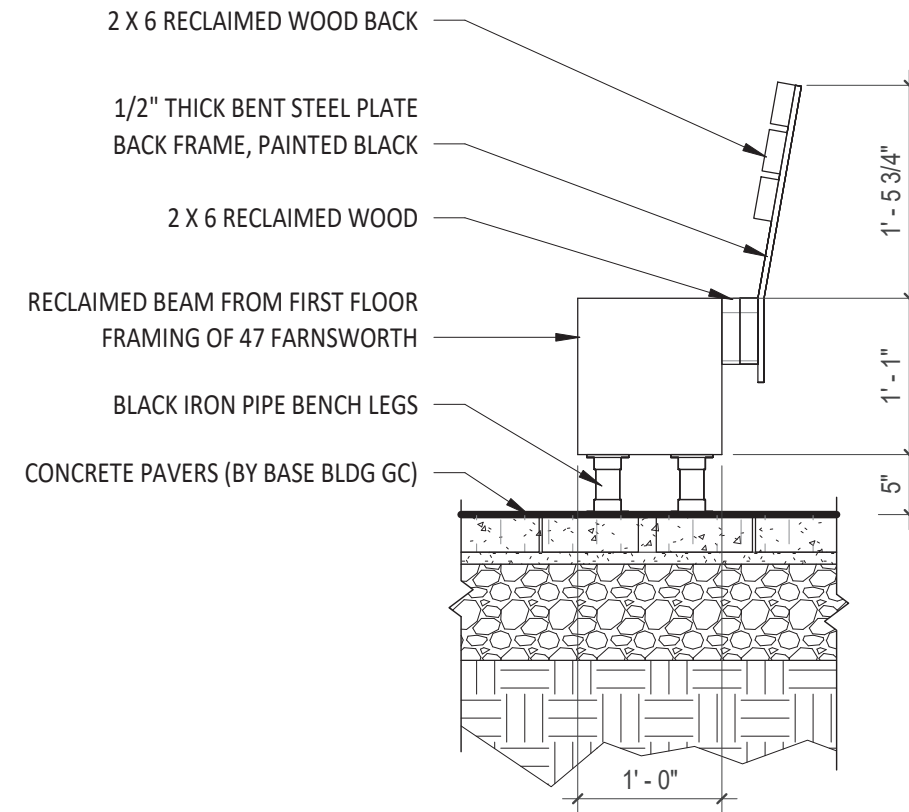

BENCH SECTION DETAIL

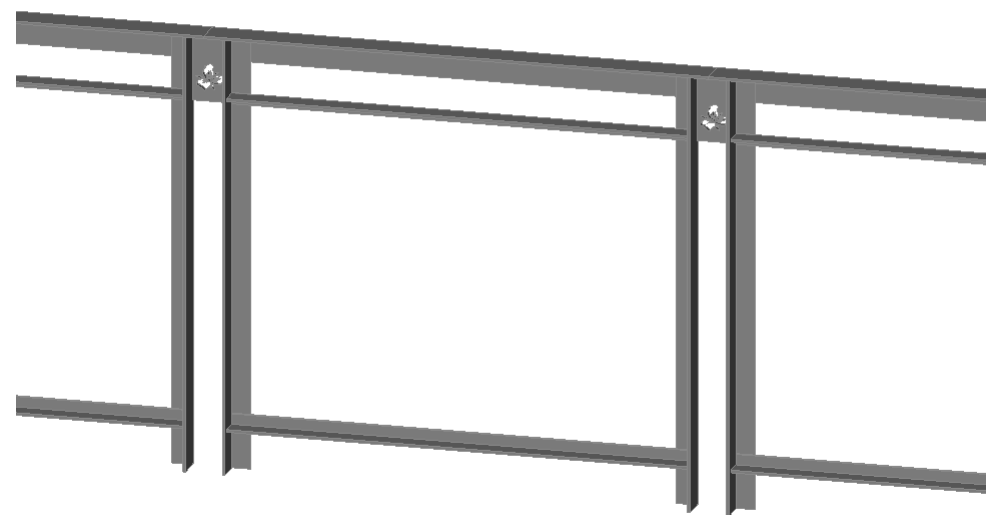

REMOVABLE RAILING 3D MODEL VIEW



BENCH 3D MODEL VIEW



# ROOF DECK

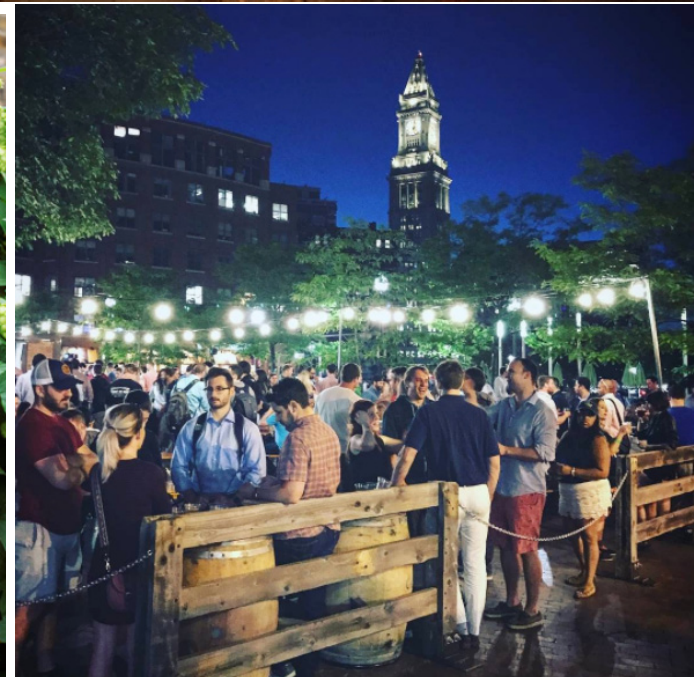

# EXTERIOR FURNITURE

---

