

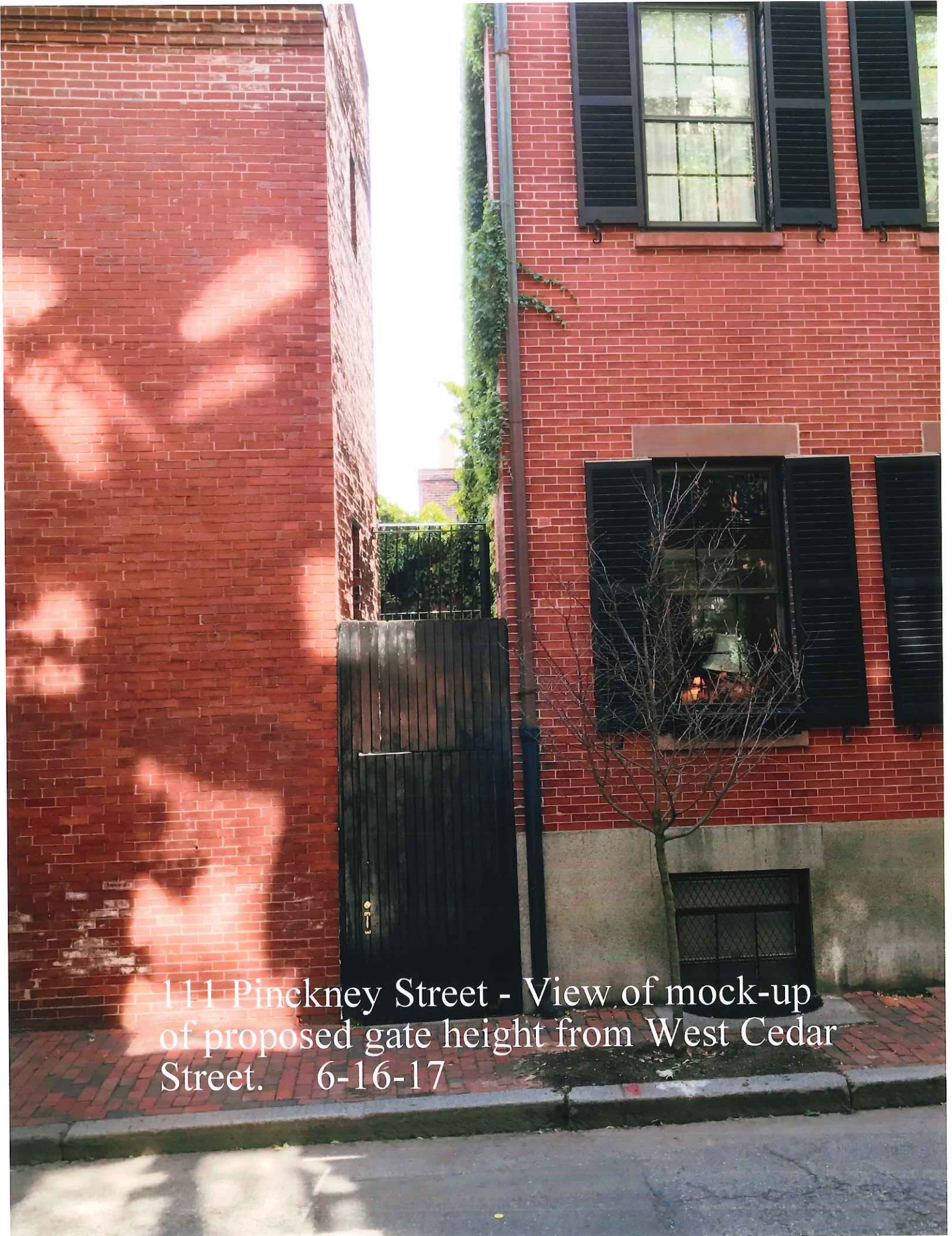

111 Pinckney Street
View from West Cedar of original location
of fire escape access gate.

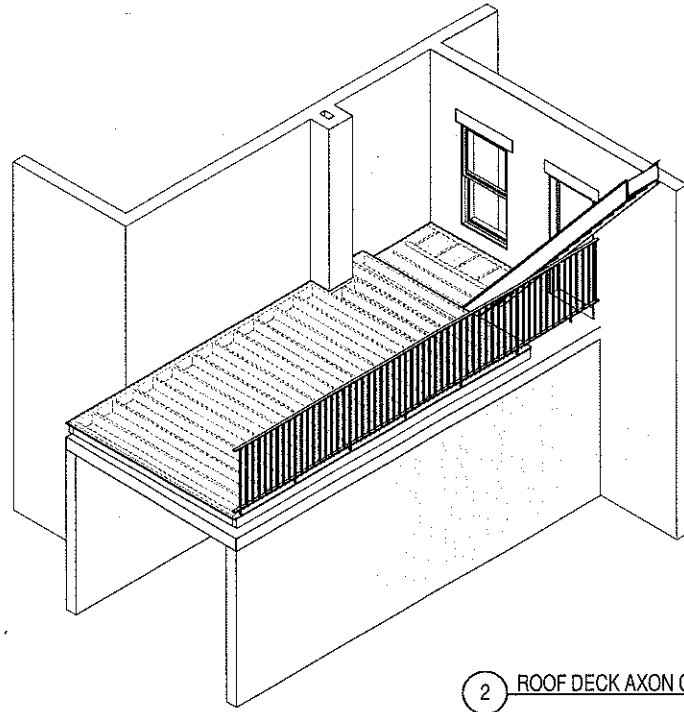

111 Pinckney Street - View of mock-up
of proposed gate height from West Cedar
Street. 6-16-17



2 ROOF DECK AXON Copy 1

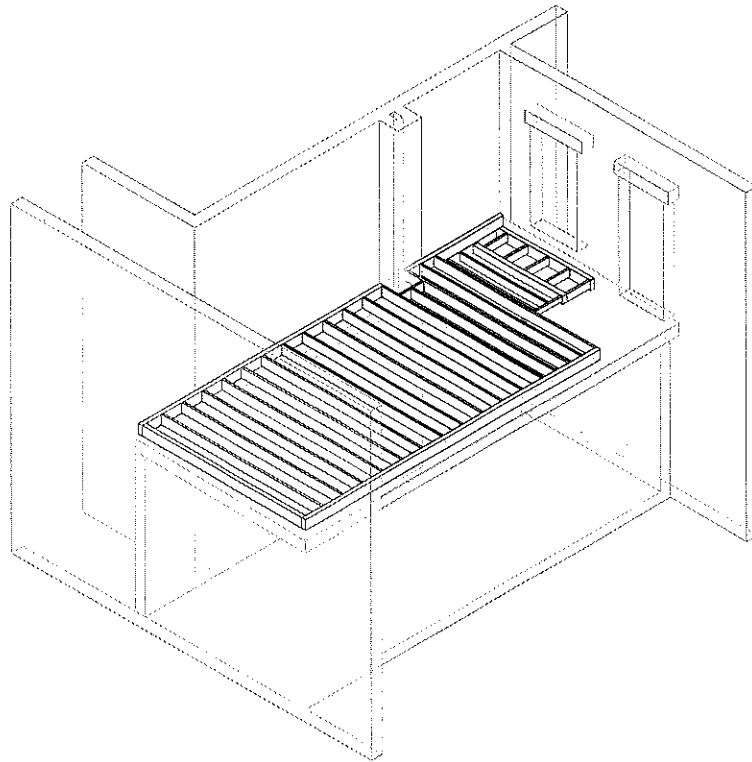

7 ROOF DECK AXON

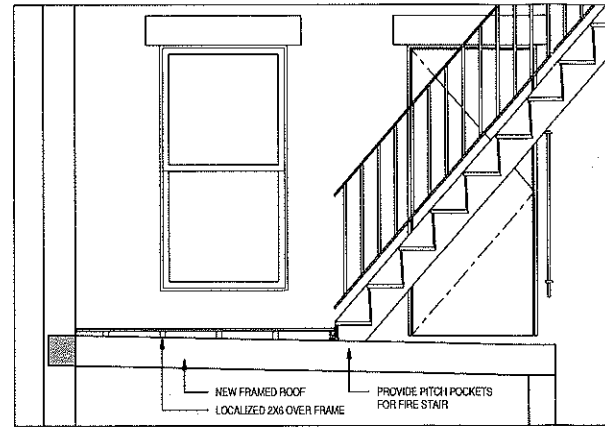

9 Section 1
1/2" = 1'-0"

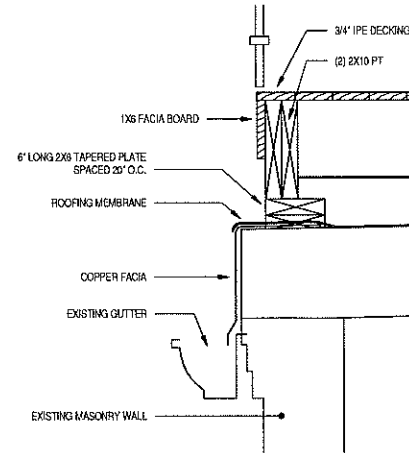

8 PROPOSED SECTION1 - Callout 2
1 1/2" = 1'-0"

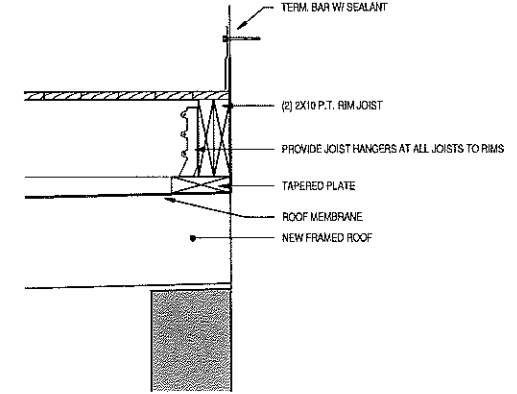

5 PROPOSED SECTION1 - Callout 1
1 1/2" = 1'-0"

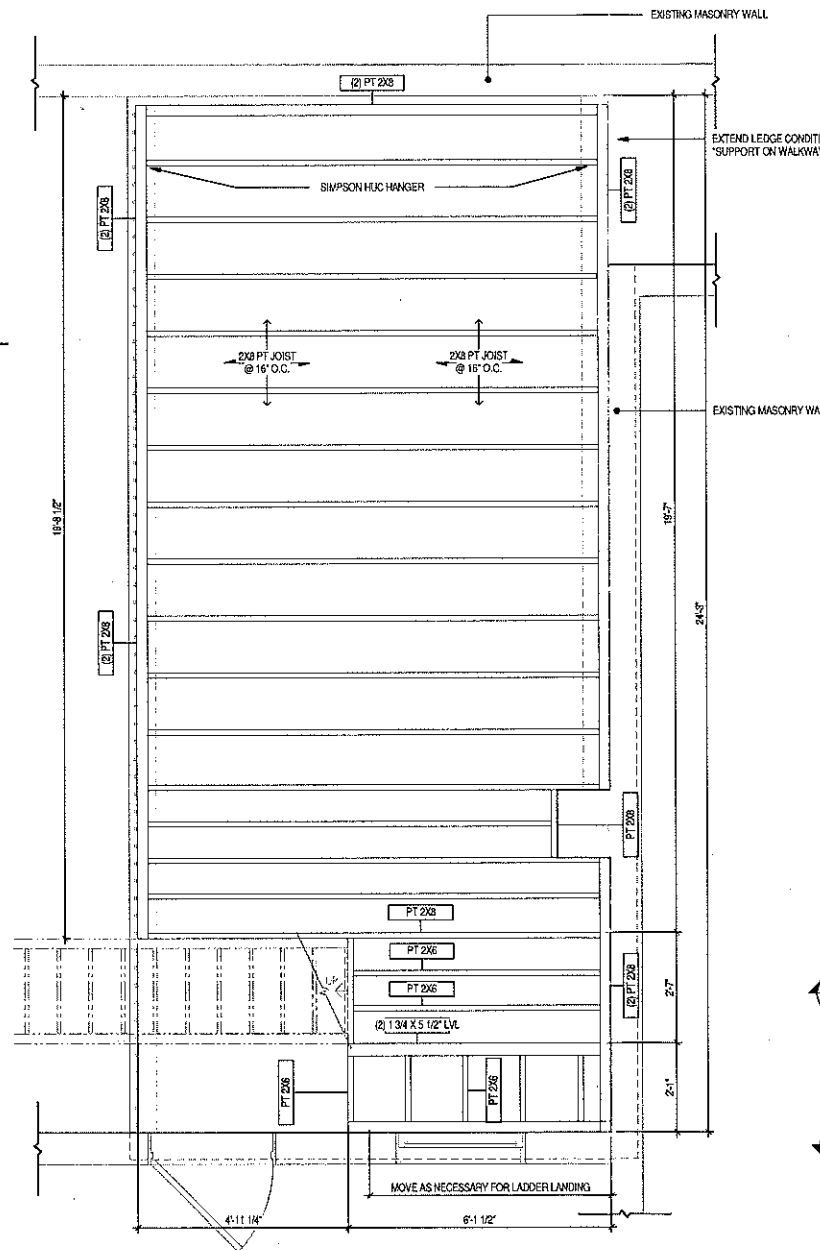

6 PROPOSED DECK FRAMING
1/2" = 1'-0"

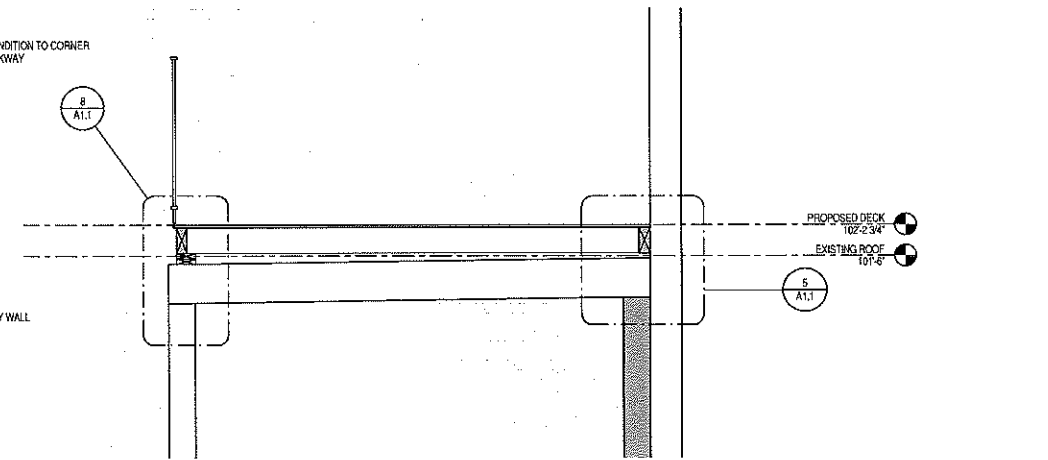

4 PROPOSED SECTION1
1/2" = 1'-0"

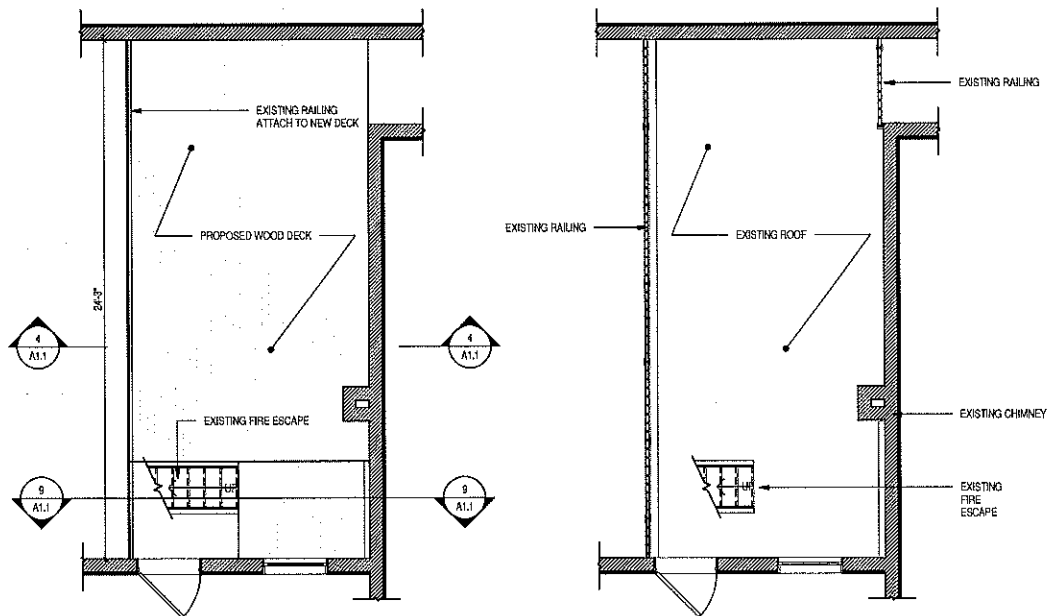

1 PROPOSED ROOF DECK
1/4" = 1'-0"

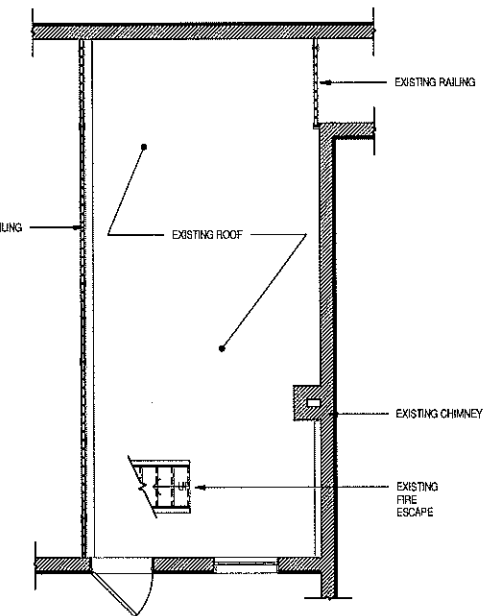

3 EXISTING ROOF
1/4" = 1'-0"

Timothy Burke
ARCHITECTURE

142 BENELEY STREET, BOSTON MASSACHUSETTS 02118
P: 617.266.1332 | W: timothyburke.com | F: 617.266.1118

DATE	REV.	DATE	DESCRIPTION
06/19/17			

PROJECT STATUS

PROPOSED ROOF DECK

111 PICKNEY STREET
BOSTON, MA
DECK ADDITION

A1.1