

# DILLON'S PATIO

955 BOYLSTON STREET  
BOSTON, MA 02115

PREPARED FOR:  
The BACK BAY ARCHITECTURAL COMMISSION

## GLYNN HOSPITALITY GROUP

83 CENTRAL STREET  
BOSTON, MA



PROJECT TEAM:  
OWNER:  
Glynn Hospitality Group, LLC  
83 Central Street  
Boston, MA 02109  
(617) 451-7400  
ARCHITECT:  
Platt Anderson Freeman Architects  
4 Belgrade Avenue  
Boston, MA 02131  
(617) 323-3500  
www.PAFAA.com

**DILLON'S**  
955 Boylston Street  
Boston, MA 02115

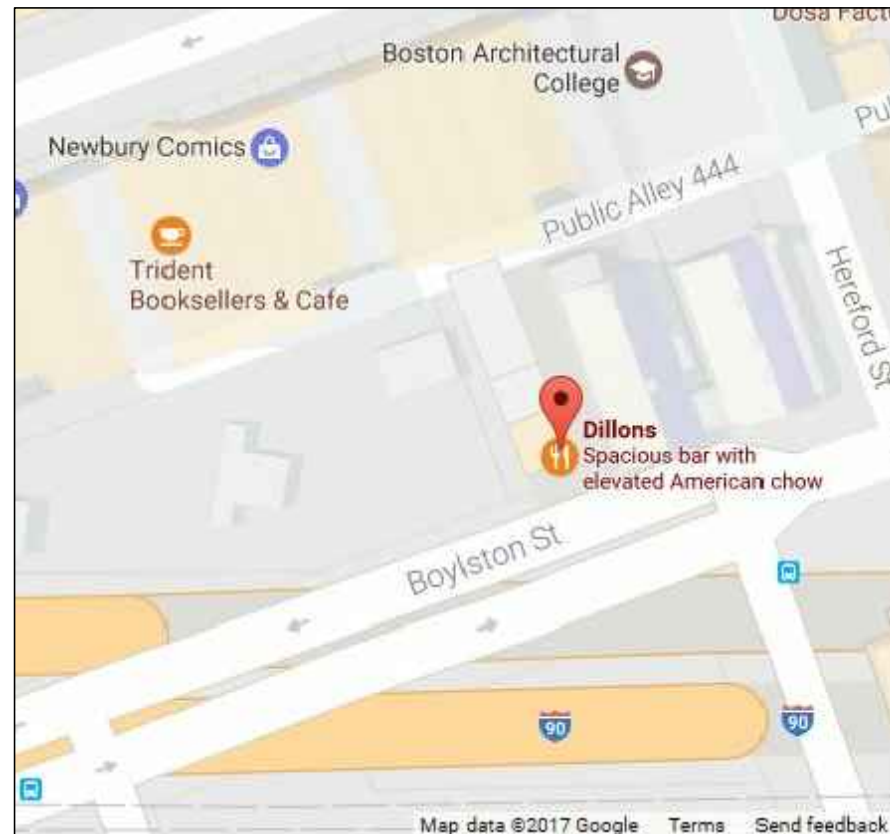

LOCATION PLAN

### PROPOSED SCOPE OF WORK

- A. Construct 6' tall screen wall with a TV cabinet
- B. Mount two flat screen TVs on brackets attached to an existing masonry wall.

DRAWING LIST	
A-0	COVER
A-1	PLAN
A-2	AXONOMETRIC VIEWS
A-3	PATIO VIEWS
A-4	STREET VIEWS
A-5	DETAILS

DRAWN: JF  
CHECKED:  
DATE: 19 May 2017  
SCALE: AS NOTED

SHEET NUMBER  
**A -0**  
Cover

GARAGE  
KER & DONOHUE

AMERICAN LEAGUE  
P. NO. 120-488-7800  
FAX NO. 415-554-9441  
WWW.AMERICANLEAGUE.COM  
SEASIDE BALL PARK, SEASIDE, CA

Please See Host Inside  
for all Patio & Dining  
Room Seating





AMERICAN LEAGUE  
P. 123 456 7890  
M. 101 202 300 400  
W. 500 600 700 800  
H. 900 001  
AT BAT BALL

Please See Back Entrance  
for all Parks & Botting  
Booths







Please See Host Inside  
For All Patio & Dining  
Room Seating

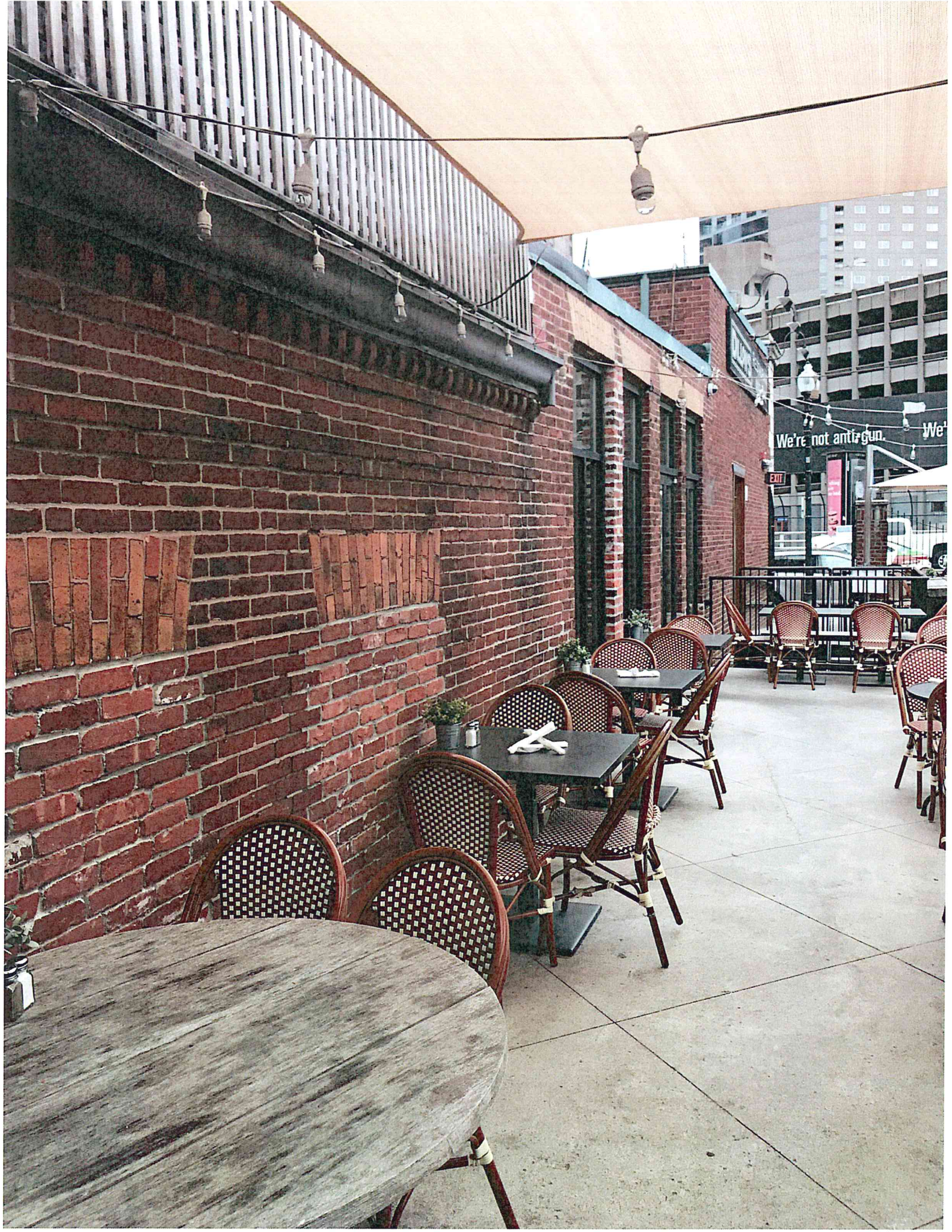

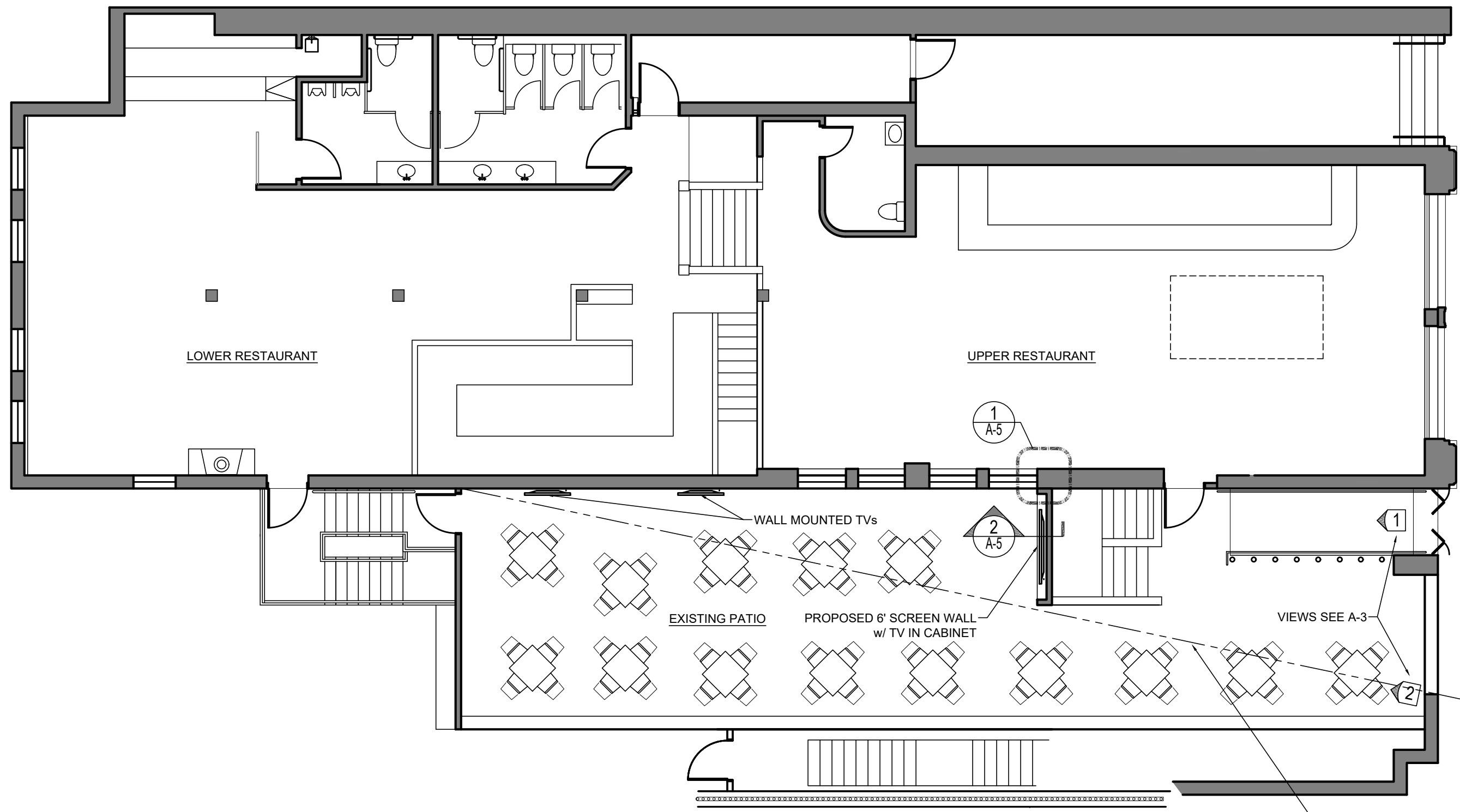

DRAWING NAME: DILLONS TV PLAN.DWG  
LAYOUT: A -1

DRAWN:	JF
CHECKED:	
DATE:	19 May 2017
SCALE:	AS NOTED

SHEET NUMBER  
**A - 1**  
Plan





Proposed overhead view from northwest

TVs MOUNTED TO WALL ON BRACKETS. BRACKET ATTACHMENTS TO BE THROUGH MORTAR JOINTS ONLY.

PROPOSED 6' TALL SCREEN WALL WITH FLAT SCREEN TV IN CABINET. CABINET TO HAVE LOCKABLE PANEL DOORS



Proposed overhead view from southwest

TVs MOUNTED TO WALL ON BRACKETS. BRACKET ATTACHMENTS TO BE THROUGH MORTAR JOINTS ONLY.

NEW 6' TALL SCREEN WALL IN LOCATION OF EXISTING BACK RAILING

ALL OTHER ELEMENTS ARE EXISTING TO REMAIN



1. Existing view along sight line (See plan)



2. Existing view up entrance ramp



3. Proposed view along sight line (See plan)



4. Proposed view up entrance ramp

PROPOSED SCREEN WALL BEYOND



Proposed view from street

NOTE: THE TOP VIEW IS SHOWN FROM STANDING HEIGHT ON THE STREET. THE GOOGLE STREET VIEW IS FROM AN ELEVATED PERSPECTIVE.

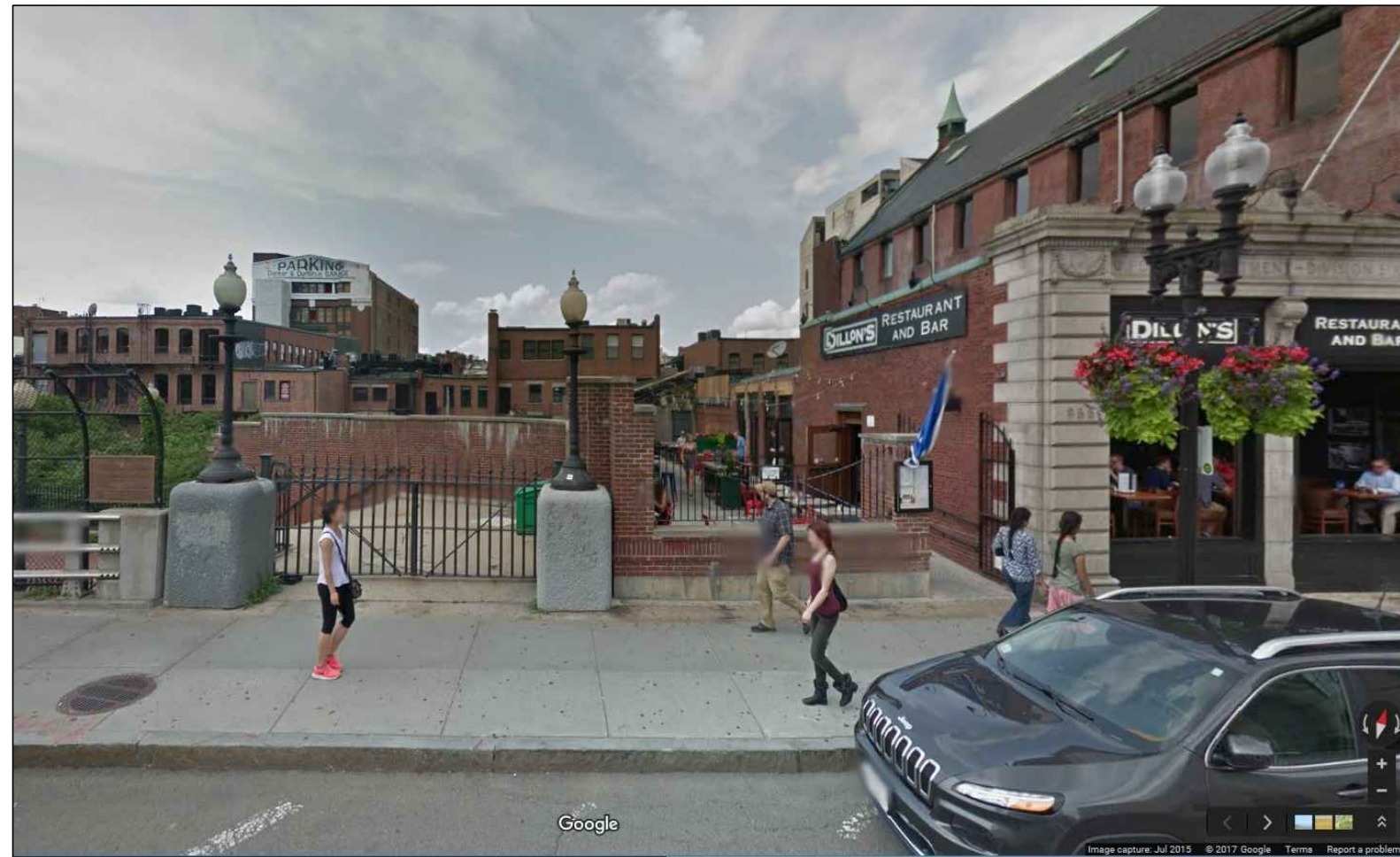

Existing Google street view

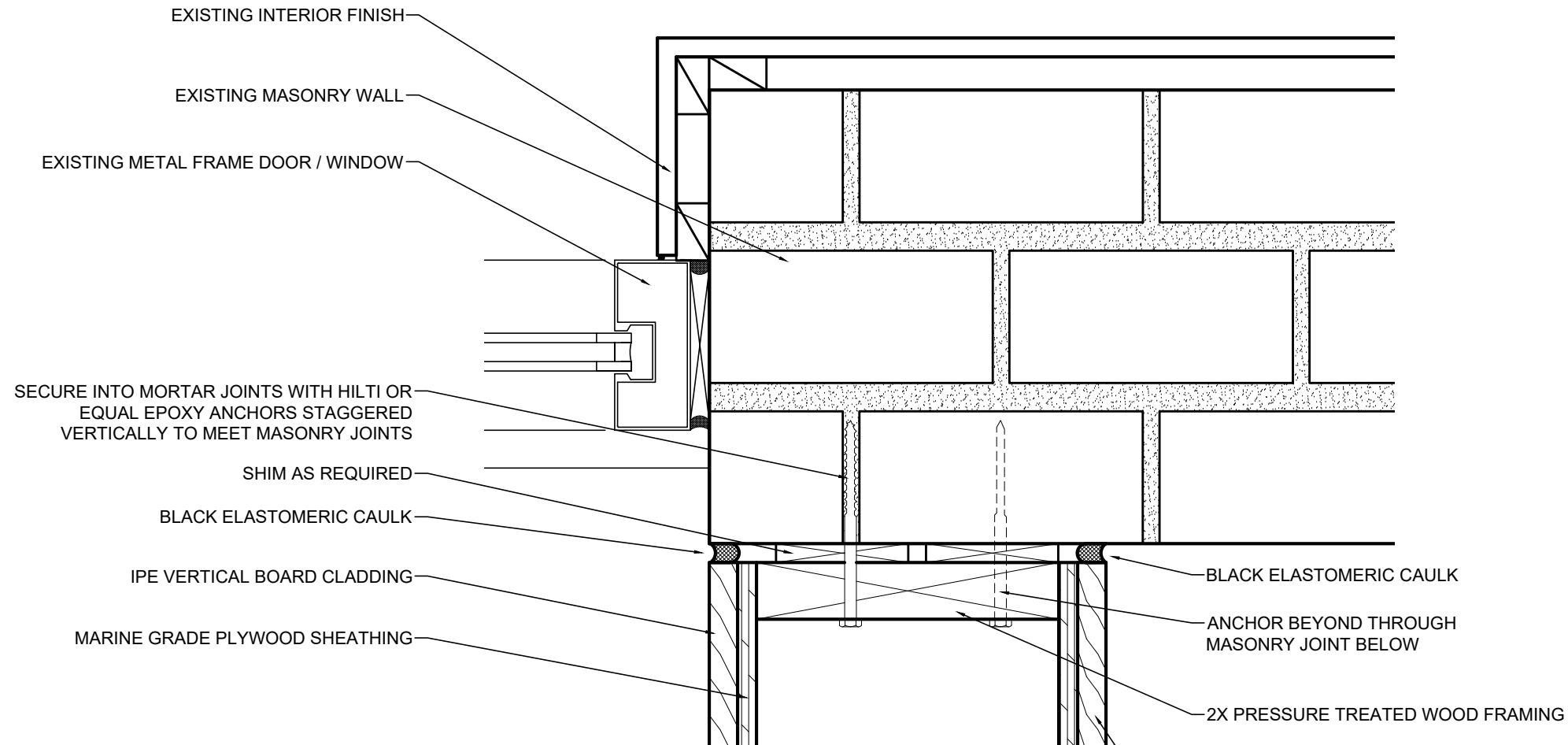

**1** PLAN DETAIL @ EXISTING WALL  
3"=1'-0"

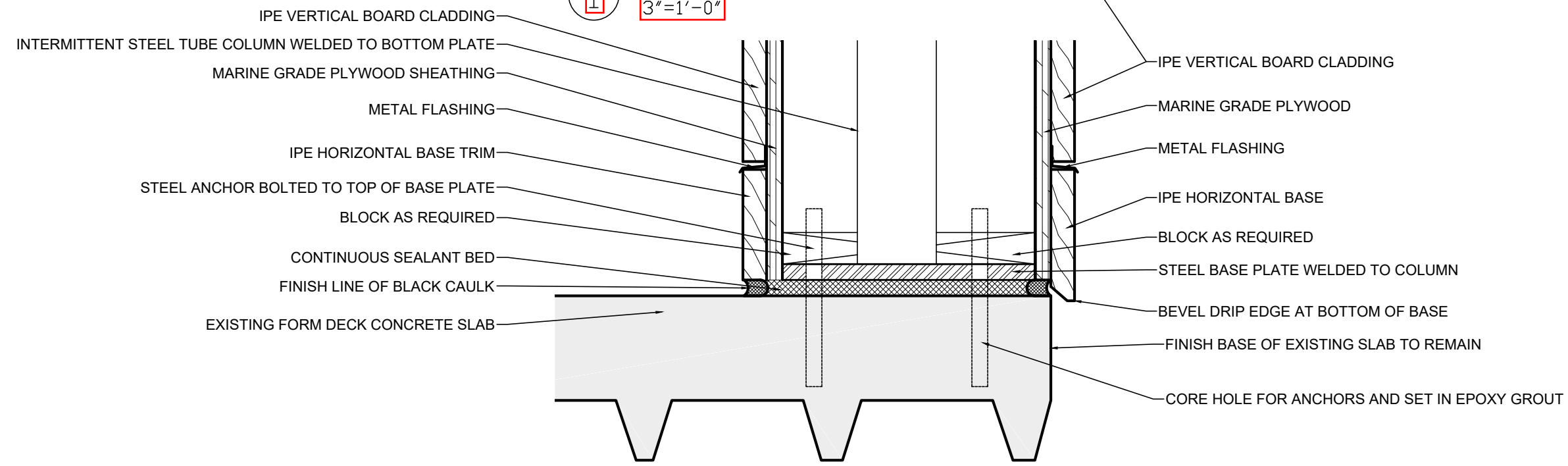

**2** SECTION DETAIL @ BASE  
3"=1'-0"

DRAWING NAME: DILLONS TV PLAN.DWG  
LAYOUT: A -5

DRAWN: JF  
CHECKED:  
DATE: 19 May 2017  
SCALE: AS NOTED

SHEET NUMBER  
**A -5**  
Details