

ELEVATION A

CHESTNUT HILL MANOR CONDOMINIUMS, BRIGHTON MASSACHUSETTS

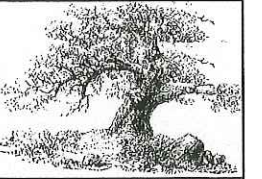

ANNE WELLINGTON
Landscape Design & Construction

14 Olin Avenue
Chester, Massachusetts, 01011
617.872.1373
anne@annewellington.com
www.annewellington.com

CHESTNUT HILL MANOR
BRIGHTON, MA

CHESTNUT HILL MANOR
CONDOMINIUM ASSOCIATION
185 & 189 CHESTNUT HILL AVE
BRIGHTON, MA, 02135

LANDSCAPE
DESIGN
PLAN

PLANTING &
LIGHTING PLAN

ILLUSTRATIVE PLAN
AND
ELEVATION

COVER
PAGE

DATE: MARCH 20, 2017
REV. DATE:

PAGE 1 OF 6

1
6

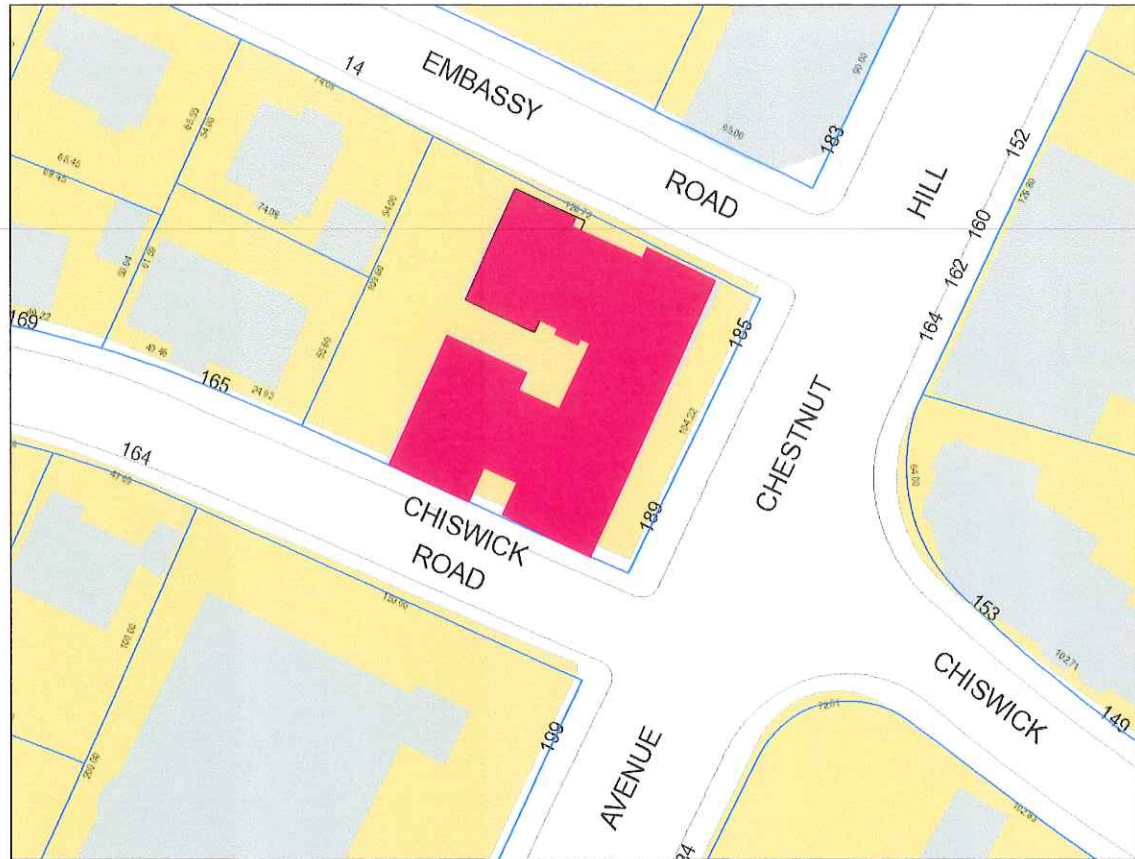

CHESTNUT HILL MANOR BRIGHTON, MASSACHUSETTS

BUILT 1927
ARCHITECT/ BUILDER:
BARNEY B. LEVY

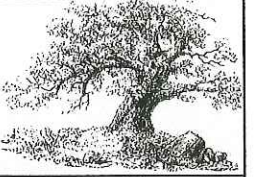

ANNE WELLINGTON
Landscape Design & Construction

14 Olin Avenue
Chester, Massachusetts 01011
617.872.1373
anne@annewellington.com
www.annewellington.com

CHESTNUT HILL
MANOR
BRIGHTON, MA

CHESTNUT HILL MANOR
CONDOMINIUM ASSOCIATION
185 & 189 CHESTNUT HILL AVE
BRIGHTON, MA, 02135

LANDSCAPE
DESIGN
PLAN

PLANTING &
LIGHTING PLAN

LOCI
&
INDEX

LIST OF SHEETS

1. COVER SHEET
2. LOCI AND INDEX
3. EXISTING CONDITIONS PLAN
4. PLANTING PLAN
5. PLANTING DETAILS
6. LIGHTING DETAILS

Plan based on field survey and Boston Geographic Information Systems and is for schematic purposes only. This plan is not based on an actual survey.

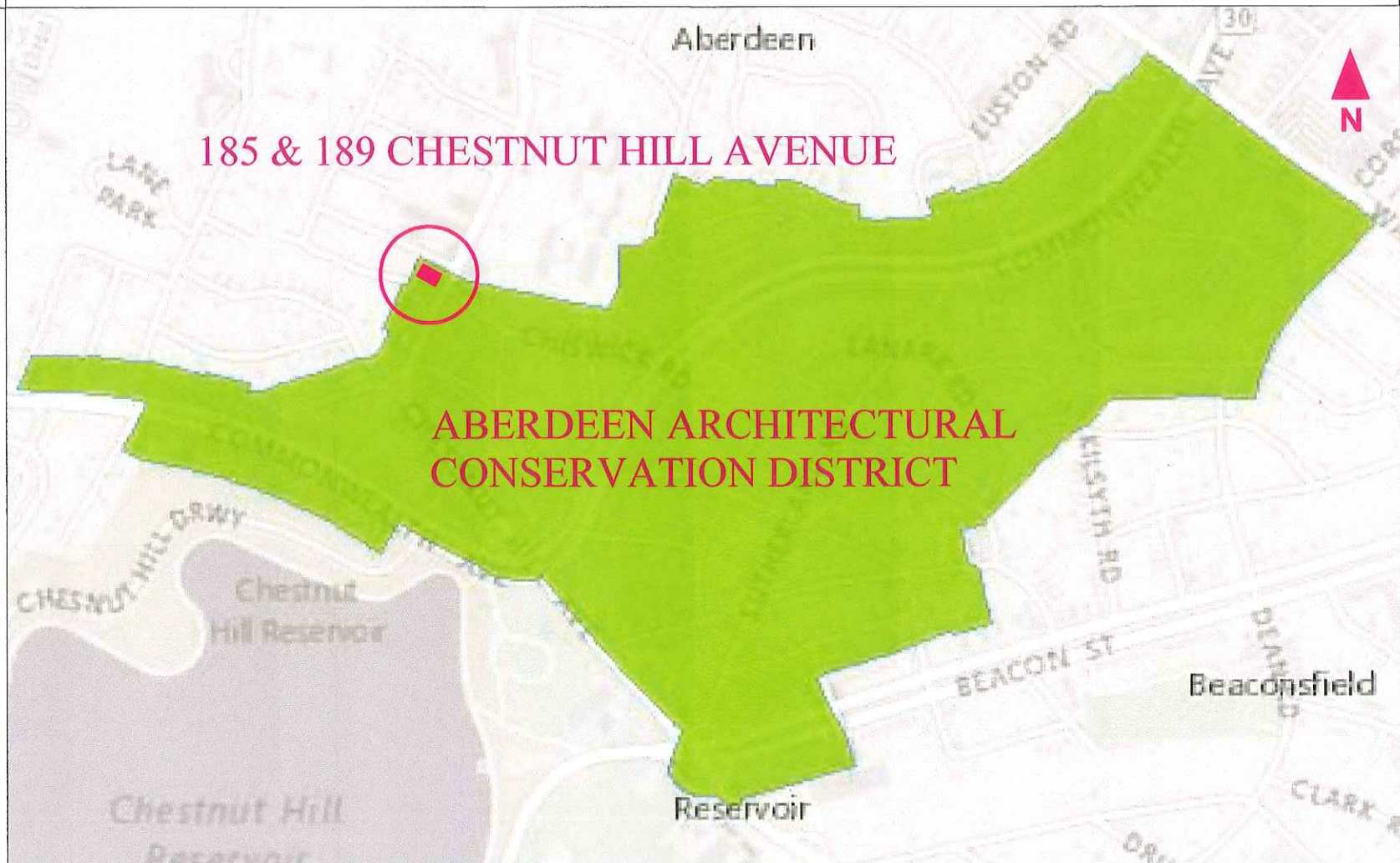

DATE:
MARCH 15, 2017
REV. DATE:

PAGE 2 OF 6
2
6



ANNE WELLINGTON
Landscape Design & Construction

14 Olin Avenue
Chester, Massachusetts 01011
617.872.1373
anne@annewellington.com
www.annewellington.com

CHESTNUT HILL
MANOR
BRIGHTON, MA

CHESTNUT HILL MANOR
CONDOMINIUM ASSOCIATION
185 & 189 CHESTNUT HILL AVE
BRIGHTON, MA, 02135

LANDSCAPE
DESIGN
PLAN

PLANTING &
LIGHTING PLAN

EXISTING
CONDITIONS
PLAN

EXISTING
CONDITIONS
PLAN

DATE:
MARCH 15, 2017
REV. DATE:

PAGE 3 OF 6

3
6

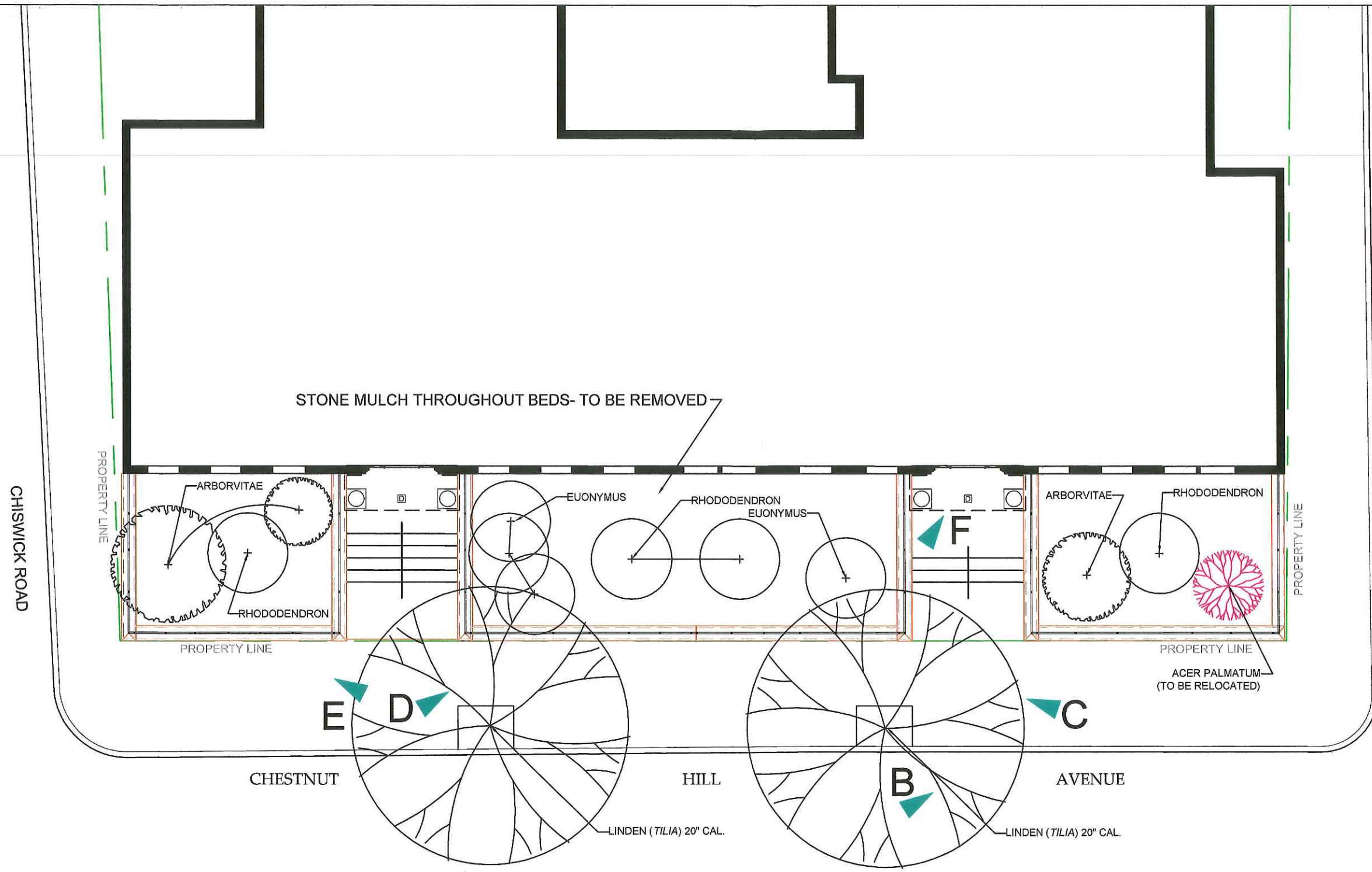

STONE MULCH THROUGHOUT BEDS- TO BE REMOVED

ARBORVITAE
RHODODENDRON

EUONYMUS

RHODODENDRON
EUONYMUS

ARBORVITAE
RHODODENDRON

ACER PALMATUM
(TO BE RELOCATED)

CHESTNUT

HILL

AVENUE

LINDEN (TILIA) 20" CAL.

LINDEN (TILIA) 20" CAL.

NOTES:
JAPANESE MAPLE WILL BE RELOCATED
ALL OTHER PLANTS WILL BE BE REMOVED FOR THE RESTORATION OF EXISTING STUCCO WALLS
ARBORVITAE ARE OVERGROWN AND SEVERELY MISSHAPEN
RHODODENDRONS ARE OVERGROWN
ALL PLANT MATERIAL ARE TOO LARGE FOR THE LOCATION
EUONYMUS ALATA (BURNING BUSH) ARE ON THE INVASIVE SPECIES LIST
ANY NEW PLANTINGS WOULD BE DISPROPORTIONATE TO THE EXISTING PLANTINGS

D DRAIN LOCATION AT BOTTOM OF STAIRWELLS

A-F KEY TO PHOTO LOCATIONS





ANNE WELLINGTON
Landscape Design & Construction

14 Olin Avenue
Chester, Massachusetts 01011
617.872.1975
anne@annewellington.com
www.annewellington.com

CHESTNUT HILL
MANOR
BRIGHTON, MA

CHESTNUT HILL MANOR
CONDOMINIUM ASSOCIATION
185 & 189 CHESTNUT HILL AVE
BRIGTON, MA, 02135

LANDSCAPE
DESIGN
PLAN

PLANTING &
LIGHTING PLAN

PLANTING
LAYOUT
PLAN

PLANTING
PLAN

DATE:
MARCH 20, 2017
REV. DATE:

PAGE 4 OF 6

4
6

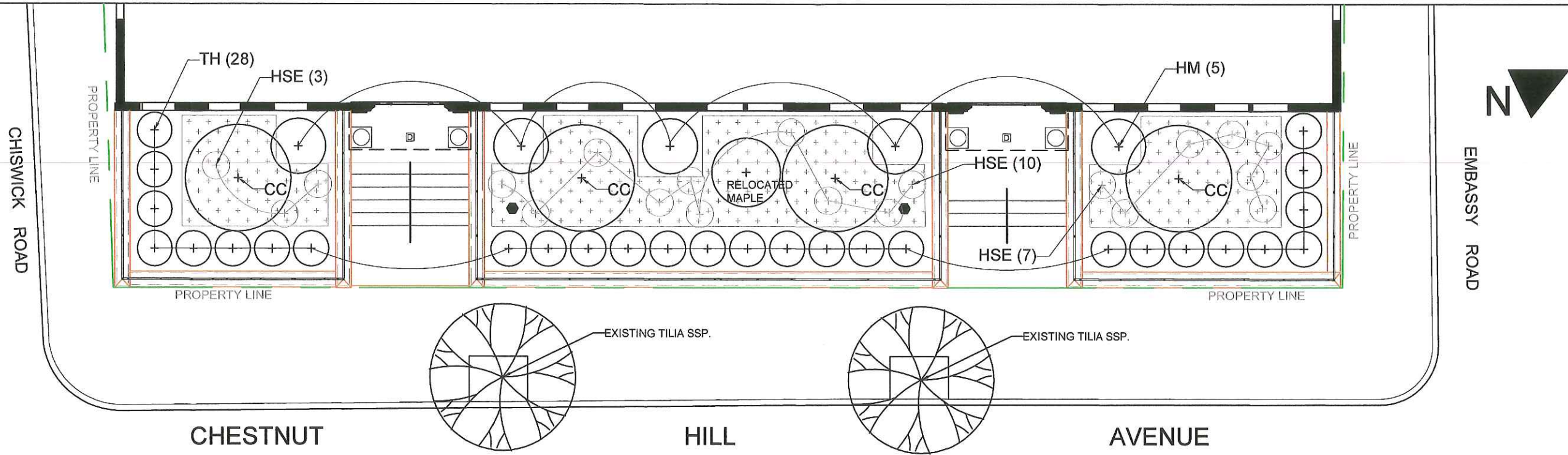

Key	Botanical Name	Common Name	Size	Quantity
CC	Cornus x Rutdans 'Celestial'	Celestial Dogwood	1.75-2" Cal.	4
TH	Taxus 'Hicksii'	Hicks Yew	18-24"	28
HM	Hydrangea macrophylla 'Nikko Blue'	Nikko Blue Hydrangea	5 Gal.	5
HSE	Hosta sieboldiana 'Elegans'	Siebold Hosta	3 Gal.	20
VM	Vinca minor	Vinca, Periwinkle	1 Gal.	50



'CELESTIAL' DOGWOOD



HICKS YEW



NIKKO BLUE HYDRANGEA



SIEBOLD HOSTA



VINCA

NOTE: ALL PLANTS TO BE FIELD LOCATED, SPECIFIC VARIETIES ARE SUBJECT TO CHANGE BASED ON AVAILABILITY.

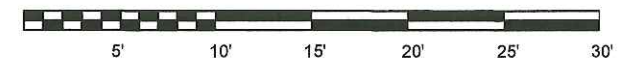

CELESTIAL DOGWOOD (*CORNUS X CELESTIAL*)

Habit: Deciduous, upright growing
 Height: 20'
 Width: 20'
 Color: White
 Season of Bloom: Late Spring, Summer
 Hardiness: Zone 5
 Other Features: Long lasting flowers, disease



NIKKO BLUE HYDRANGRA (*HYDRANGEA 'NIKKO BLUE'*)

Habit: Deciduous
 Height: 10-20'
 Width: 10-20'
 Color: Blue to Pink depending on soil pH
 Season of Bloom: Summer into Fall
 Hardiness: Zone 3-8
 Other Features: Flower heads persist into winter season



HICKSYEW (*TAXUS 'HICKSII'*)

Habit: Evergreen
 Height: 3-4'
 Width: 3-4'
 Color: N/A
 Season of Bloom: N/A
 Hardiness: Zone 4-9
 Other Features: Easily clipped



SIEBOLD HOSTA (*HOSTA SIBOLDIANA 'ELEGANS'*)

Habit: Herbaceous perennial
 Height: 24-36"
 Width: 24-36"
 Color: Large blue leaves, flowers - lavender white bells along stems
 Season of Bloom: Summer
 Hardiness: Zone 4-8
 Other Features: Foliage interest throughout the growing season



VINCA, PERIWINKLE, MYRTLE (*VINCA 'MINOR'*)

Habit: Evergreen Ground Cover
 Height: 6-12"
 Width: 24"
 Color: Dark green foliage, bluish-lavender flowers
 Season of Bloom: Early Spring
 Hardiness: Zone 4-8
 Other Features: Spreading ground cover, hardy

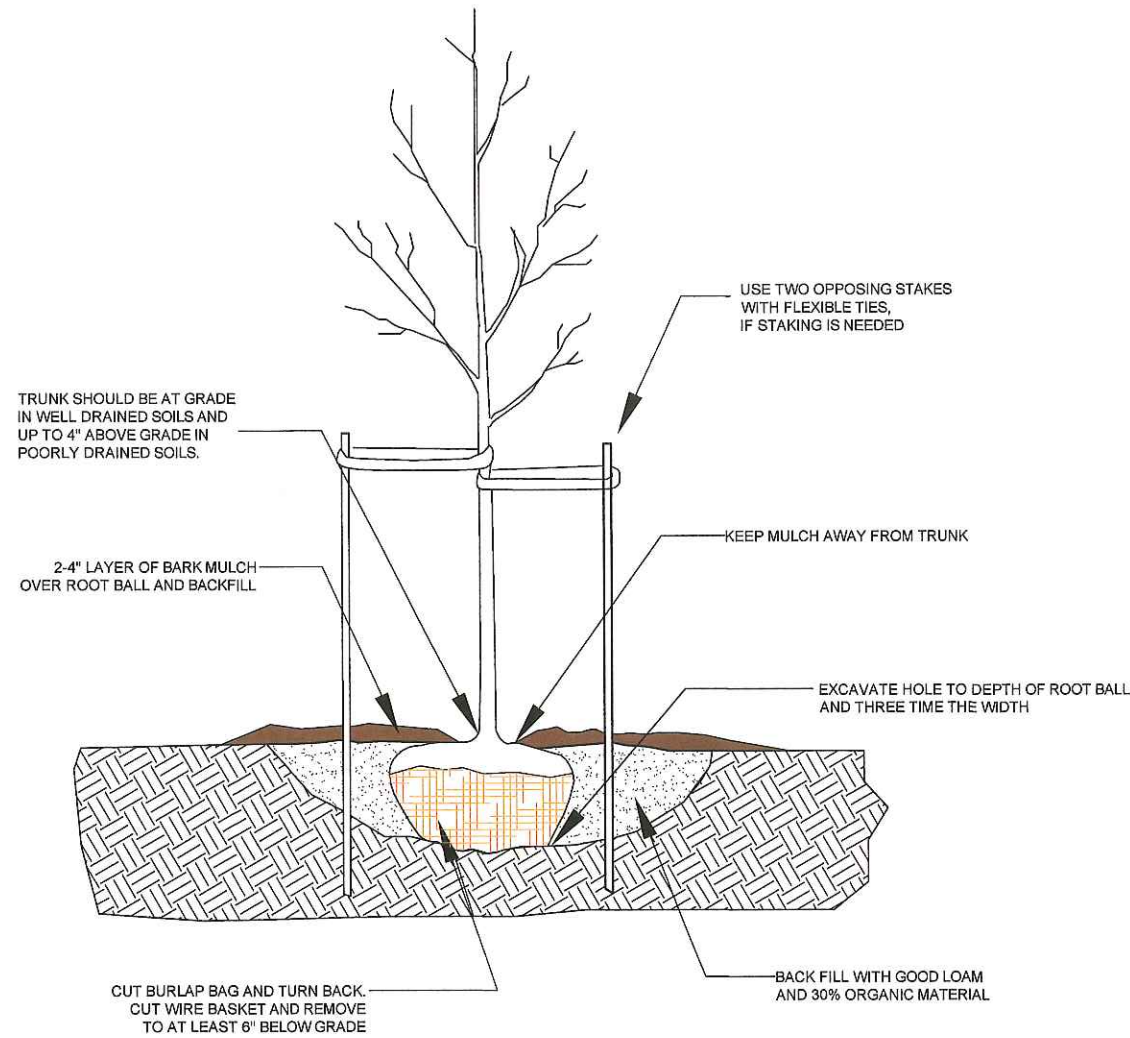

TREE PLANTING DETAIL

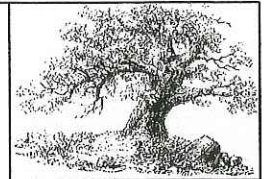

ANNE WELLINGTON
 Landscape Design & Construction

14 Olin Avenue
 Chester, Massachusetts, 01011
 617.872.1373
 anne@annewellington.com
 www.annewellington.com

CHESTNUT HILL MANOR
 BRIGHTON, MA

CHESTNUT HILL MANOR
 CONDOMINIUM ASSOCIATION
 185 & 189 CHESTNUT HILL AVE
 BRIGHTON, MA, 02135

LANDSCAPE DESIGN PLAN

PLANTING & LIGHTING PLAN

DETAILS ONE PLANTING DETAILS

DATE: MARCH 17, 2017
 REV. DATE:

PAGE 5 OF 6
 5
 6

EXISTING DOORWAY WALL-MOUNTED FIXTURE IS A TRADITIONAL SIX-SIDED BLACK WALL LAMP

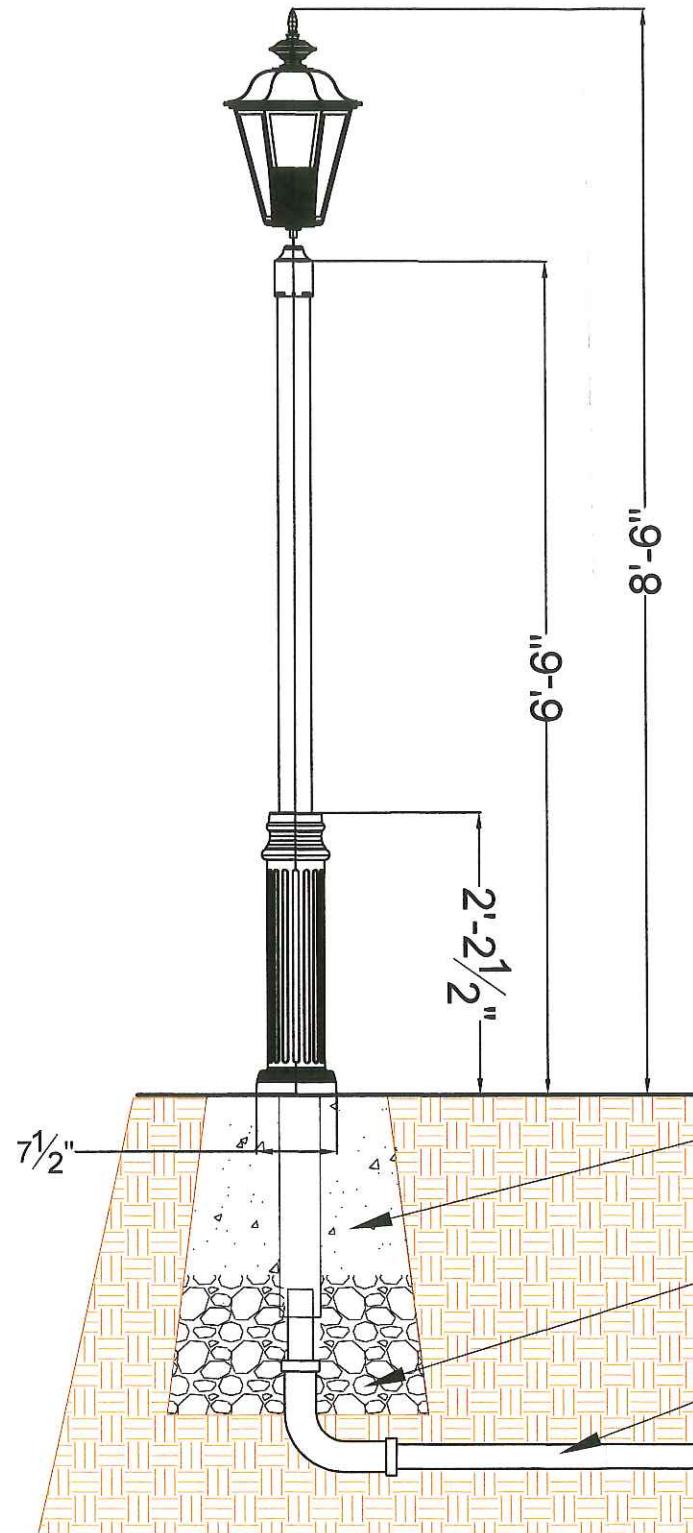

CENTER POST TOP FIXTURE: 6930
 Heritage Series, Six-sided Tapered Cage Construction.
 POST: 245PPF
 Features a 7 1/2" diameter fluted base with a straight smooth pole shaft.
 Available in both anchor bolt or direct burial configurations.
 Mode: 245P
 Shaft Type: Smooth 3" (P) (PF)

LIGHT SOURCE: 70HPS 120/MED?
 Ballast: 70HPS (High Pressure Sodium)
 Voltage: 120
 Socket Type: Single Medium Base Socket (MED)

OPTIONS: CTA/
 Lens: Clear Textured Acrylic (CTA)

FINISH: BK
 Assembly shall be powder coated to Black Smooth finish.
 Prior to coating, the assembly shall be chemically cleaned and etched in a 5-stage washing system which included alkaline cleaning, rinsing, phosphoric etching, reverse osmosis water rinsing, and non-chrome sealing to ensure corrosion resistance.

CONCRETE 16" MINIMUM
 COMPACTED GRAVEL BASE
 SCHEDULE 40 CONDUIT

LIGHTING DETAIL- INSTALLATION
 HERITAGE LIGHT ON FLUTED BASE AND SMOOTH SHAFT, DIRECT-BURIAL POLE

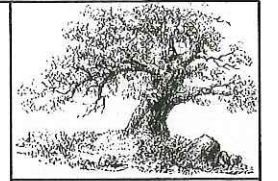

ANNE WELLINGTON
 Landscape Design & Construction
 14 Olin Avenue
 Chester, Massachusetts, 01011
 617.872.1373
 anne@annewellington.com
 www.annewellington.com

CHESTNUT HILL MANOR
 BRIGHTON, MA
 CHESTNUT HILL MANOR
 CONDOMINIUM ASSOCIATION
 185 & 189 CHESTNUT HILL AVE
 BRIGHTON, MA, 02135

LANDSCAPE
 DESIGN
 PLAN
 PLANTING &
 LIGHTING PLAN

LIGHTING
 DETAILS

LIGHTING
 DETAILS

CHESTNUT HILL MANOR

185 & 189 Chestnut Hill Avenue, Brighton, Massachusetts

March 23, 2017

Common Name: Vinca, Periwinkle, Myrtle

Botanical Name: *Vinca minor*

Habit: Evergreen Ground Cover

Height: 6-12"

Width: 24"

Color: Dark green foliage, bluish-lavender flowers

Season of Bloom: Early Spring

Hardiness: Zone 4-8

Other Features: Spreading ground cover, hardy



ANNE WELLINGTON
LANDSCAPES



CHESTNUT HILL MANOR

185 & 189 Chestnut Hill Avenue, Brighton, Massachusetts

Common Name: Celestial Rutgers' Hybrid Dogwood

Botanical Name: *Cornus 'Celestial'*

Habit: Deciduous Ornamental Tree

Height: 20'

Width: 20'

Color: White to Blush

Season of Bloom: Late Spring, Summer

Hardiness: Zone 5

Other Features: Long lasting flowers, disease resistant

March 23, 2017

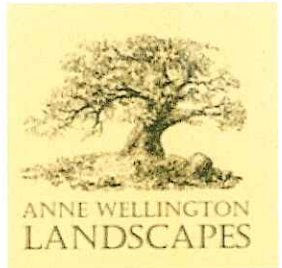

CHESTNUT HILL MANOR

185 & 189 Chestnut Hill Avenue, Brighton, Massachusetts

March 23, 2017

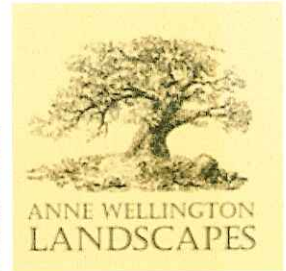

Common Name: Nikko Blue Hydrangea

Botanical Name: *Hydrangea macrophylla* 'Nikko Blue'

Habit: Deciduous

Height: 6'

Width: 6'

Color: Blue to Pink depending on soil pH

Season of Bloom: Summer into Fall

Hardiness: Zone 3-8

Other Features: Flower heads persist into winter season



CHESTNUT HILL MANOR

185 & 189 Chestnut Hill Avenue, Brighton, Massachusetts

March 23, 2017

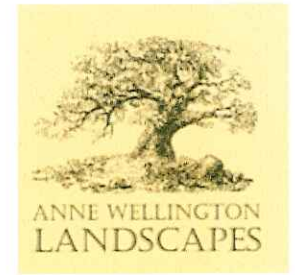

Common Name: Hicks Yew
Botanical Name: *Taxus 'Hicksii'*
Habit: Evergreen
Height: 3-4'
Width: 3-4'
Color: N/A
Season of Bloom: N/A
Hardiness: Zone 4-9
Other Features: Easily clipped



CHESTNUT HILL MANOR

185 & 189 Chestnut Hill Avenue, Brighton, Massachusetts

Common Name: Siebold Hosta

Botanical Name: *Hosta sieboldiana* 'Elegans'

Habit: Herbaceous perennial

Height: 24-36"

Width: 24-36"

Color: Large blue leaves, flowers –lavender white bells along stems

Season of Bloom: Summer

Hardiness: Zone 4-8

Other Features: Foliage interest throughout the growing season

March 23, 2017

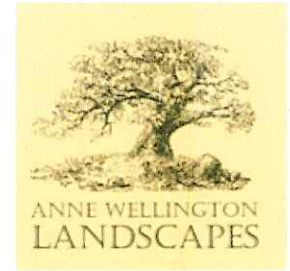

CHESTNUT HILL MANOR

185 & 189 Chestnut Hill Avenue, Brighton, Massachusetts

March 23, 2017

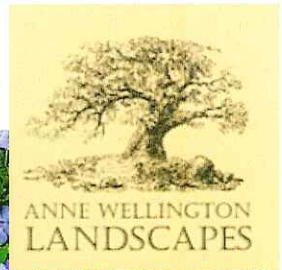

Common Name: Vinca, Periwinkle, Myrtle

Botanical Name: *Vinca minor*

Habit: Evergreen Ground Cover

Height: 6-12"

Width: 24"

Color: Dark green foliage, bluish-lavender flowers

Season of Bloom: Early Spring

Hardiness: Zone 4-8

Other Features: Spreading ground cover, hardy





Sternberg Lighting

ESTABLISHED 1923 / EMPLOYEE OWNED

GENESIS Product Configurator

Catalog Number: 6930/245PPF/70HPS120/MED/CTA/BK	Type:
--	-------

Customer Approval:

Conceptual assembly drawing, subject to Engineering verification by factory.

Signature _____

Date _____

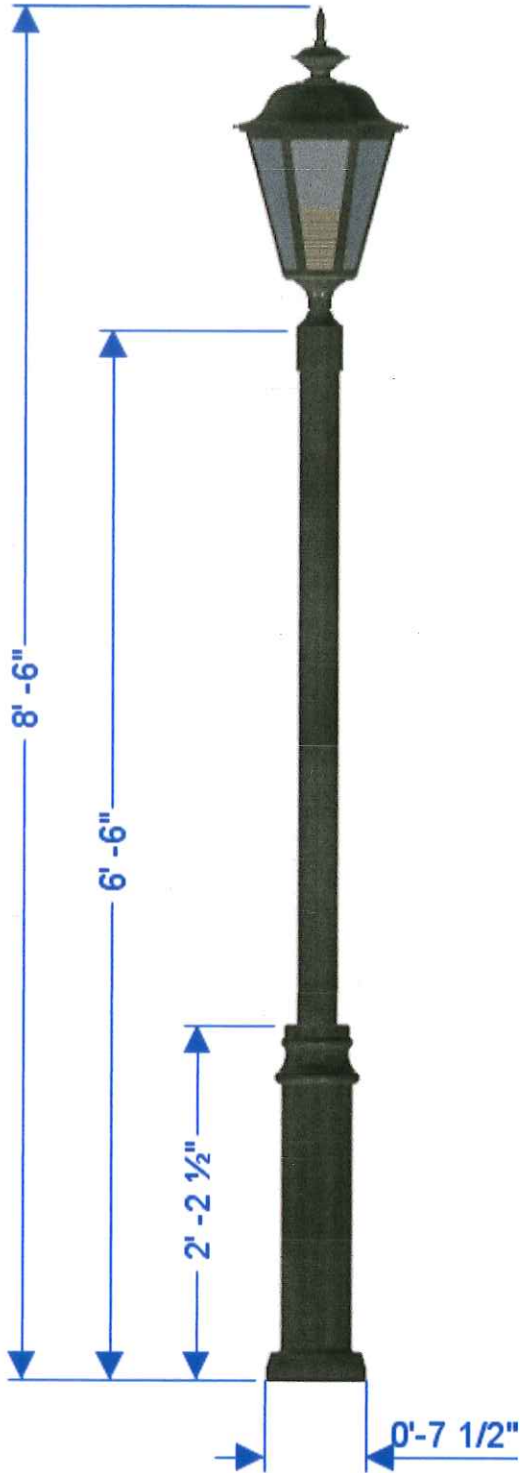

CENTER POST TOP FIXTURE: 6930

The 6900 Heritage series features a tapered, six-sided cage construction. The quiet elegance of this design has become a classic.

POST: 245PPF/

The 245P features a 7-1/2" diameter fluted base with a straight smooth pole shaft. It is available in both anchor bolt mounted or direct burial configurations.

Model: 245P
Shaft Type: Smooth Straight 3 in. (P) (PF)

LIGHT SOURCE: 70HPS120/MED/

Ballast: 70HPS
Voltage: 120
Socket Type: Single Medium Base Socket (MED)

OPTIONS: CTA/

Lens: Clear Textured Acrylic (CTA)

FINISH: BK

Assembly shall be powder coated to Black Smooth finish. Prior to coating, the assembly shall be chemically cleaned and etched in a 5-stage washing system which includes alkaline cleaning, rinsing, phosphoric etching, reverse osmosis water rinsing, and non-chrome sealing to ensure corrosion resistance.

Chestnut Hill Manor Condominiums
Aberdeen Architectural Conservation District
185 & 189 Chestnut Hill Avenue
Brighton, MA, 02135

3/17/2017

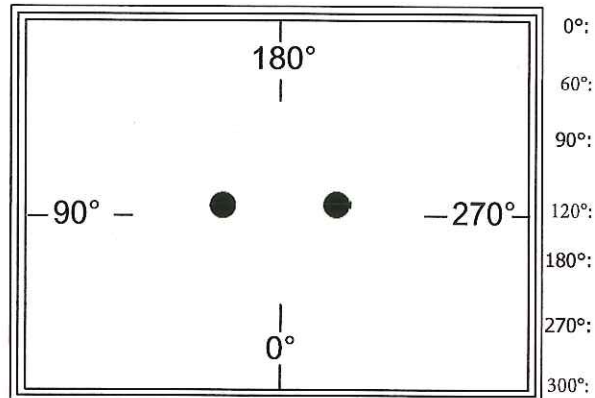

Bolt Info: (2) 3/8" x 12" Anchor Bolts, 6-5/8" Bolt Circle

Access Door Orientation: 0°
Street Side Orientation: 180°

Rev	Description	By	Date	Job Name: CHESTNUT HILL, MA			Drawing No. 14774
A				Job Location: CHESTNUT HILL, MA			
B				Drawn By: DSS	Drawn Date: 3/8/17	Checked By:	Checked Date:
C							
D							
E							