



1936 Beacon St
Brighton MA 02135

Exterior Sign Package

FASTSIGNS
More than fast. More than signs.™

FASTSIGNS
922 Main Street
Waltham, MA 02451
Tel: 781-642-7446
Fax: 781-642-7171

CUSTOMER:
Amelia's Taqueria

PROJECT :
Exterior Sign Package

DATE:

SCALE:
As Noted

DRAWN BY:

WORK ORDER:

DRAWING NO:
Version 1

FILE:

REVISIONS:

Fabricated 080 Gauge Steel Lettering - 5" Deep Painted White - Externally Illuminated with Gooseneck Lighting
 Overall Size is 11.5" x 105.1" - Letter height is 8.5"

AMELIA'S TAQUERIA

FASTSIGNS
 More than fast. More than signs.™

FASTSIGNS
 922 Main Street
 Waltham, MA 02451
 Tel: 781-642-7446
 Fax: 781-642-7171

CUSTOMER:
 Amelia's Taqueria

PROJECT :
 Exterior Sign Package

DATE:

SCALE:
 As Noted

DRAWN BY:

WORK ORDER:

DRAWING NO:
 Version 1

FILE:

REVISIONS:

This artwork is Copyright © 2013
 FastSigns 401. Use of this artwork by
 any party other than FastSigns 401 for
 any purpose whatever is prohibited
 without a signed release from
 FastSigns 401.

Fabrication of Lettering

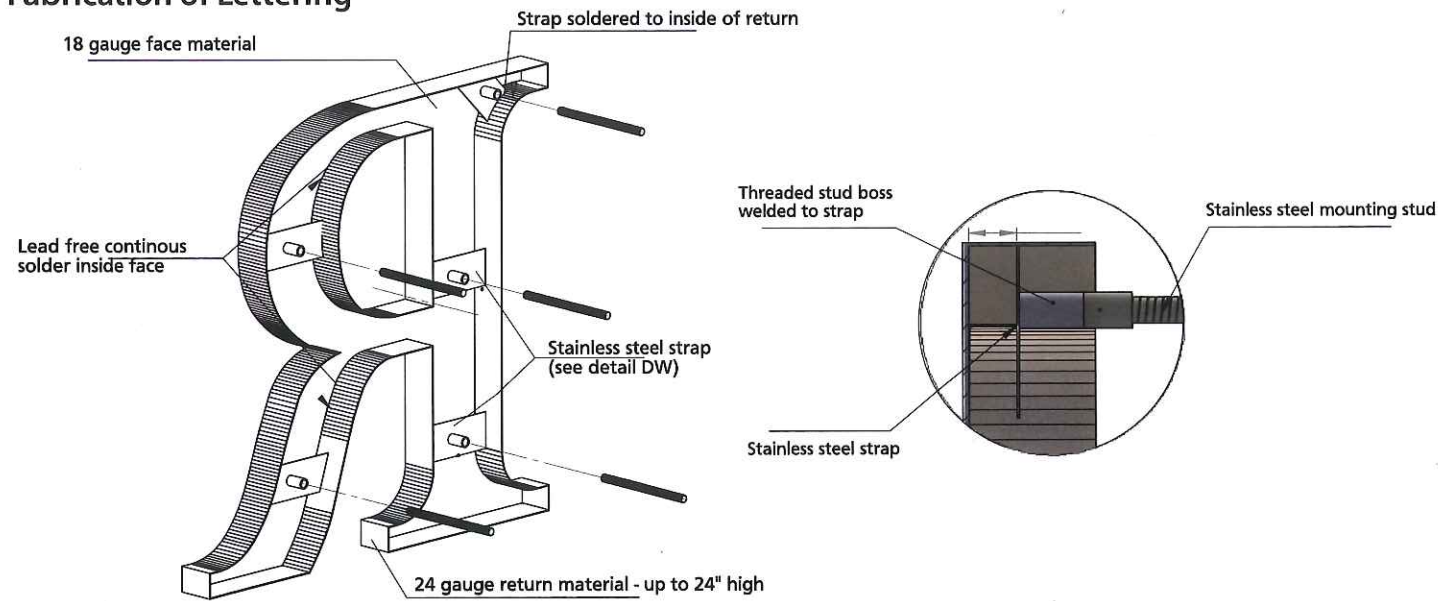

Gooseneck Lighting Specs

Angle Shades

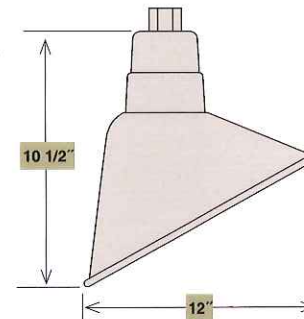

ITEM #	WIDTH	LAMPS	WIRE	FINISH
RAS12-SB	12"	Med. 200W A21	100'	Satin Black

Back Plate

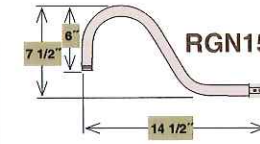

ITEM #	ID	LENGTH	FINISH
RGN15-SB	3/4"	14 1/2"	Satin Black

Overall Size is 11" x 220" - 040 Aluminum Panel mounted Directly to Facade with stainless steel self tapping screws and cover the screws with beauty caps. (The lettering Amelia's Taqueria will not be printed - just for Show)



1 Proposed Elevation
 Scale: 1/4" = 1'

S1
 SHEET 1 OF 4

Digital Rendering - Exterior Facade



Scale: NTS

FASTSIGNS
More than fast. More than signs.™

FASTSIGNS
922 Main Street
Waltham, MA 02451
Tel: 781-642-7446
Fax: 781-642-7171

CUSTOMER:
Amelia's Taqueria

PROJECT :
Exterior Sign Package

DATE:

SCALE:
As Noted

DRAWN BY:

WORK ORDER:

DRAWING NO:
Version 1

FILE:

REVISIONS:

This artwork is Copyright © 2013
FastSigns 401. Use of this artwork by
any party other than FastSigns 401 for
any purpose whatever is prohibited
without a signed release from
FastSigns 401.

S2
SHEET 2 OF 4

Double Faced Exterior Blade Sign - 1" Deep Hollow Aluminum Box with Painted edges and Vinyl Lettering for the face

Overall Size is 30" x 30"



Side View of of Box



Sign Bracket with External Spot Lighting

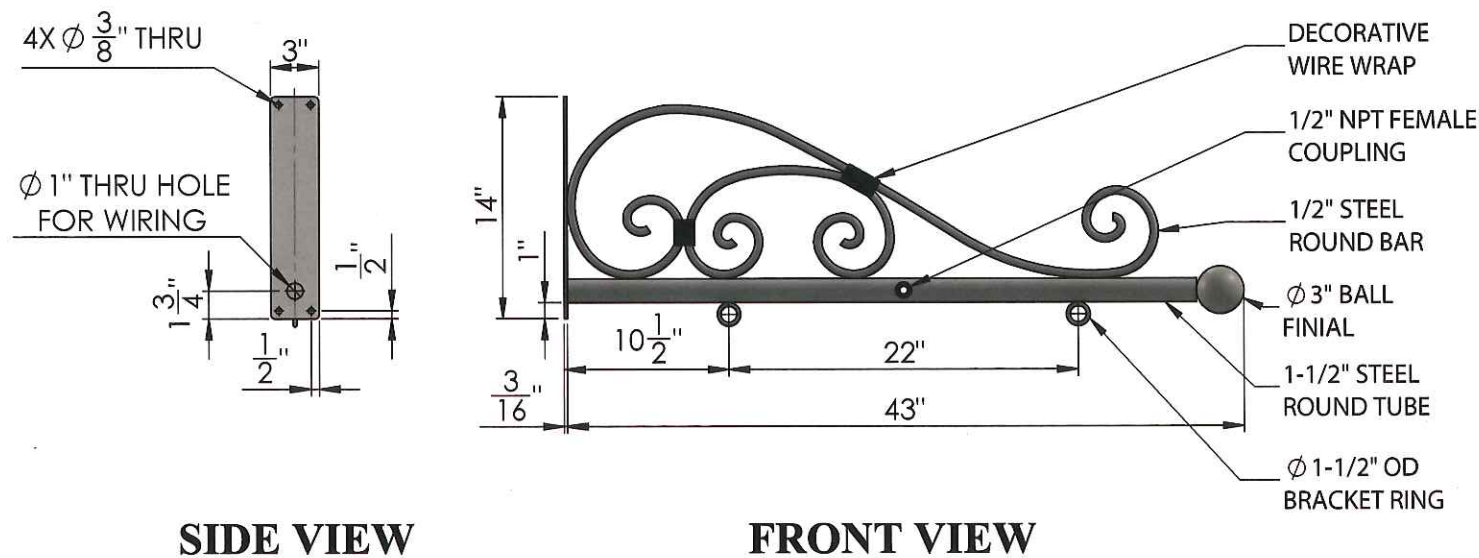

BRACKET WEIGHT: 13.3-LBS

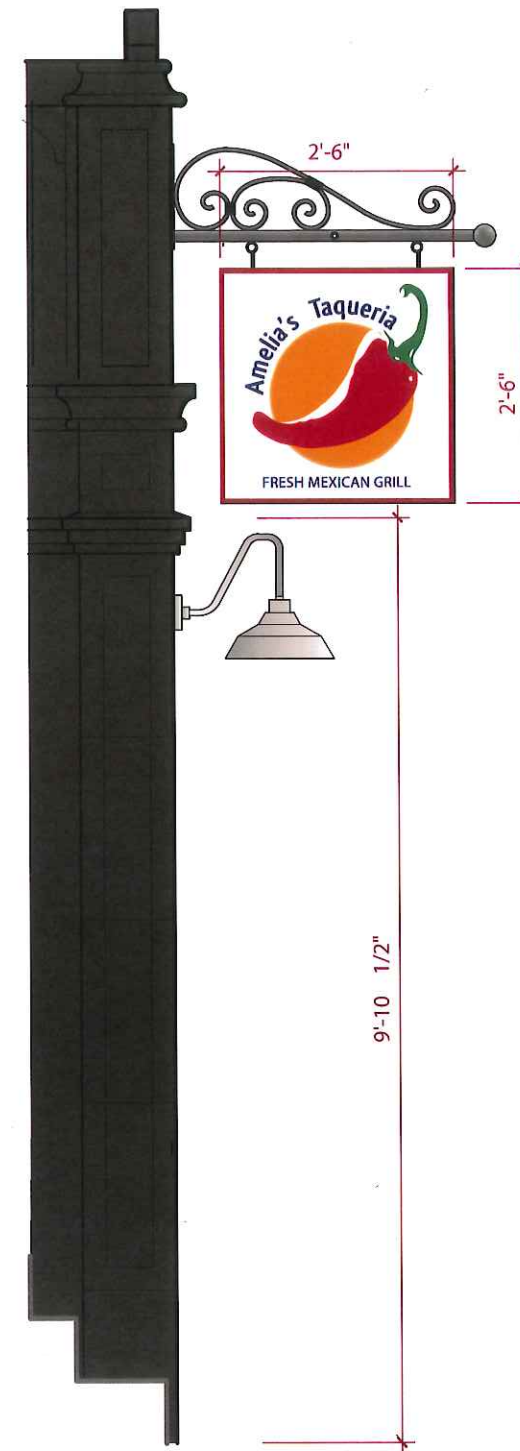

1 Proposed Elevation Sections
Scale: 1/2" = 1'-0"

FASTSIGNS
More than fast. More than signs.™

FASTSIGNS
922 Main Street
Waltham, MA 02451
Tel: 781-642-7446
Fax: 781-642-7171

CUSTOMER:
Amelia's Taqueria

PROJECT :
Exterior Sign Package

DATE:

SCALE:
As Noted

DRAWN BY:

WORK ORDER:

DRAWING NO:
Version 1

FILE:

REVISIONS:

This artwork is Copyright © 2013 FastSigns 401. Use of this artwork by any party other than FastSigns 401 for any purpose whatever is prohibited without a signed release from FastSigns 401.

S3
SHEET 3 OF 4

Digital Rendering - Exterior Facade



Scale: NTS

FASTSIGNS
More than fast. More than signs.™

FASTSIGNS
922 Main Street
Waltham, MA 02451
Tel: 781-642-7446
Fax: 781-642-7171

CUSTOMER:
Amelia's Taqueria

PROJECT :
Exterior Sign Package

DATE:

SCALE:
As Noted

DRAWN BY:

WORK ORDER:

DRAWING NO:
Version 1

FILE:

REVISIONS:

This artwork is Copyright © 2013
FastSigns 401. Use of this artwork by
any party other than FastSigns 401 for
any purpose whatever is prohibited
without a signed release from
FastSigns 401.

S4
SHEET 3 OF 4

Current Conditions



Neighboring Storefronts



FASTSIGNS
More than fast. More than signs.™

FASTSIGNS
922 Main Street
Waltham, MA 02451
Tel: 781-642-7446
Fax: 781-642-7171

CUSTOMER:
Amelia's Taqueria

PROJECT :
Exterior Sign Package

DATE:

SCALE:

DRAWN BY:

WORK ORDER:

DRAWING NO:
Version 1

FILE:

REVISIONS:

This artwork is Copyright © 2013
FastSigns 401. Use of this artwork by
any party other than FastSigns 401 for
any purpose whatever is prohibited
without a signed release from
FastSigns 401.

S5
SHEET 2 OF 4