

The Circle

January 12, 2017

Transportation and Off-Site Traffic Improvements

Presented by

National Development

Sherry Clancy, LEED AP

Charles Viola

Howard Stein Hudson

Robbie Burgess, P.E., PTOE

Hans Kuebler

Presented to

Aberdeen Architectural Conservation District Commission



HOWARD STEIN HUDSON

Engineers + Planners

Project Overview

Engineers + Planners

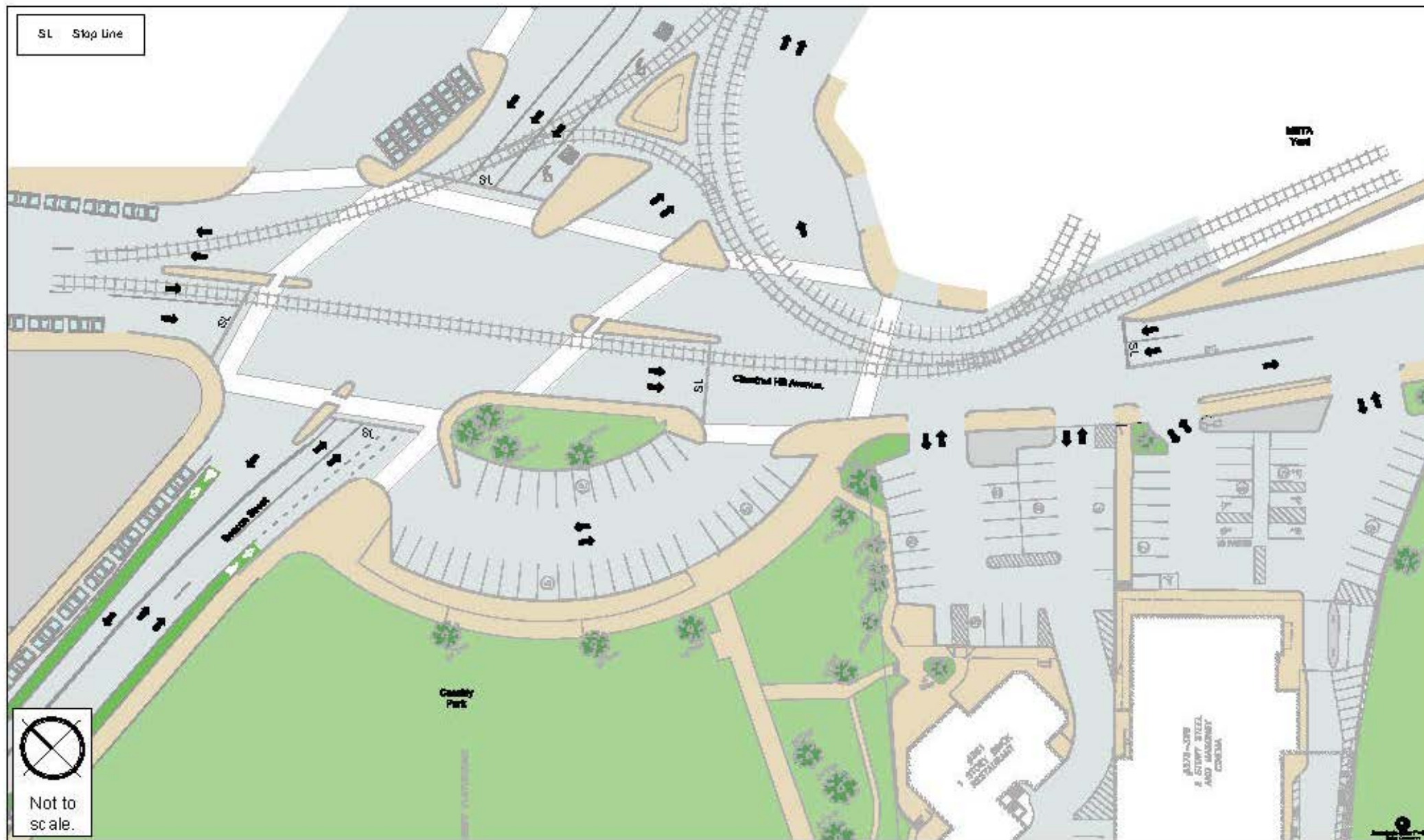

- **Cleveland Circle Improvements**
 - Upgrade Sidewalks and Wheelchair Ramps to Conform with ADA Guidelines
 - Replace Weathered Traffic Equipment
 - Optimize Signal Operations
 - Enhance Landscaping Features
- **Site Redevelopment**
 - 375-399 Chestnut Hill Ave.
 - 2.56-Acre Site (2 Buildings)
 - Mixed-Use Development
 - *Hotel*
 - *Retail*
 - *Residential*

Existing Conditions



Figure 1 - Near-side Pedestrian Signal Post, Base, Foundation and Head to be Replaced (Typ)



Figure 2 - Double Lamp to be Retained or Reset (Typ), Signal Post and Head to be Replaced (Typ), Mast Arm and Signal Heads to be Replaced (Typ)



Figure 3- Single Lamps to be Retained or Relocated (Typ), Landscaping to be Renewed

Existing Conditions



Figure 4 - Park-Side Pendant Light to be Relocated or Retained (Typ), Grass to be Retained, Control Cabinet to be Retained

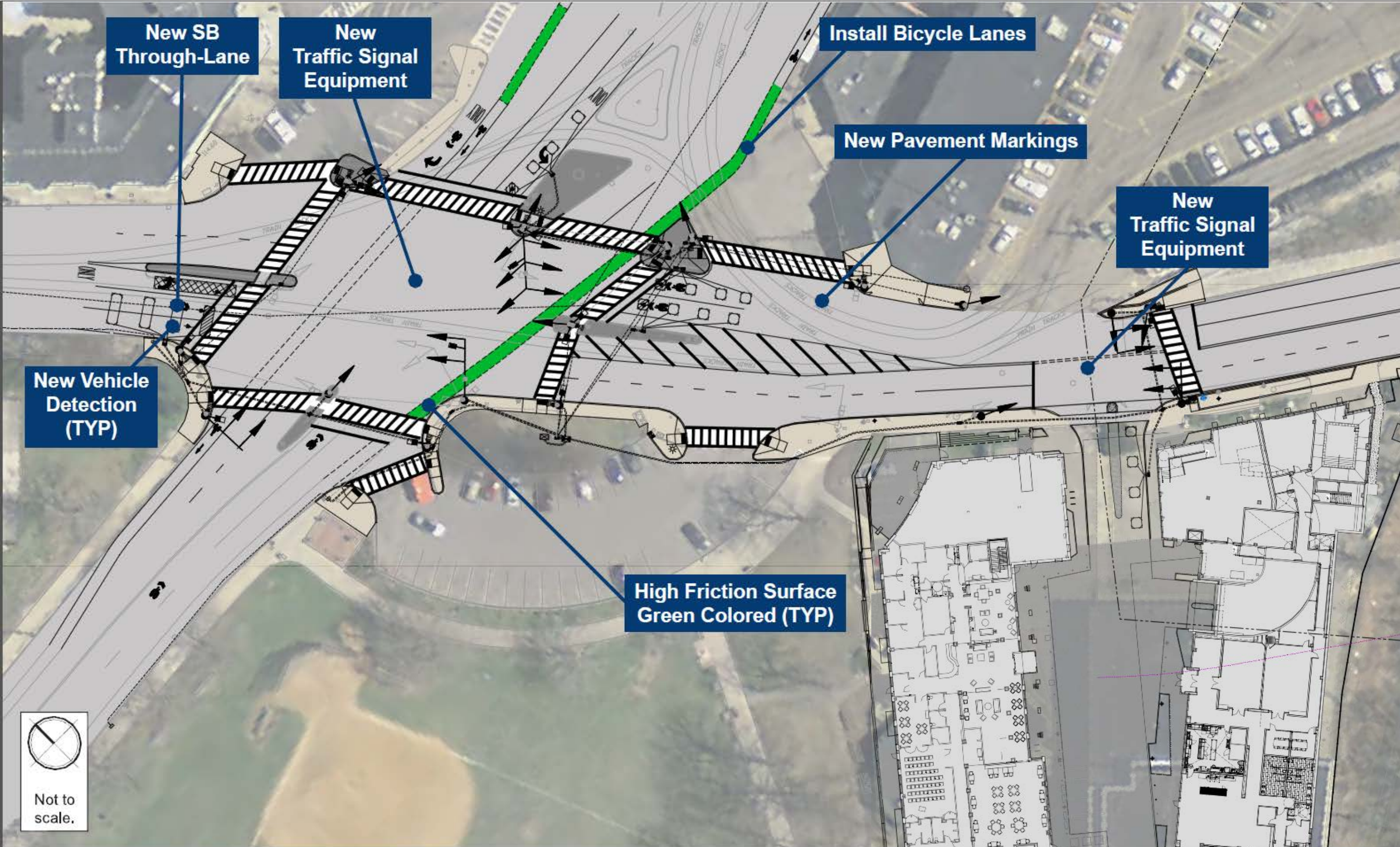

Figure 5 - Traffic Cabinet to be Retained



Figure 6 - Control Cabinet (left) to be Replaced in Kind on Existing Foundation, Battery Backup (right) to be Retained

Off-Site Traffic Scope of Work



Off-Site Scope of Work

Engineers + Planners

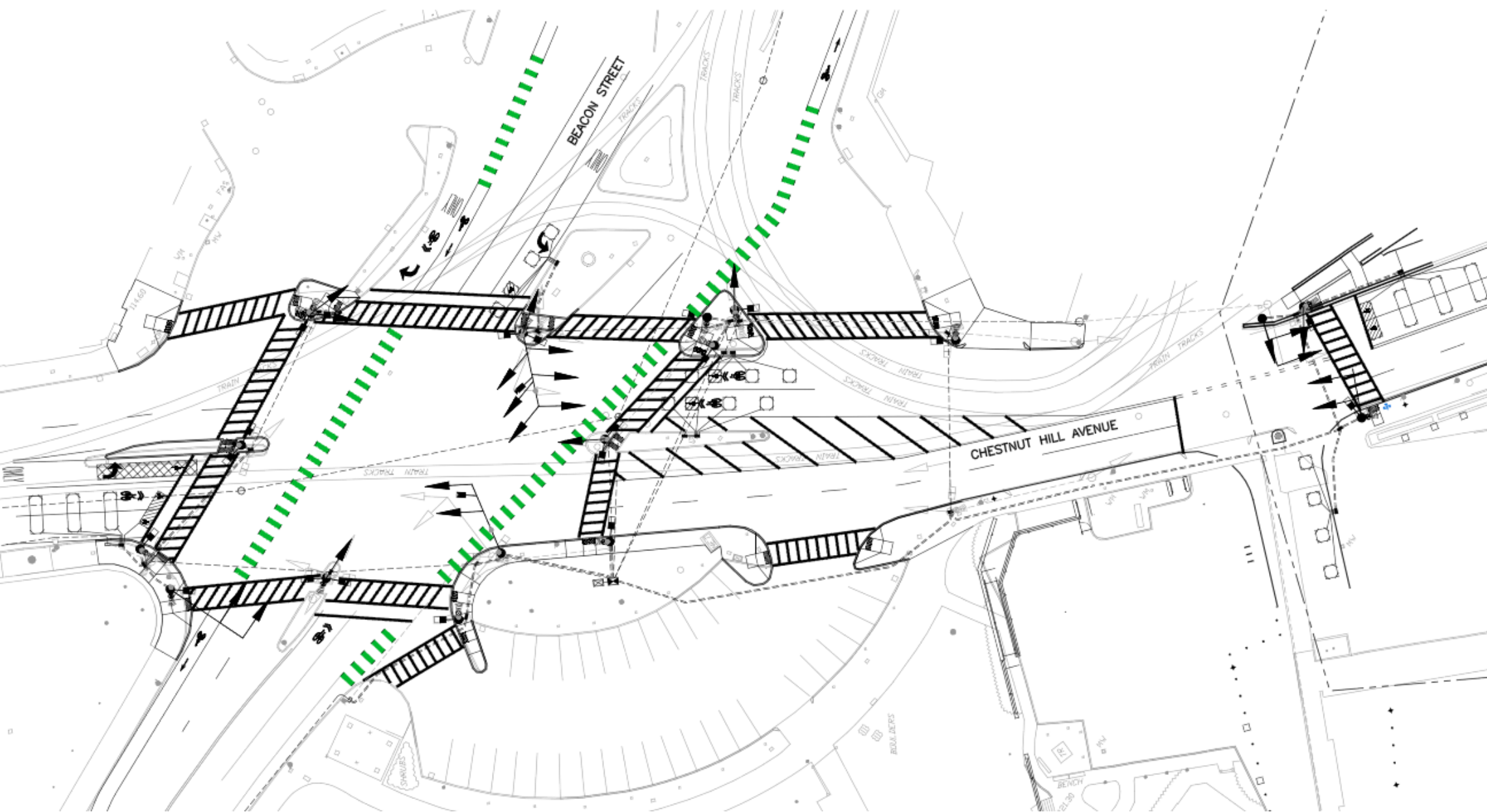

■ Signals

- All New Signal Equipment
- *New Pedestrian Crossing at Project Site*

■ Pavement Markings

- Re-Stripe Markings
- Add Pedestrian Crossing

■ Construction

- ADA Ramps
- Reconstruct Sidewalks
- Improve Landscaping
- Relocate Existing Street Lighting

Proposed Equipment: Traffic Signals

MassDOT Overhead Signal Structure & Foundation Standard Details

BTD Standard Traffic Signal Post

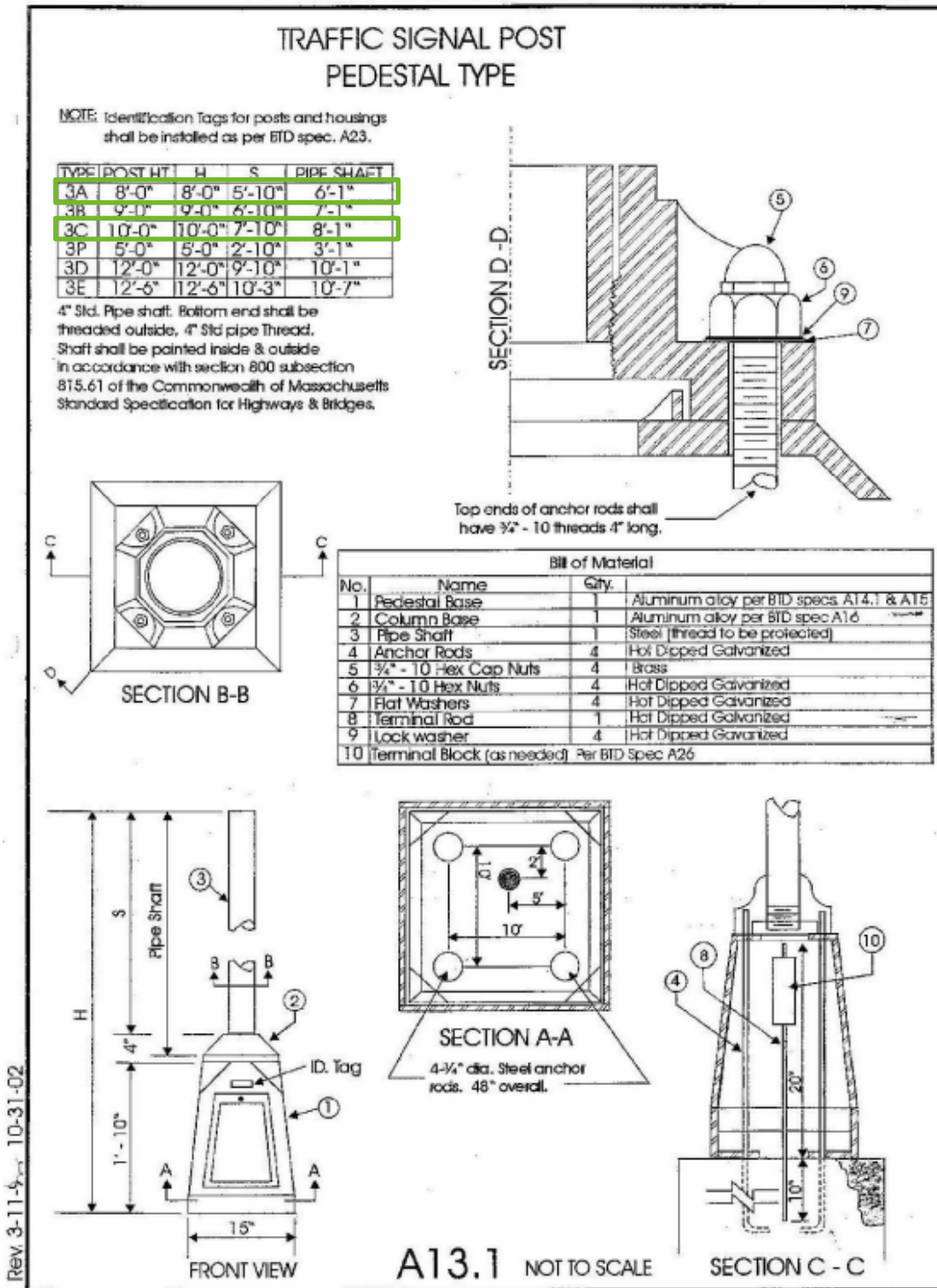
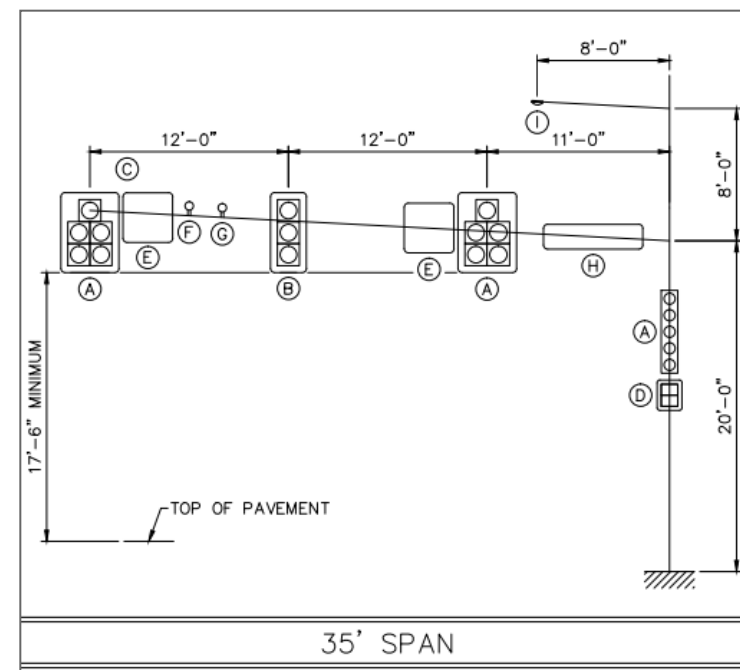
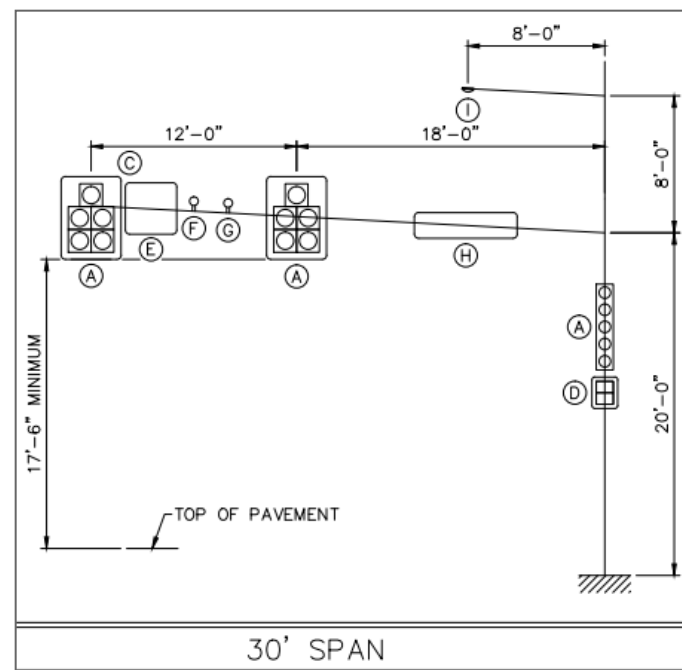
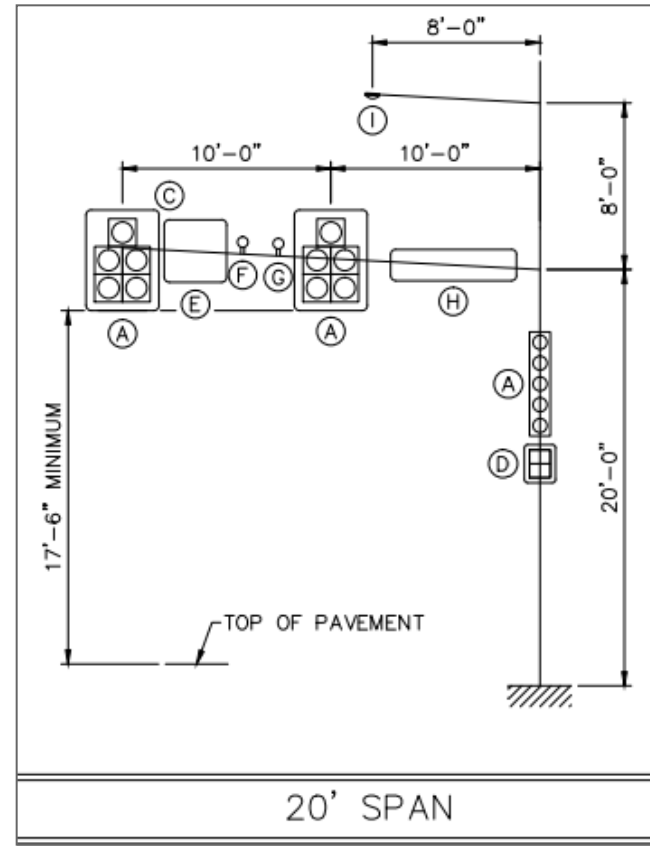
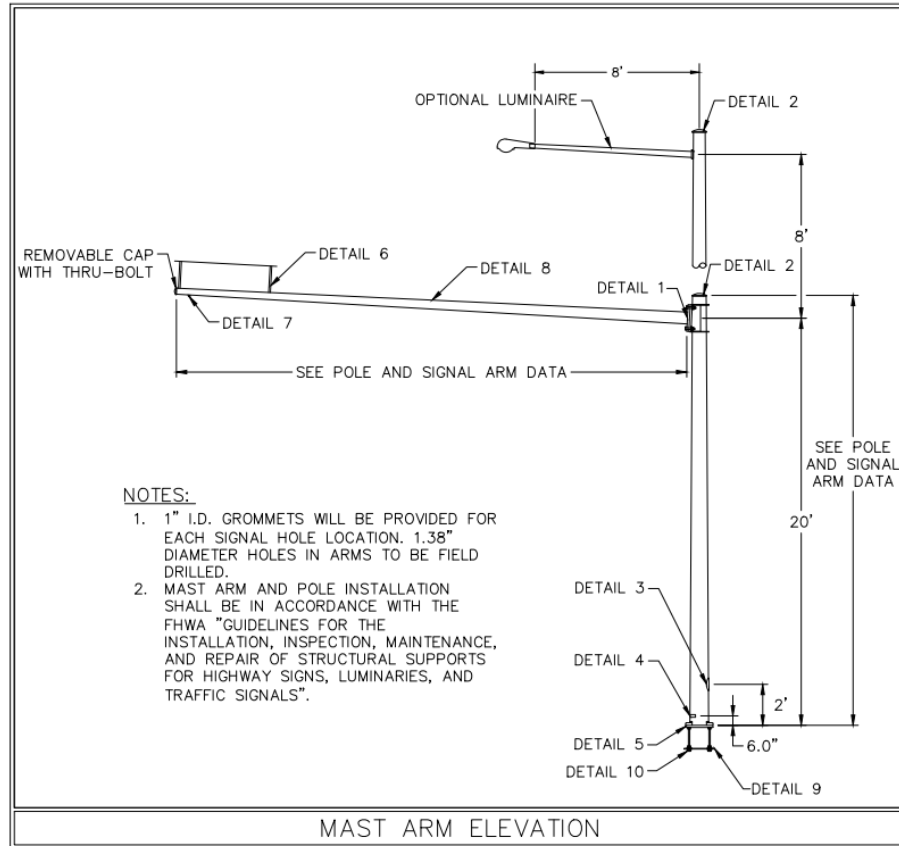

Proposed Equipment: Wheelchair Ramp Detectable Warning Panel

Engineers + Planners

Existing



Proposed



Dark Gray - Federal Color No. 36118

ADA PROWAG:

■ R 304.1.3 Contrast

- *Detectable warning surfaces shall contrast visually with adjacent gutter, street or highway, or walkway surfaces, either light-on-dark or dark-on-light.*

Landscape Improvements at Cleveland Circle

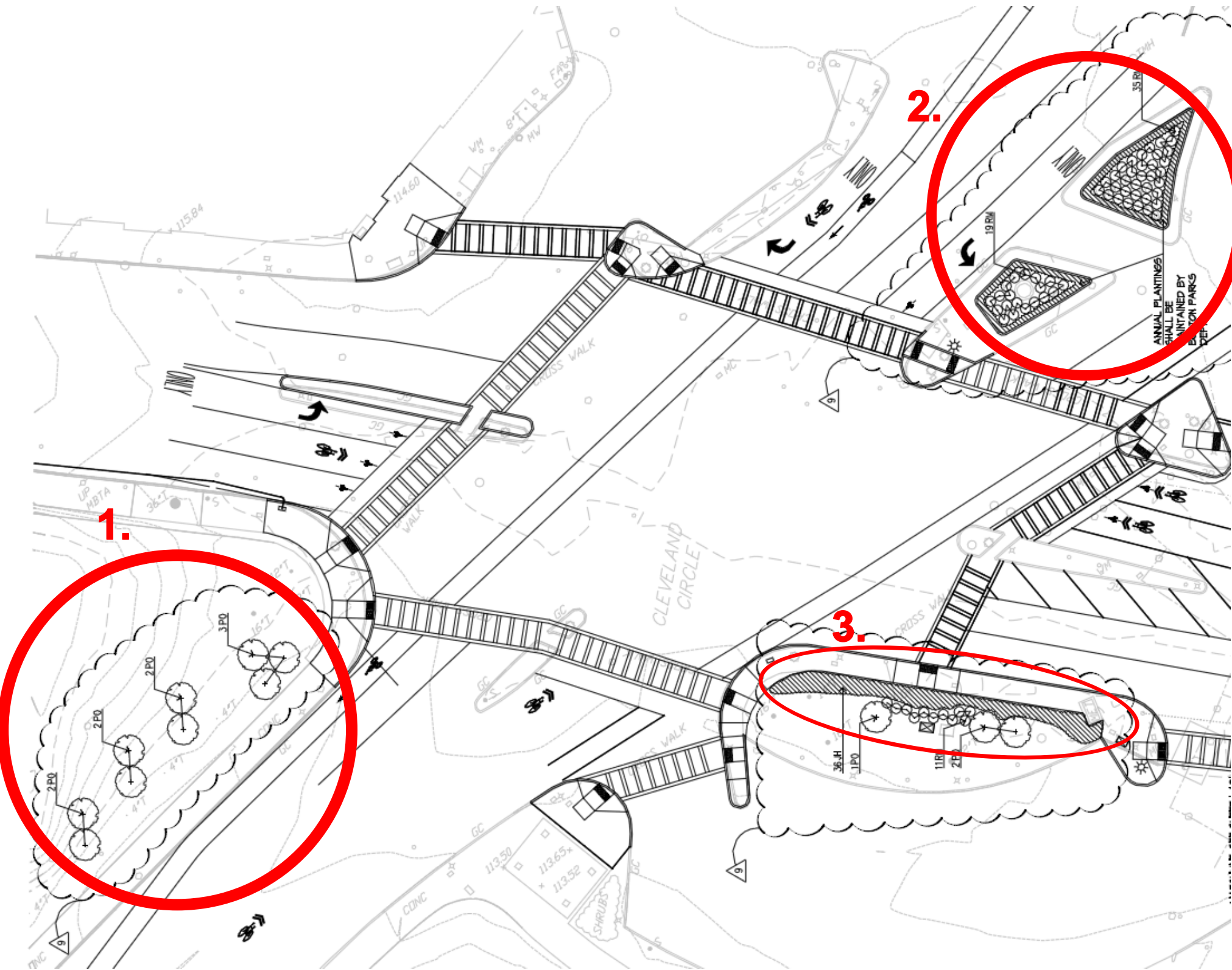

1. Deciduous Trees
2. Groundcover/Perennials and Shrubs
3. Groundcover/Perennials, Shrubs and Deciduous Trees

■ Design

- BTD
 - *Current: 100% Plans Submitted*
 - *Upcoming: PS&E*
- PIC
 - *Approved: Curb, Sidewalk and Wheelchair Ramp Improvements*
- MWRA
 - *Approved: Proposed Equipment Locations in Relation to MWRA Water and Sewer*
- MAAB
 - *Approved: Wheelchair Ramp Variance of MBTA Reservoir T Station Ramp at Chestnut Hill Ave*
- MBTA
 - *Approved: Proposed Equipment Locations in Relation to MBTA Owned Equipment*

■ Construction

- Current
 - *Building Construction Underway*
 - *Off-Site Test Pits and Underground Conduit Investigation Complete*
 - *Off-Site Improvement Construction Underway*

Questions?

